

PARÉ

INNOV +
CEILING AND WALL SYSTEMS



www.pareindia.com



About us

PARÉ Innovations is a leading player in the building material segment, specializing in top-notch surfaces for ceilings, walls and facade systems.

At PARÉ, we take immense pride in being at the forefront of innovation, introducing groundbreaking surfaces that have never been seen before in India. With our commercial base in Mumbai and our state-of-the-art manufacturing facility located near Vapi, Gujarat,

PARÉ is strategically positioned to serve the needs of our valued customers. Our founders have deep roots in the building material industry, which has propelled us to become pioneers in the Innovative Products revolution.

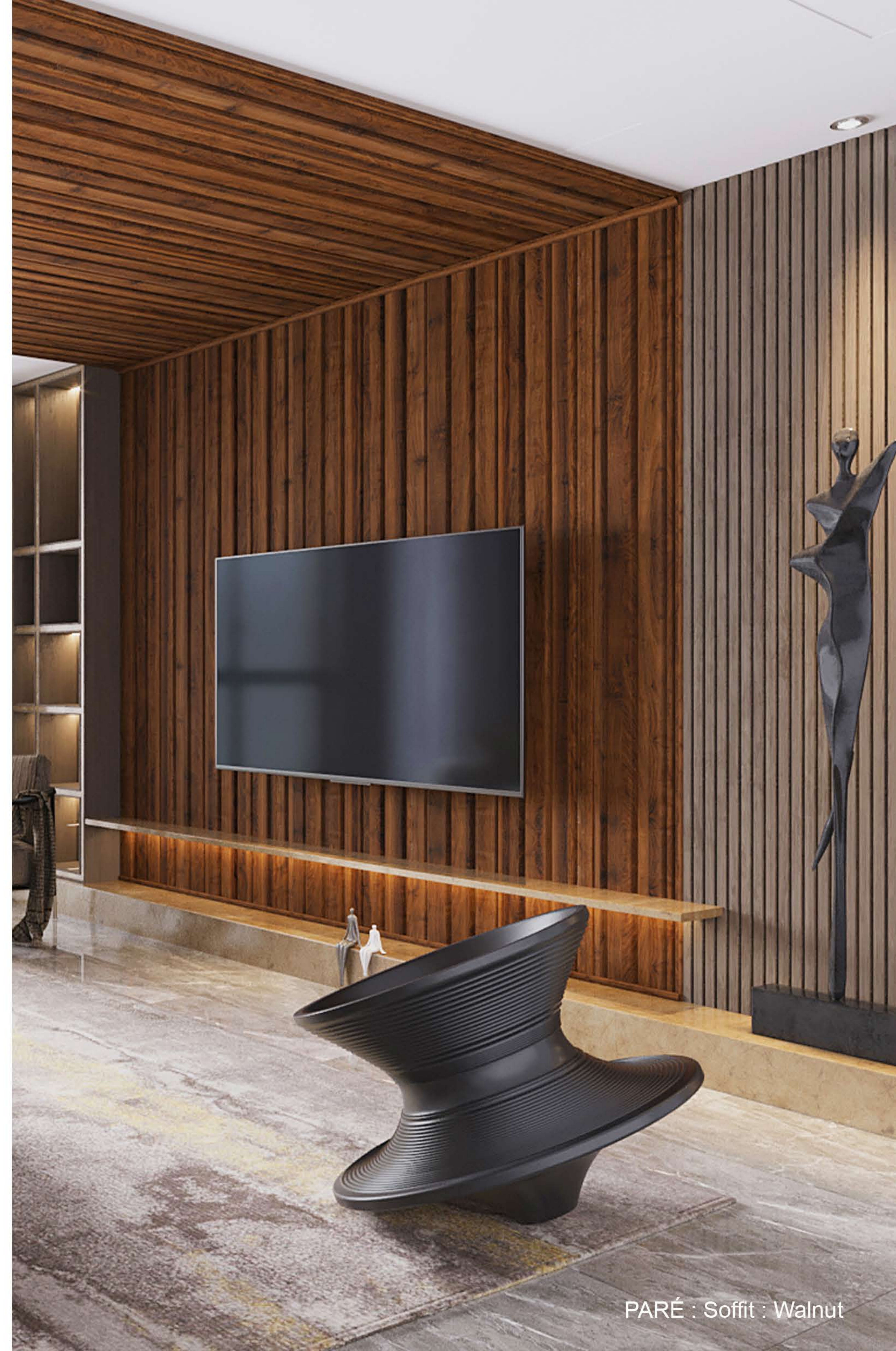



Manufacturing

PARÉ Innovations prides itself on its state-of-the-art manufacturing unit, which utilizes advanced European manufacturing technology to manufacture products of superior quality. It has launched quite a few products while being the first manufacturer in India for most of them.

PARÉ Innovations has been a pioneer in introducing many new products to the Indian market. PARÉ Innovations commitment to quality and innovation has helped it become a leading player in various industries.

TONGUE & GROOVE INTERLOCKING

PARÉ Innovation's innovative tongue and groove technology seamlessly interlocks panels, eliminating unsightly gaps and visible joints for a stunning, joint-free aesthetic. This intuitive system facilitates quick and efficient installation, ensuring rapid transformation of your space without compromising on flawless finishes.



FEATURES



LIGHT WEIGHT



FIRE RETARDANT



LEAD FREE



EASY TO INSTALL



WATERPROOF



ANTI BACTERIAL



NO VOC



10 YEAR WARRANTY



UNIQUE
INTERLOCKING



IMPACT RESISTANCE



TERMITE PROOF



SEAMLESS LOOK



RECYCLABLE



MAINTENANCE FREE



REAL WOOD LOOK



NO PLY REQUIRED

INNOV+

Discover the World of INNOV+, where innovative interior design meets convenience and style.

Our products feature a unique tongue and groove interlocking system, ensuring easy installation and a seamless look. With a wide range of shades available across all our product lines, you have the freedom to create personalized spaces that reflect your unique taste and vision. Embrace the versatility of INNOV+ and bring your dream interiors to life, where form and function coalesce effortlessly.

SOFFIT

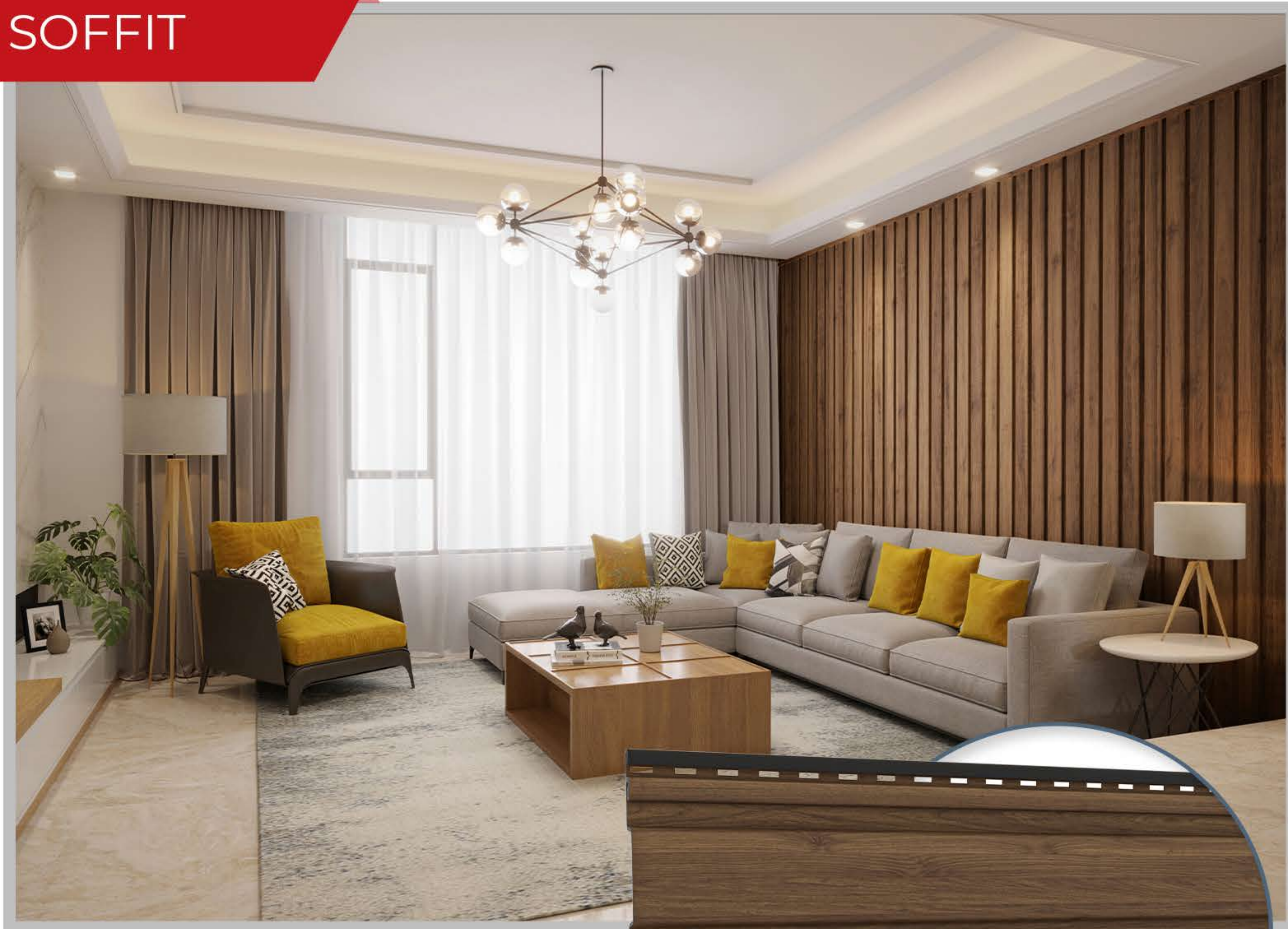

Usage: Internal ceilings and walls,
external ceilings
Shade available: 16 shades

DUO



Usage: Internal ceilings and walls,
external ceilings
Shade available: 12 shades

LOUVERS



Usage: Internal ceilings and walls,
external ceilings
Shade available: 13 shades

VERTICA

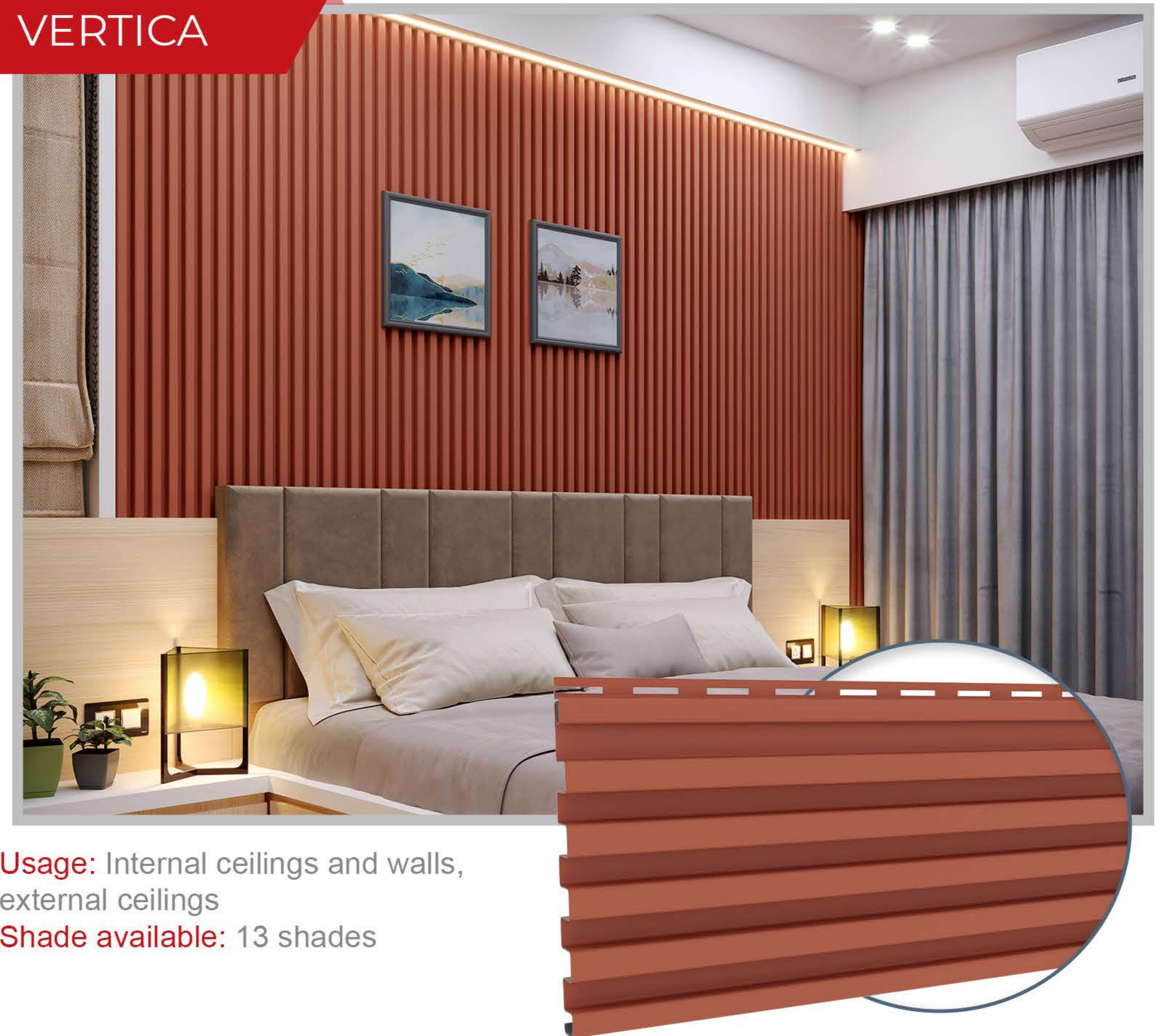

Usage: Internal ceilings and walls,
external ceilings
Shade available: 13 shades

SOFFIT PANELS



Soffit, real wood look and feel panels; made out of Polymer is the perfect blend of aesthetic appeal and convenience. Soffit Panels not only look like real wood but also replicate its feel. Using Tongue and Groove interlocking technology, this product is very easy to interlock and looks seamless post installation. Soffit is a convenient and economical alternative to wooden ceilings.

Soffit effortlessly harmonizes with diverse interior themes, becoming the quintessential choice for those seeking a perfect blend of style, utility and effortless aesthetics.

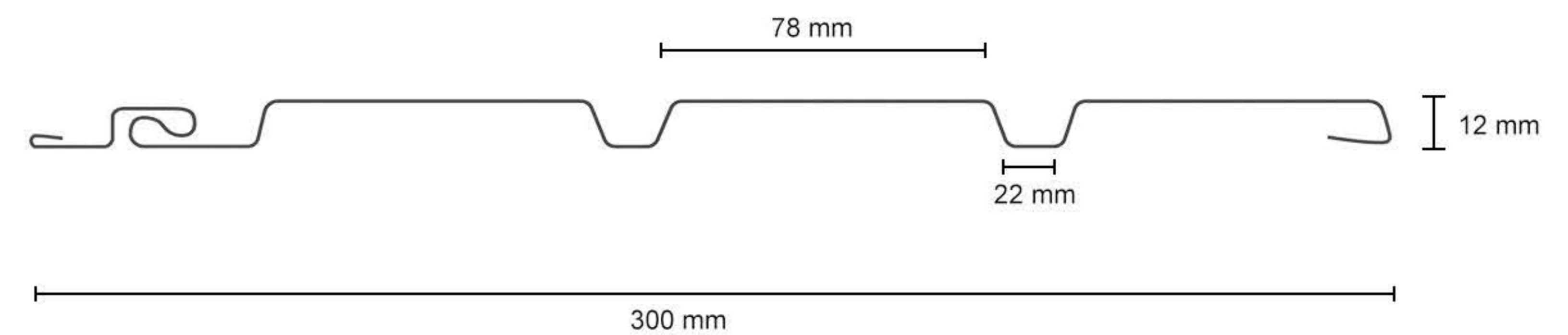

SHADES



PINE WOOD
(15)



MAPLE WOOD
(16)



BIRCH
(17)



GOLDEN OAK
(18)



WALNUT
(19)



WEATHERED GREY
(20)



SUPER WHITE
(21)



GRAPHITE
(25)



MAHOGANY
(28)



CHESTNUT
(29)



OAK WOOD OCRE
(30)



ROYAL NUT
(33)



ASHWOOD GREY
(34)



SPICED WALNUT
(36)



IMPERIAL NUT
(31)



ARTISAN OAK
(32)

**Product colour may vary from that shown in picture.

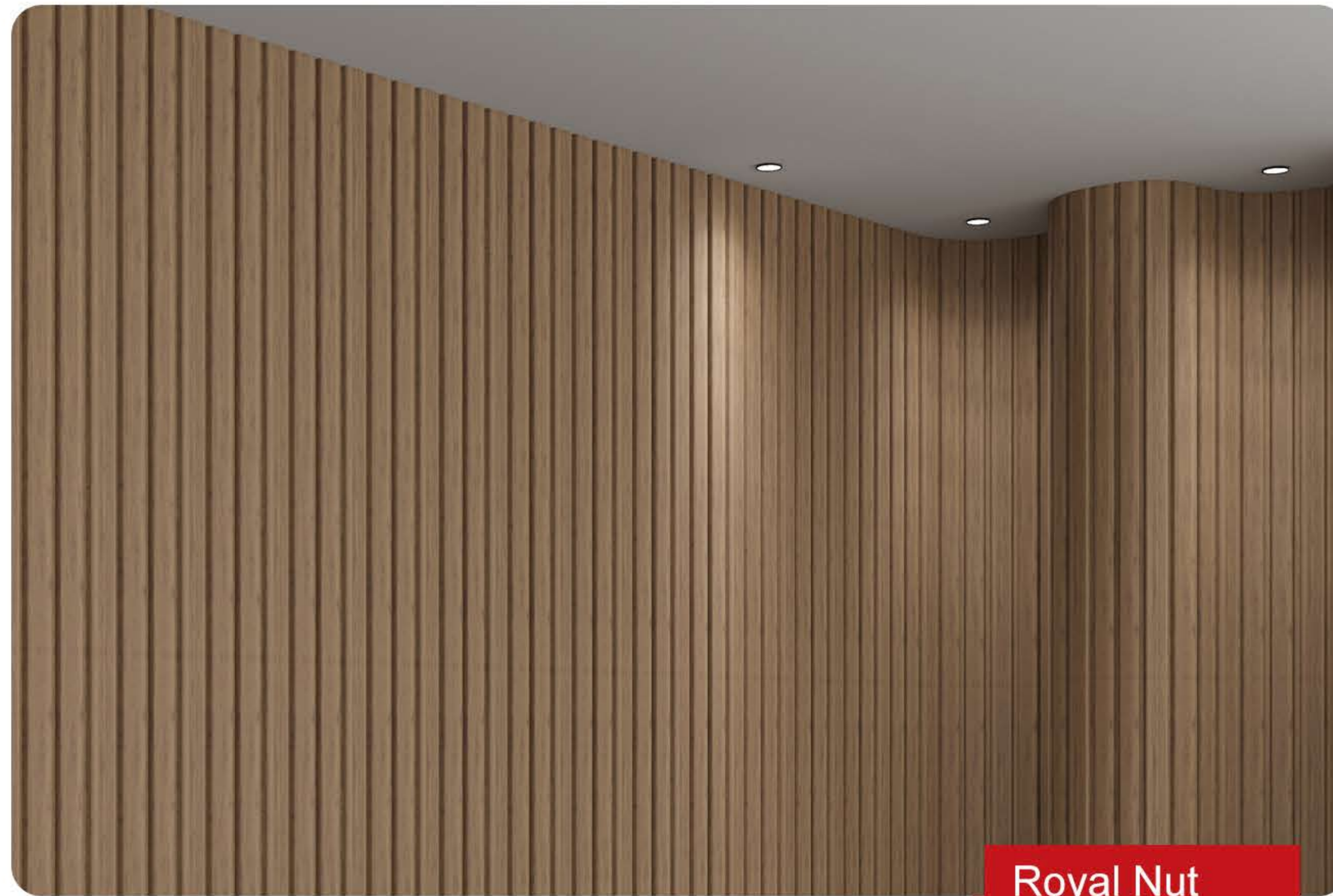

Soffit Panels are **flexible in nature** and thus, can be used in areas with curvature as well.



Soffit panels are **compatible with** a number of **different lightings** without letting it compromise the overall aesthetics.



Soffit Panels can be used in interior as well as **exterior ceilings** to give a real wood look.



Oakwood Ocre from Soffit **enriches spaces** with a timeless and earthy aesthetic, seamlessly merging elegance and nature.

PERFORATION

PARÉ offers **three types of perforation**; panels without perforation, panels with middle plank perforation and panels with three plank perforation. Panels with perforations are used for dispersing heat from one layer to another.

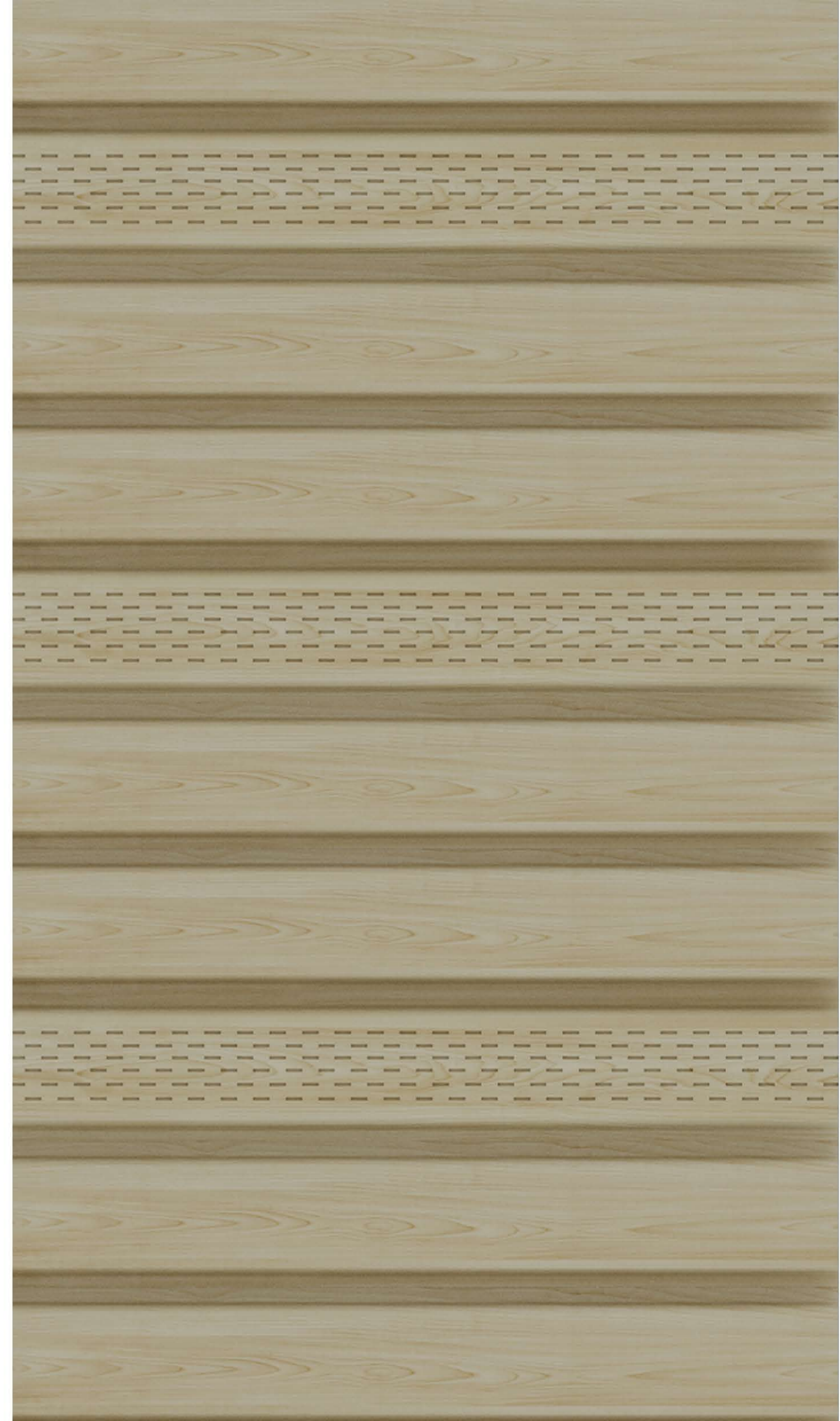
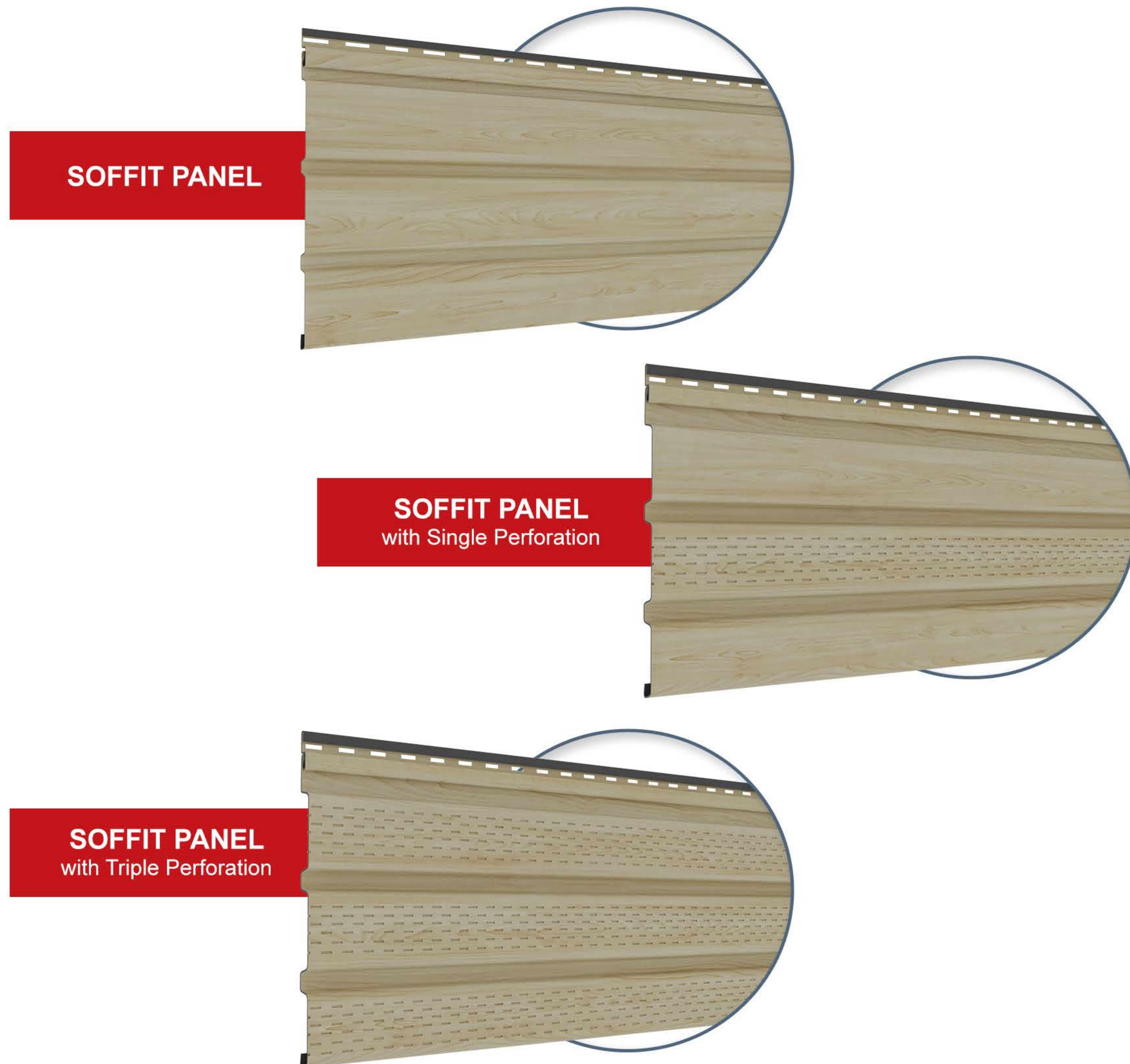

FEATURES



LIGHT WEIGHT



FIRE RETARDANT



MAINTENANCE FREE



NO VOC

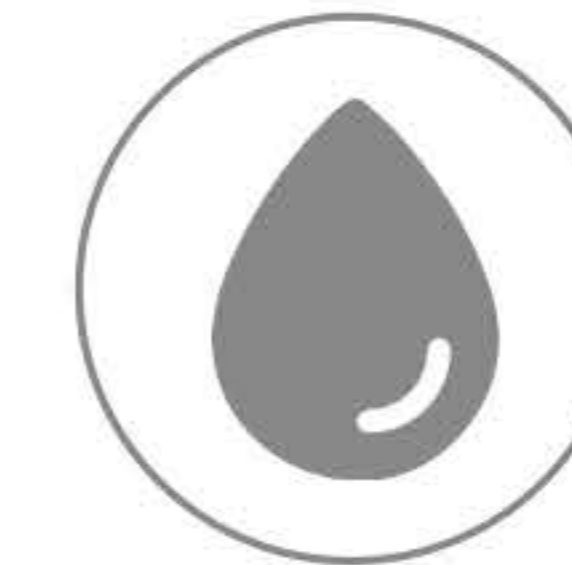

WATERPROOF



REAL WOOD LOOK



EASY TO INSTALL



ADVANCE INTERLOCKING



TERMITE PROOF

HEAT TRANSFER TECHNOLOGY

PARÉ Innovations unlocks the secrets of eternal allure with its revolutionary heat transfer technology. This European marvel infuses our panels with lifelike textures, capturing the exquisite essence of real wood in every intricate detail.

Imagine sun-kissed warmth gracing your fingertips, wood-grained elegance adorning your ceilings, and a space that breathes sophistication without effort. Our technology goes beyond mere replication; it imprints the very soul of wood, with every vein and knot whispering a tale of nature's artistry.

DUO

PANELS



Immerse yourself in nature's timeless elegance, effortlessly. PARÉ Duo Panels bridge the gap between artistry and engineering, bringing the warmth of real wood to your walls and ceilings, without the limitations. Crafted with meticulous detail, Duo Panels blur the lines between reality and illusion with their captivating textures and grains. Effortless installation thanks to our revolutionary interlocking technology, so you can revamp your space in a breeze. But Duo Panels are more than just stunning visuals.

They offer enduring beauty with exceptional rigidity and support, and a curated palette of shades to match your vision. Adapting seamlessly to any space, Duo Panels elevate your ambiance with timeless elegance, all while being sustainably crafted and backed by our industry-leading warranty.

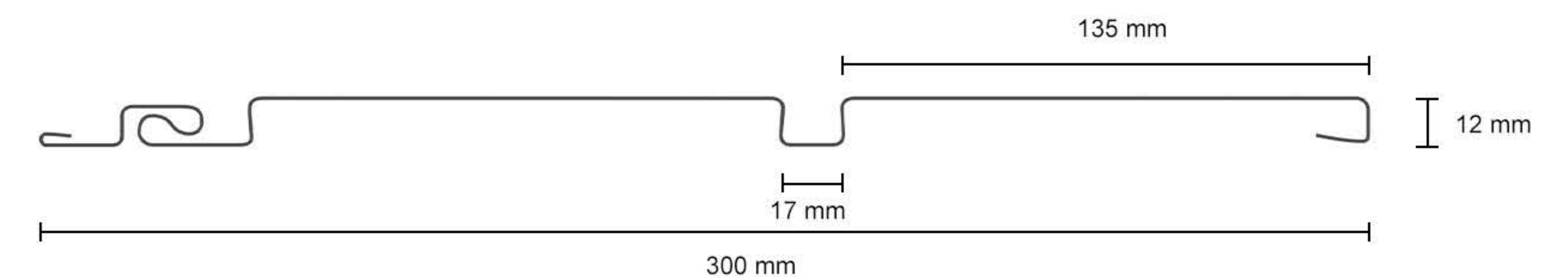

FEATURES



LIGHT WEIGHT



FIRE RETARDANT



MAINTENANCE FREE



NO VOC



WATERPROOF



REAL WOOD FEEL



SHADES



PINE WOOD
(15)



MAPLE WOOD
(16)



BIRCH
(17)



GOLDEN OAK
(18)



WALNUT
(19)



WEATHERED GREY
(20)



MAHOGANY
(28)



CHESTNUT
(29)



OAK WOOD OCRE
(30)



ROYAL NUT
(33)



ASHWOOD GREY
(34)



SPICED WALNUT
(36)

**Product colour may vary from that shown in picture.



THE PERFECT CEILING SYSTEM

Unlock a world of endless possibilities for your ceiling with PARÉ INNOV+ Panels. Choose from a captivating spectrum of natural wood shades, seamlessly blending rustic charm with modern elegance.

Mix and match different designs to create your own unique masterpiece, thanks to our revolutionary interlocking technology. Installation is a breeze, leaving you with stunning visuals and minimal maintenance - say goodbye to rust and rotting ceilings!

Built to last with a 10-year warranty, INNOV+ Panels offer exceptional rigidity and peace of mind. More than just ceilings, they're an invitation to elevate your space with nature's timeless elegance, effortlessly. Discover the endless possibilities with PARÉ INNOV+ Panels today.



LOUVERS

PANELS

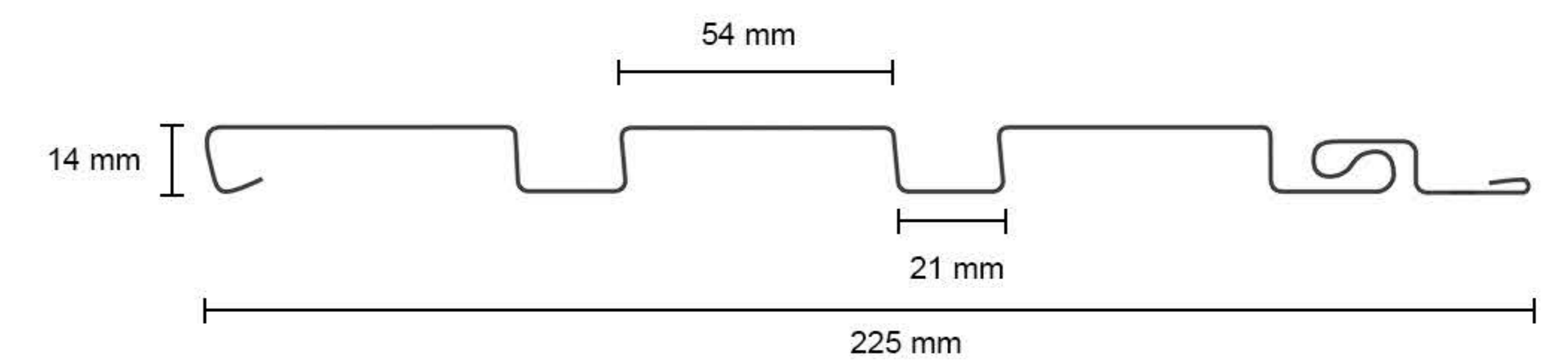

PARÉ Louvers Panels transcend mere wall and ceiling solutions, offering unmatched stability and creative possibilities for your space. Their enhanced groove design, featuring sharper angles and smaller intervals, not only bolsters structural integrity for vertical applications but also unlocks a world of captivating shadow play.

SHADES



MAHOGANY
(28)



OAK WOOD OCRE
(30)



ROYAL NUT
(33)



ASHWOOD GREY
(34)



BEECH WOOD
(35)



SPICED WALNUT
(36)



STATUARIO
(61)



ARMANI GREY
(62)



PORTORO
(63)

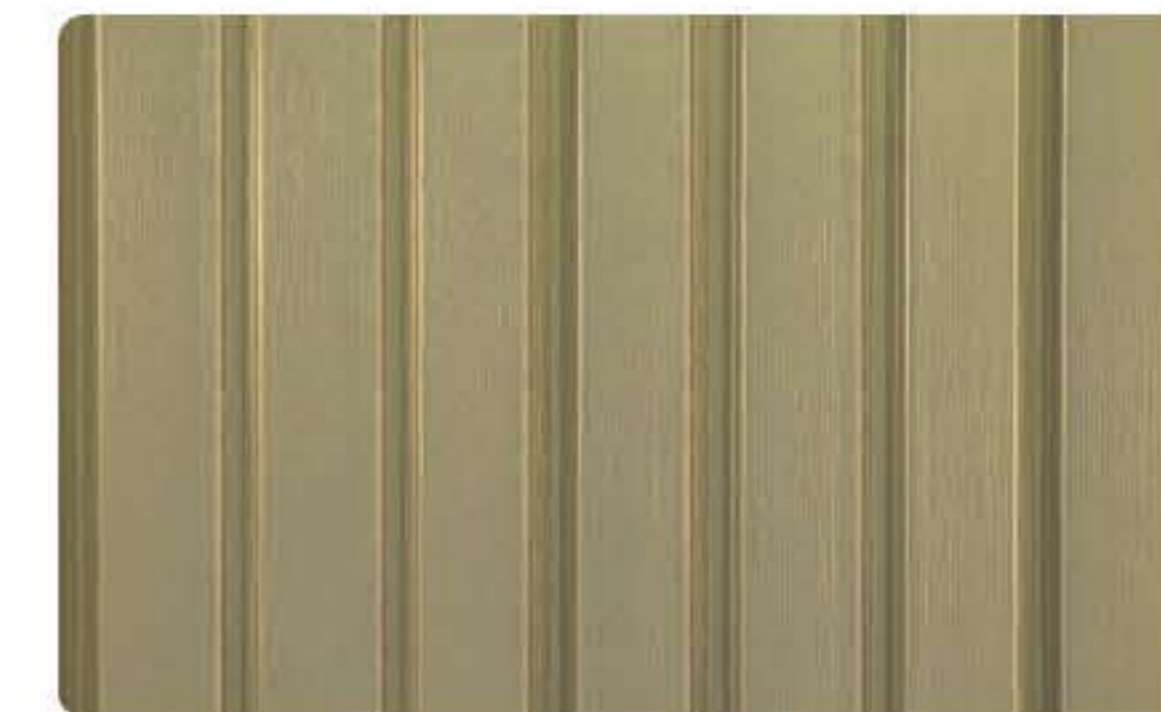

GOLD
(40)

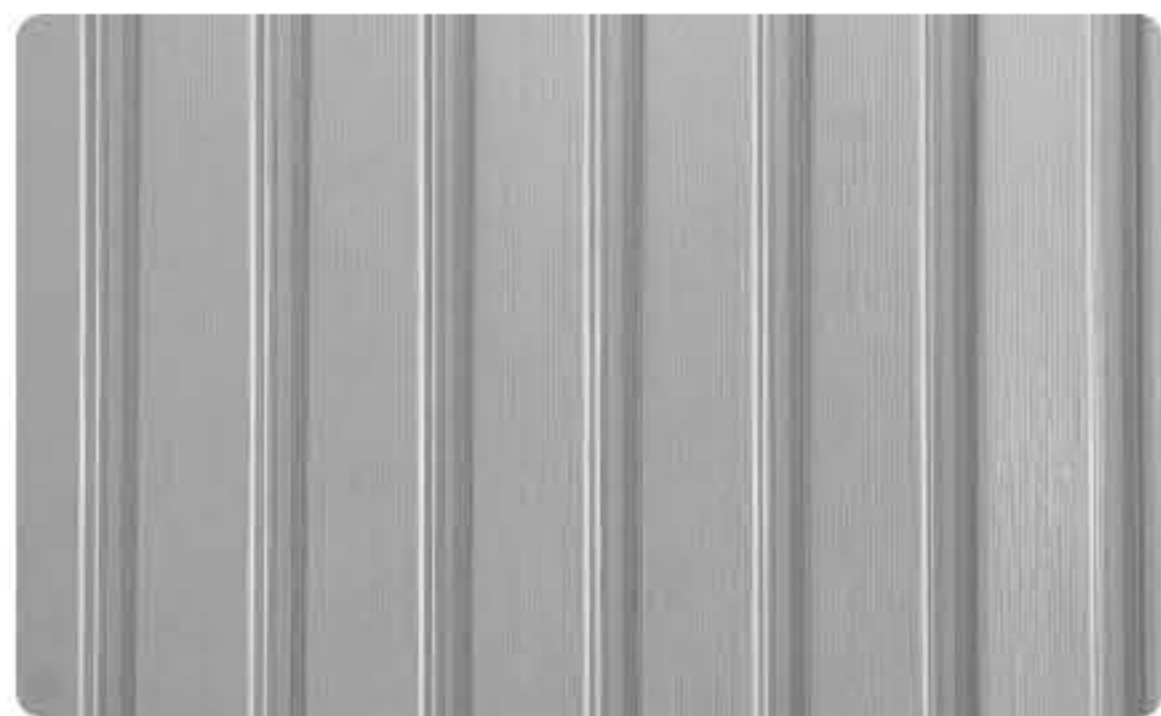

SILVER
(41)



COPPER
(42)



PEARL
(91)

**Product colour may vary from that shown in picture.

FEATURES



LIGHT WEIGHT



FIRE RETARDANT



MAINTENANCE FREE



NO VOC



WATERPROOF



REAL WOOD FEEL



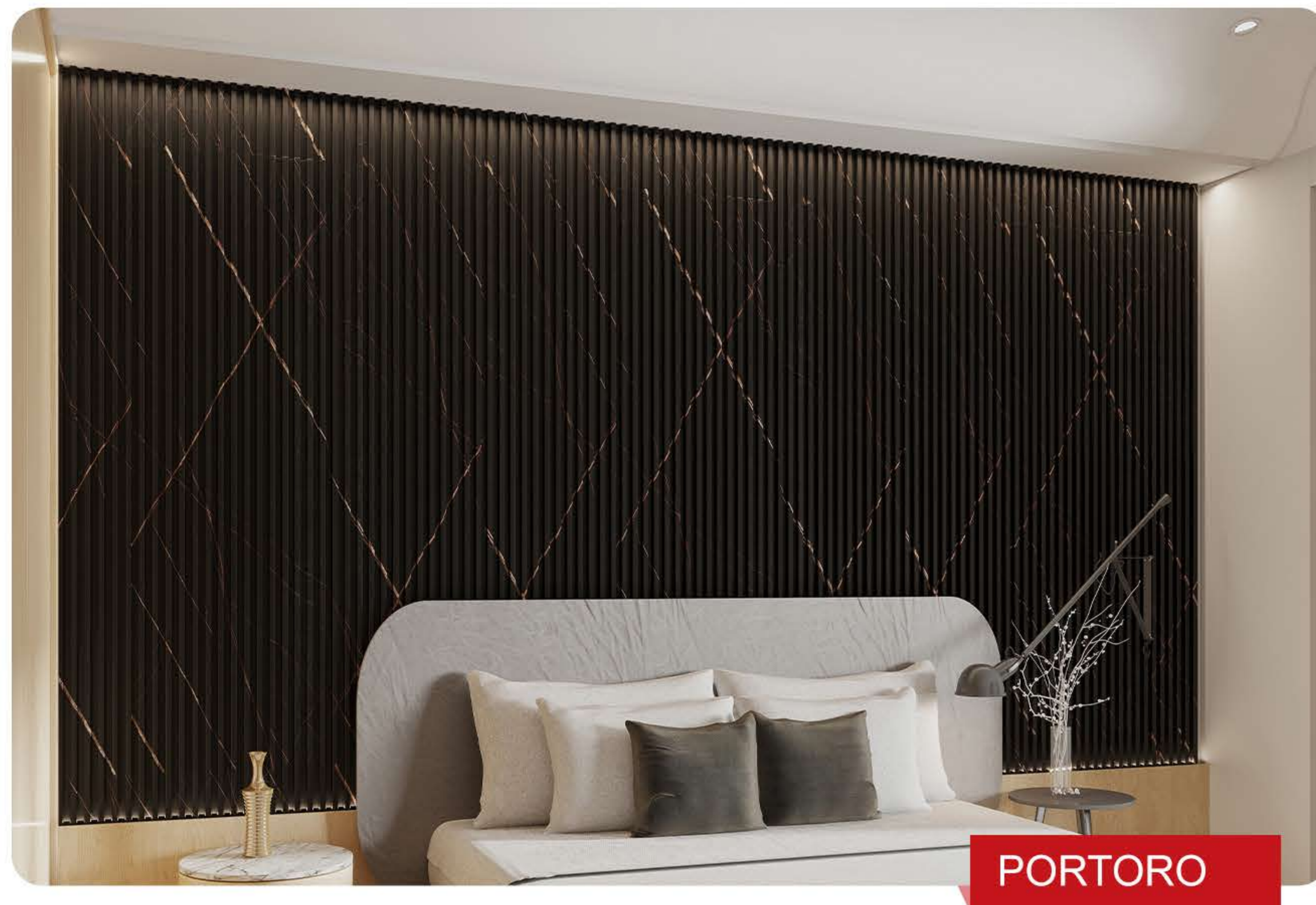

NEW SHADES

Discover an array of exquisite shading options with Louvers Panels, featuring captivating tones inspired by marble, metallic, and fabric hues. Drawing inspiration from renowned designers, we have curated a collection that seamlessly meets the diverse preferences of consumers. Recognizing a gap in the market, we diligently addressed the absence of these unique shades, ensuring a comprehensive solution for our customers.

Our color palette is derived from nature's elements, resulting in a remarkably realistic appearance once installed. Elevate your space with Louvers Panels and experience the perfect blend of style and functionality.

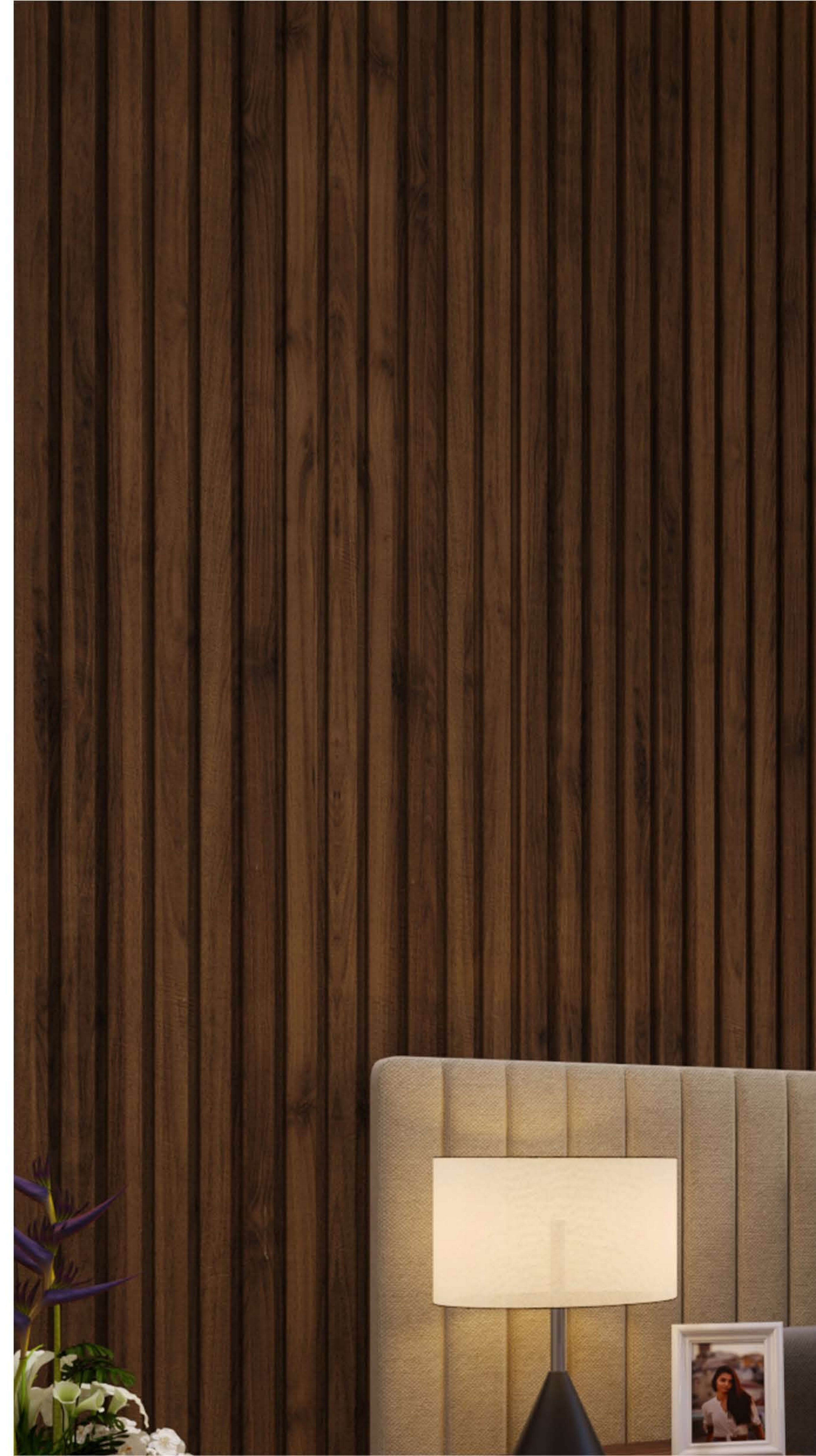



VERTICA PANELS

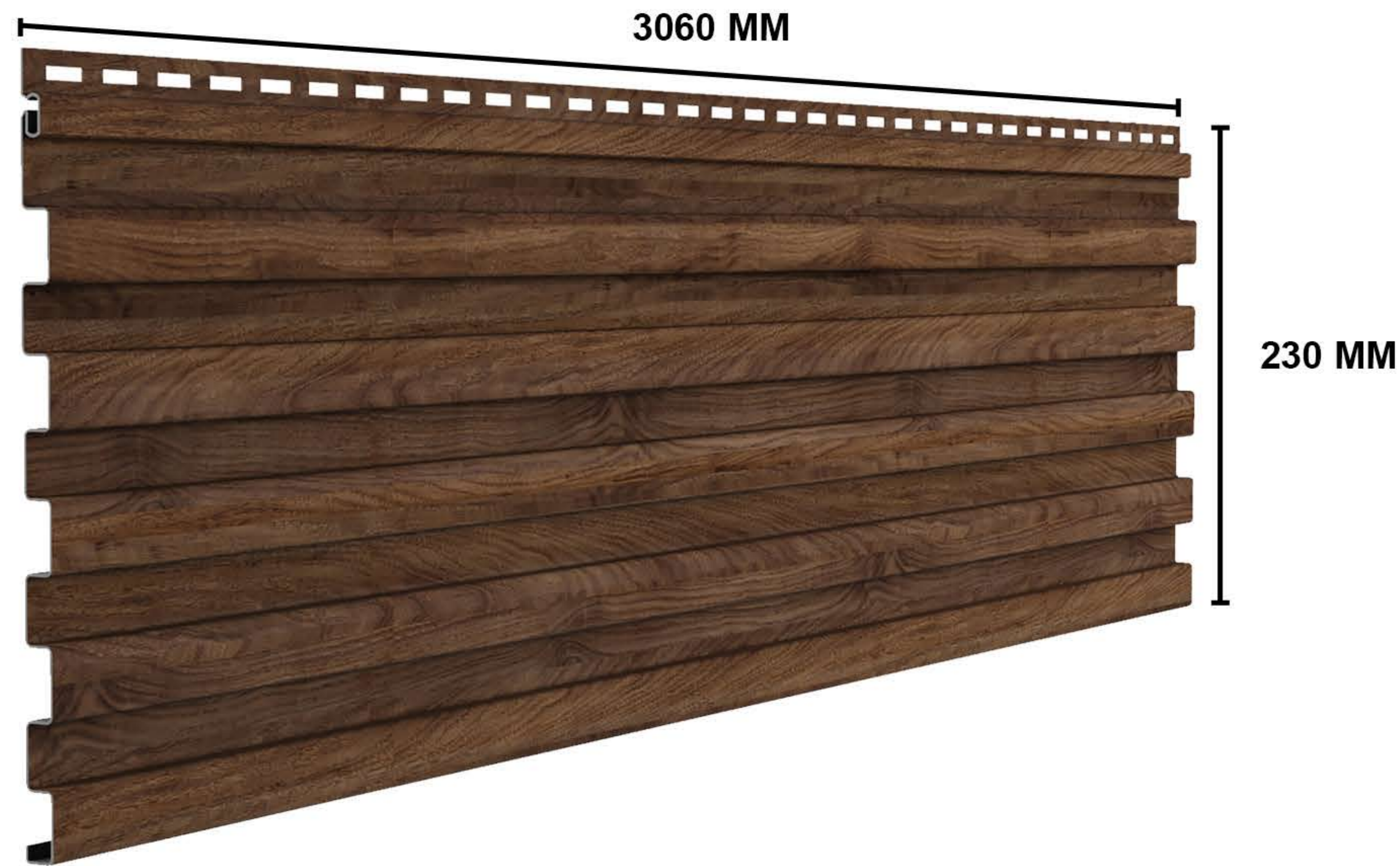

A revolutionary choice for elevating interior spaces. Crafted with precision, our panels feature shorter grooves strategically designed to enhance shadow play, adding a dynamic and visually captivating element to your surroundings.

Experience unparalleled versatility with Vertica Panels, offering a wide range of shade options to suit your unique aesthetic preferences. We take pride in providing panels with increased height, ensuring a grand and impactful presence in any setting.

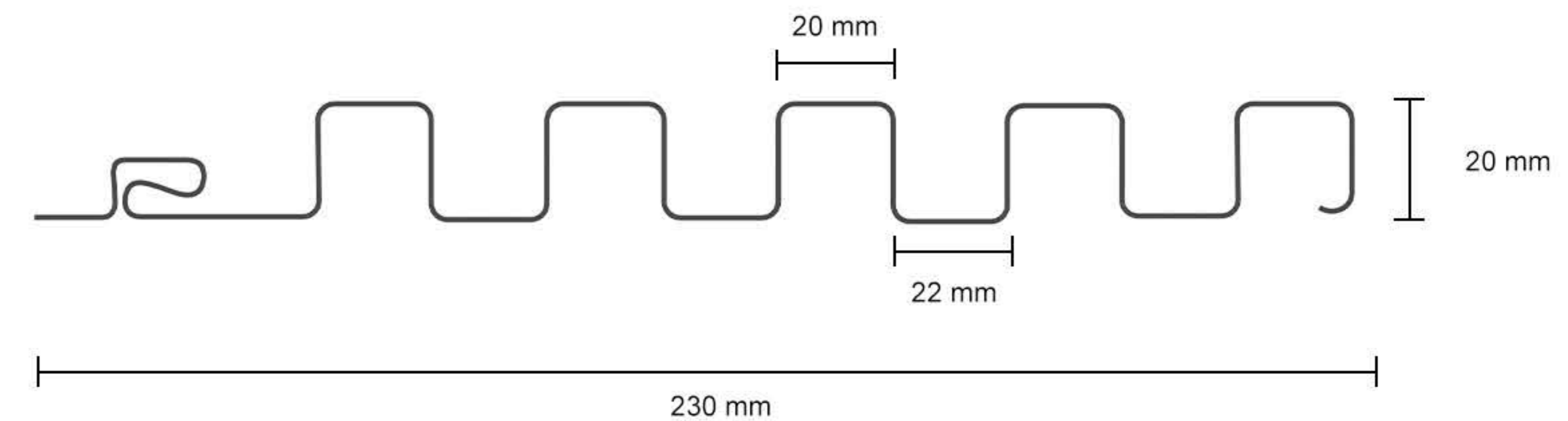

SHADES



MAHOGANY
(28)



OAK WOOD OCRE
(30)



ROYAL NUT
(33)



ASHWOOD GREY
(34)



BEECH WOOD
(35)



SPICED WALNUT
(36)



STATUARIO
(61)



ARMANI GREY
(62)



PORTORO
(63)



GOLD
(40)



SILVER
(41)



COPPER
(42)



PEARL
(91)

**Product colour may vary from that shown in picture.



FEATURES



LIGHT WEIGHT



FIRE RETARDANT



MAINTENANCE FREE



NO VOC



WATERPROOF



REAL WOOD FEEL

NO PLY REQUIRED



Our innovative technology eliminates the need for plywood during installation. With direct screwing to walls, it significantly reduces installation time, minimizes dirt and dust, all while saving costs. Experience hassle-free installation with cutting-edge efficiency.

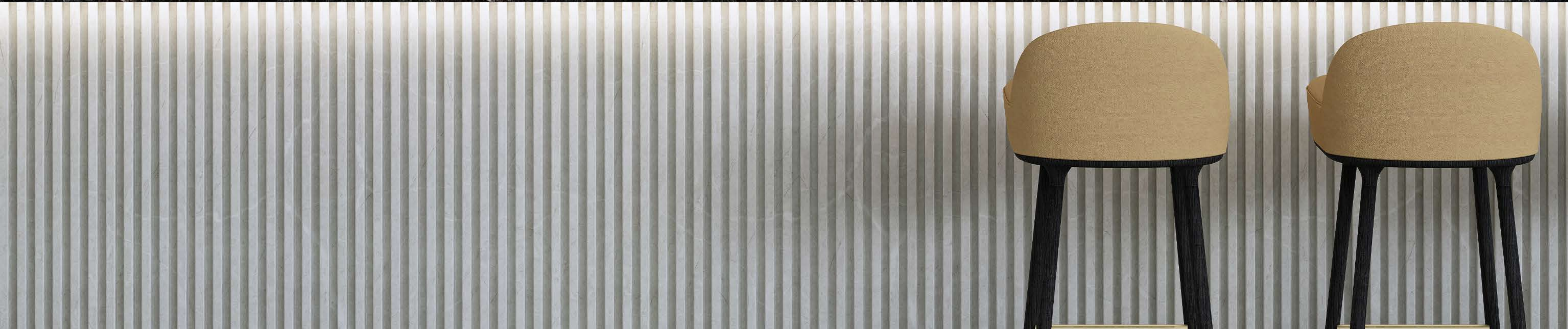

INSTALLATION

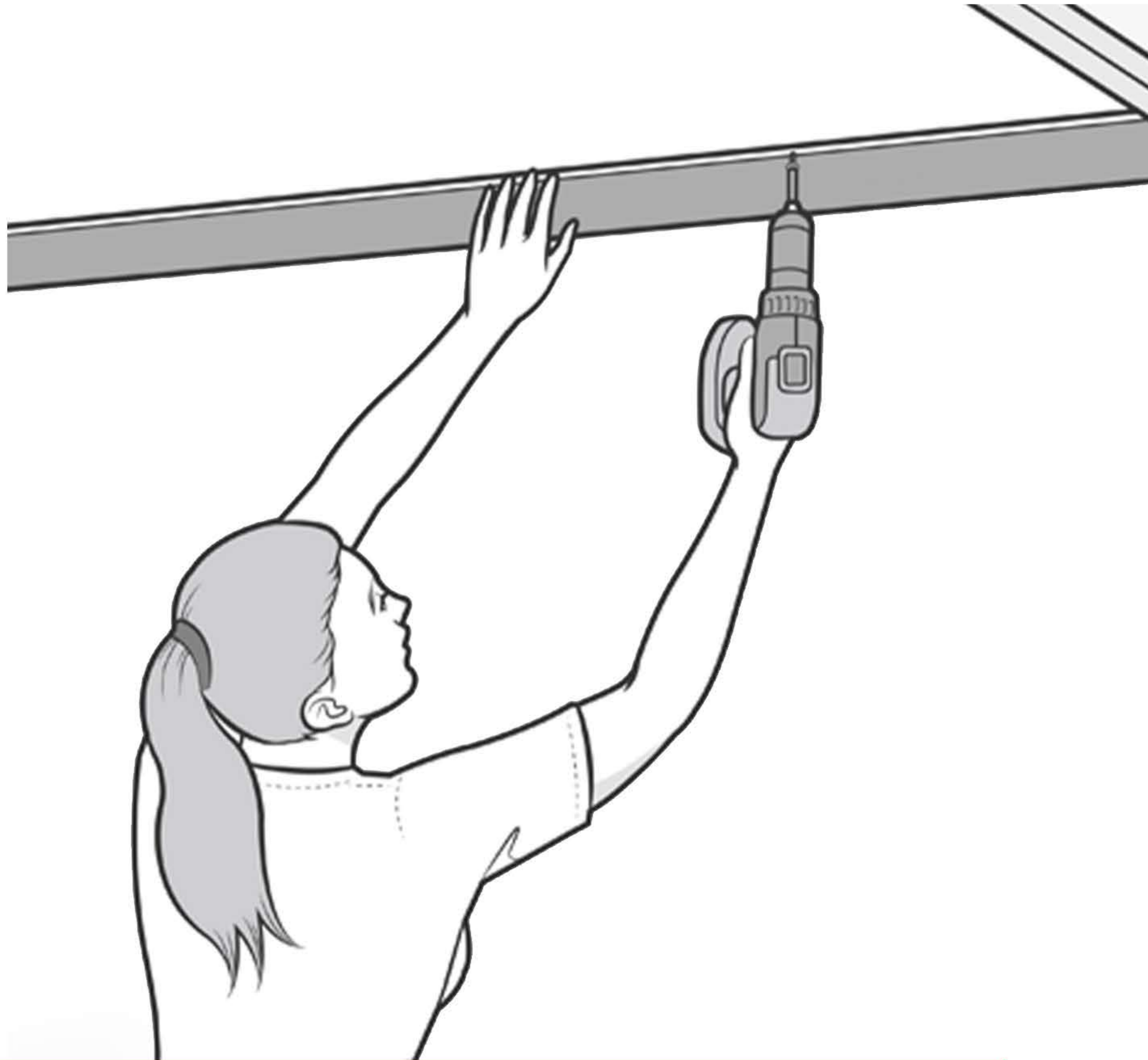

DIRECTLY SCREW TO WALL / CEILING

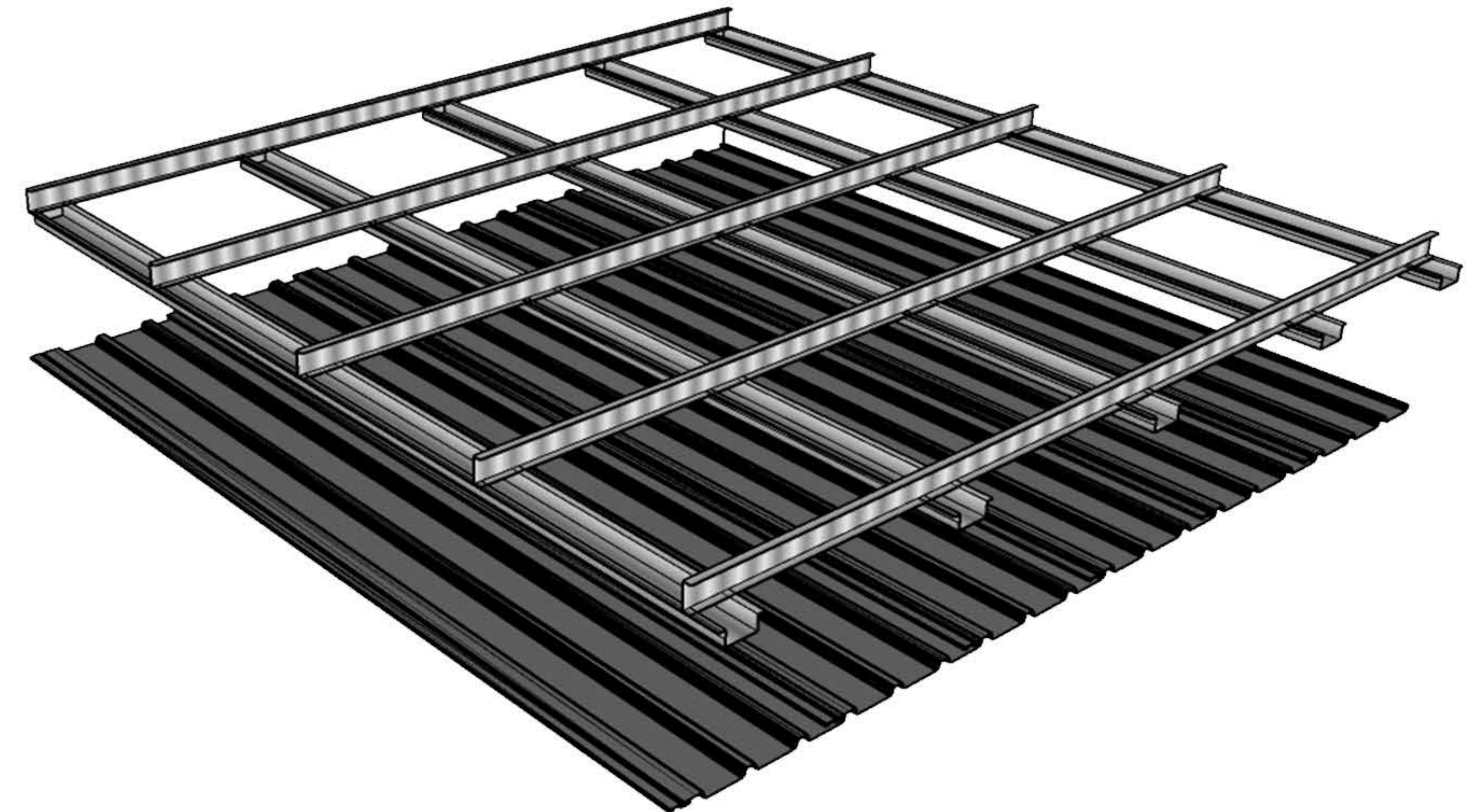

GI / ALUMINIUM FRAMING

PARÉ Panels can be securely screwed directly to the wall or using GI/Aluminum framing for ceiling installation. This technology ensures a swift and clean installation process, minimizing dust and labour requirements. Embrace the future of ceiling and wall systems with PARÉ an epitome of efficiency and innovation in interior design.

TRIMS

J TRIM

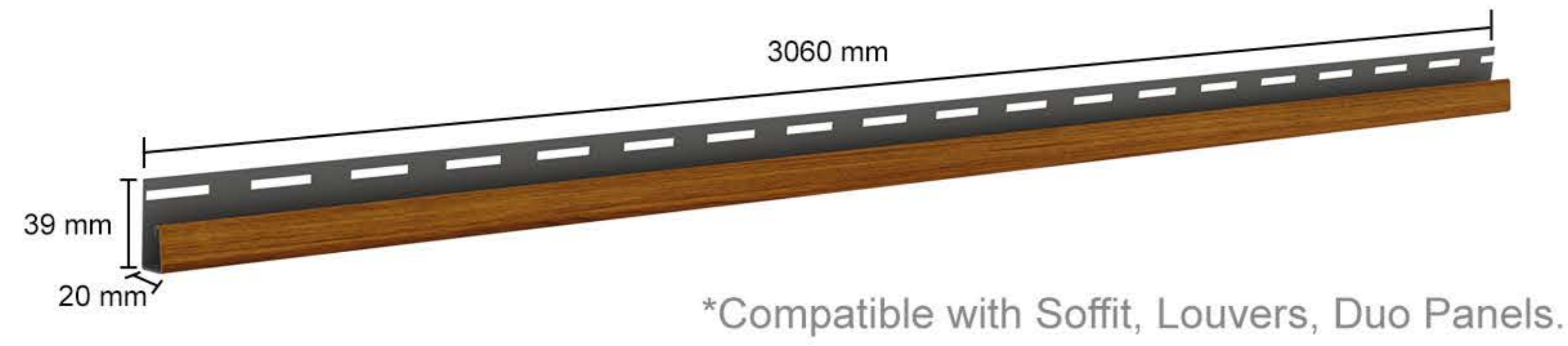

L TRIM

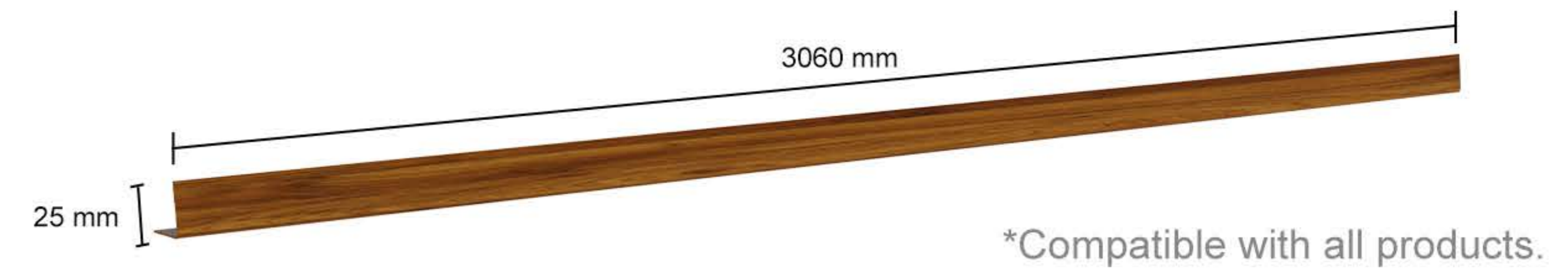

J TRIM LARGE

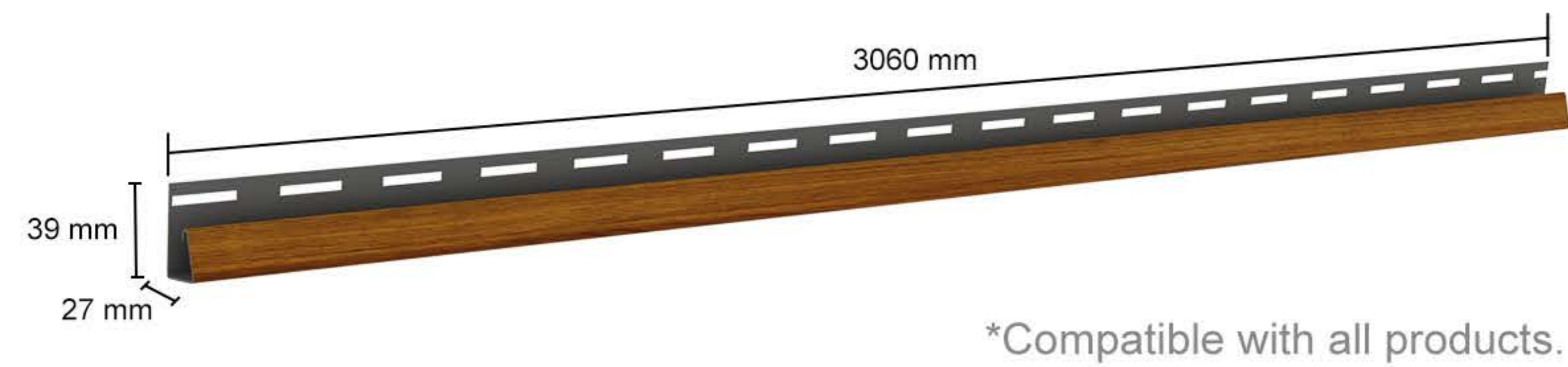

L TRIM REVERSE

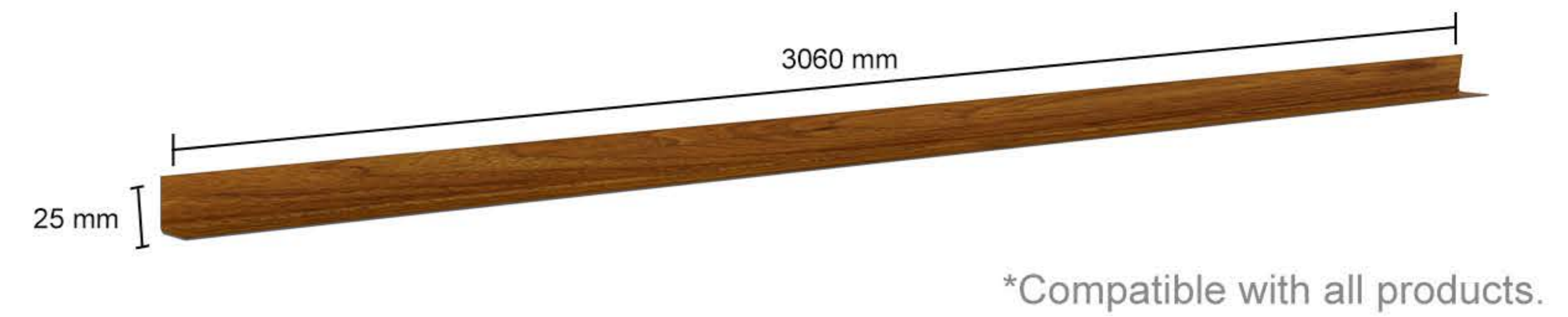

J TRIM PRO

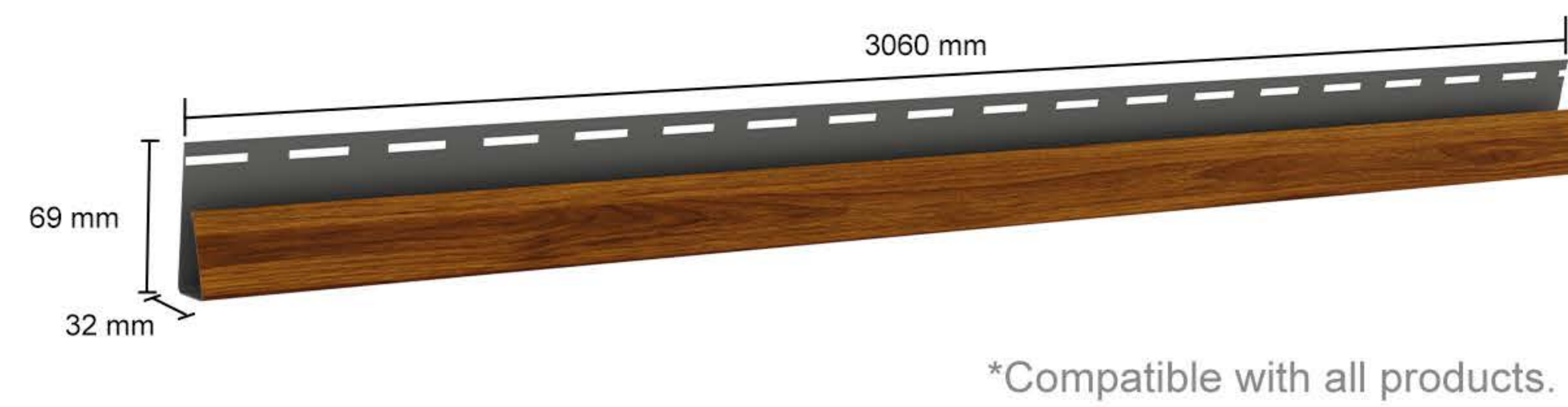

INSIDE CORNER



T TRIM



OUTSIDE CORNER



CUSTOM SIZING

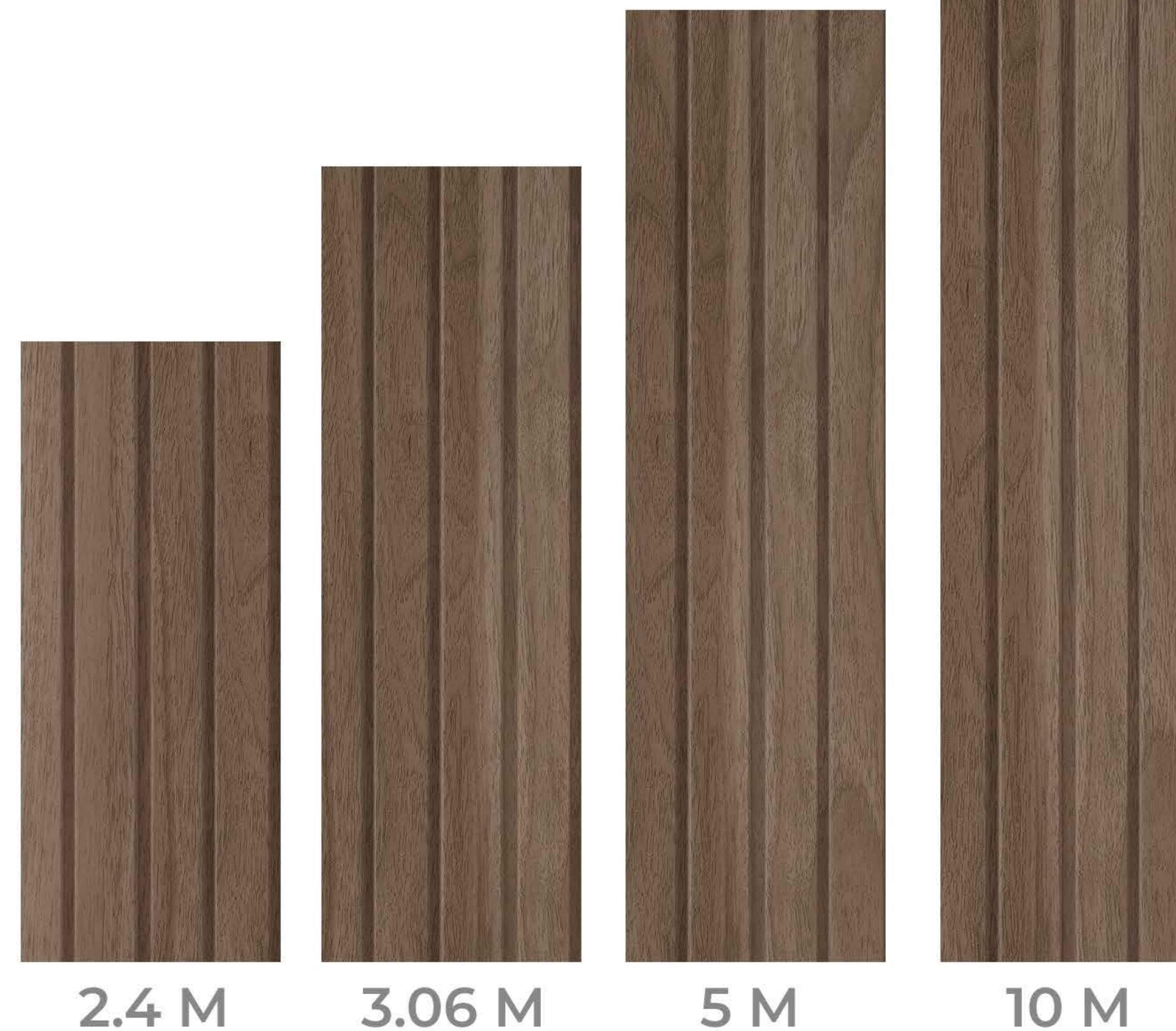

PARÉ presents tailored solutions with custom sizing for INNOV+ Panels, allowing for the creation of panels ranging from 2m to more than 10m in length, imparting a seamless and aesthetically pleasing appearance.

The advantage of custom sizing extends beyond visual appeal, offering a cost-effective solution that enhances the overall aesthetic of a space. Experience the elegance of INNOV+ Panels, where customized dimensions seamlessly blend with practical cost efficiency.

VERSATILITY

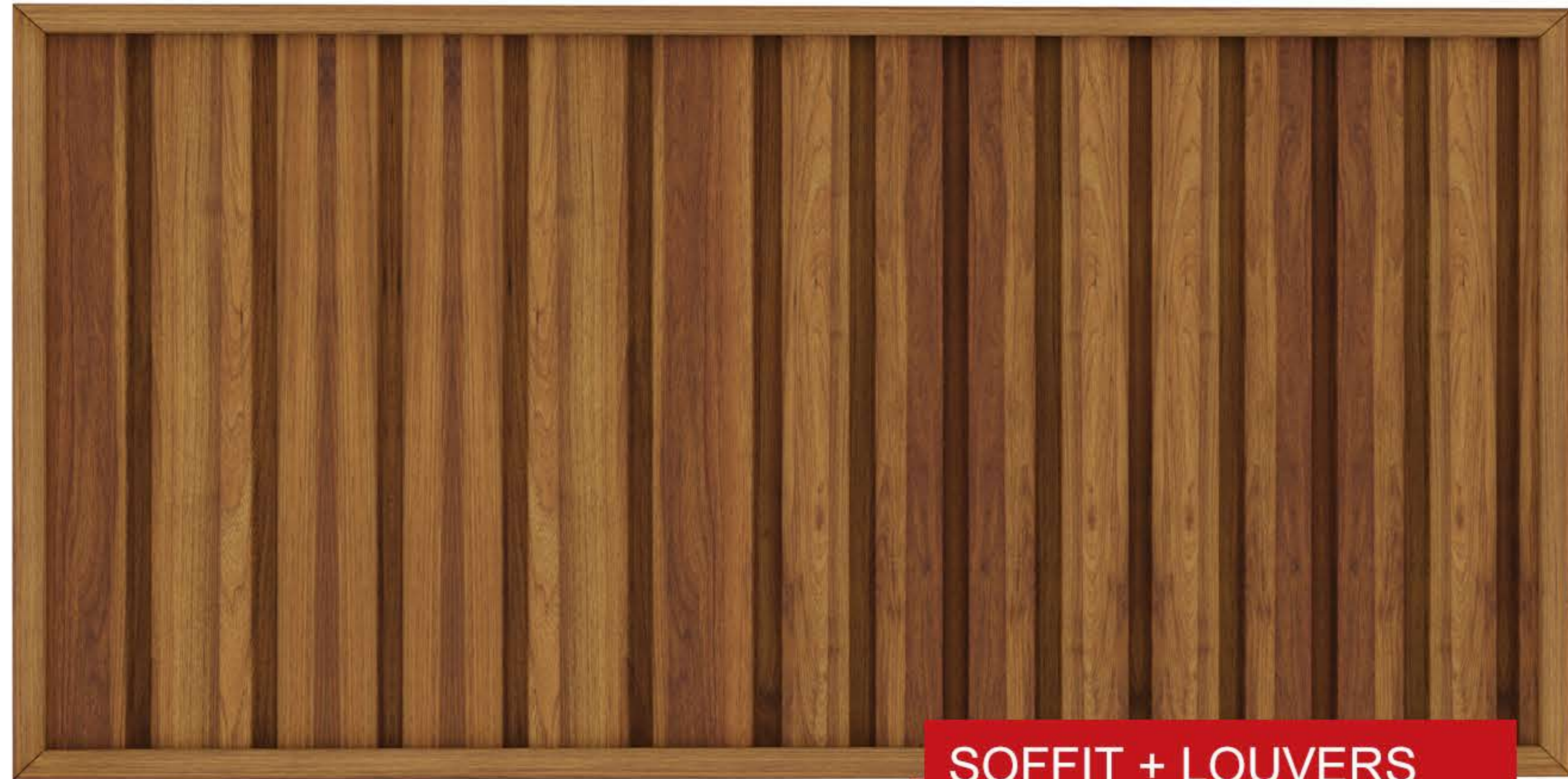

SOFFIT + LOUVERS



DUO + VERTICA

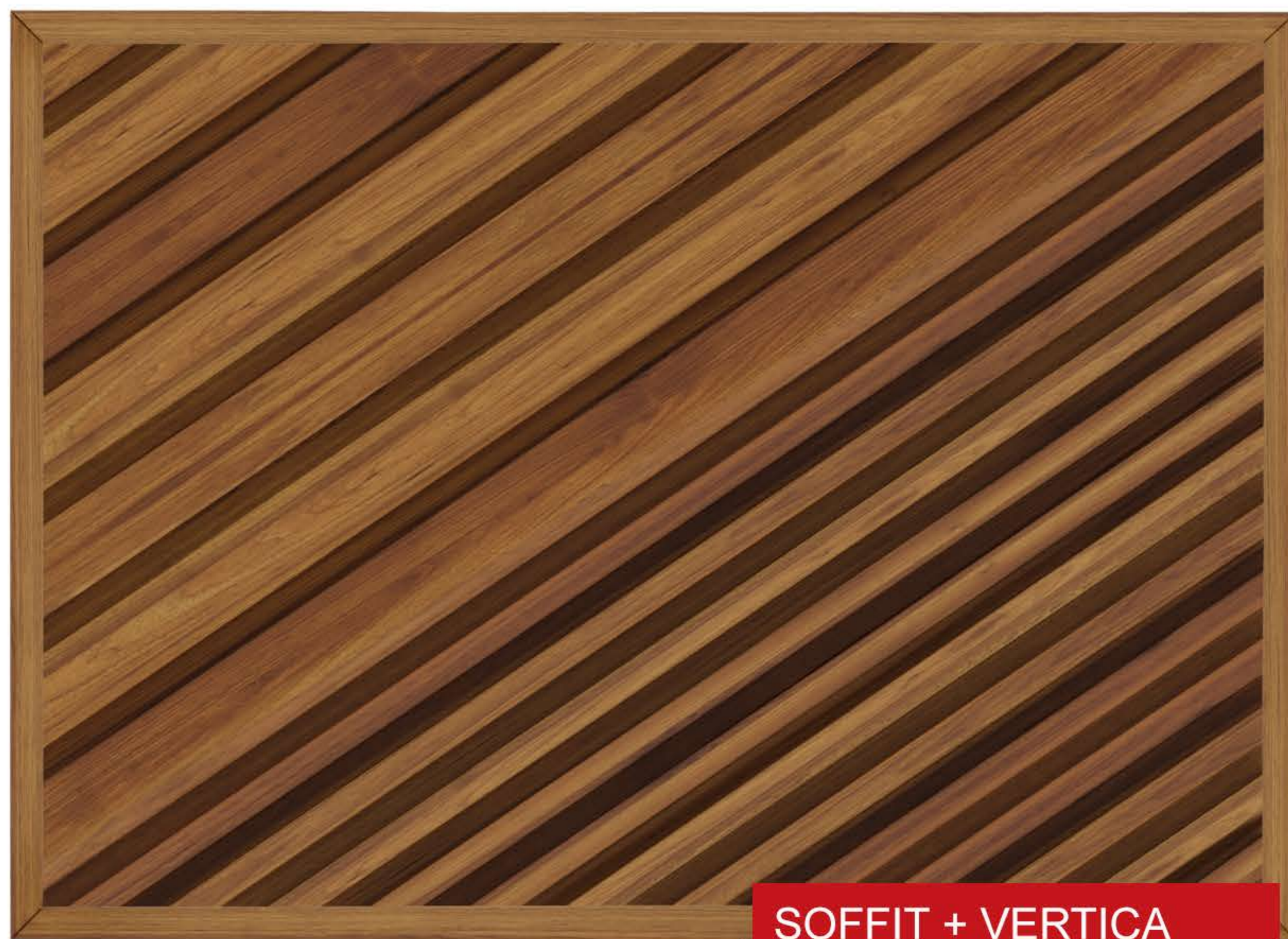

SOFFIT + VERTICA

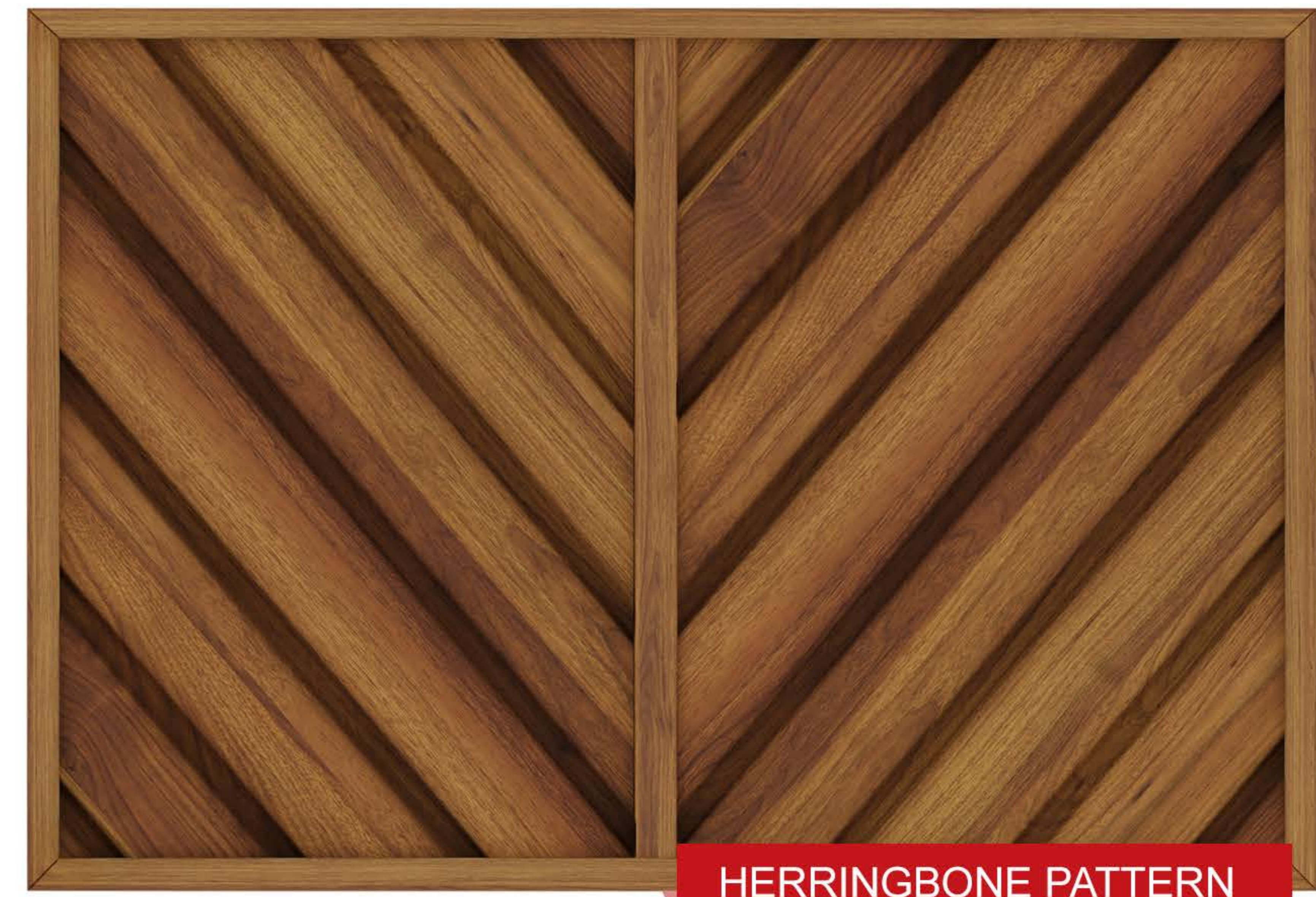

HERRINGBONE PATTERN

SOFFIT & LOUVERS





SHADE CHART

	SOFFIT	DUO	LOUVERS	VERTICA
Golden Oak	✓	✓		
Birch	✓	✓		
Maple Wood	✓	✓		
Walnut	✓	✓		
Pine Wood	✓	✓		
Weathered Grey	✓	✓		
Spiced Walnut	✓	✓	✓	✓
Oak Wood Ocre	✓	✓	✓	✓
Chest Nut	✓	✓		
Mahogany	✓	✓	✓	✓
Royal nut	✓	✓	✓	✓
Ashwood Grey	✓	✓	✓	✓
Graphite	✓			
Super White	✓			
Beech Wood			✓	✓
Gold			✓	✓
Silver			✓	✓
Copper			✓	✓
Armani grey			✓	✓
Statuario			✓	✓
Portoro			✓	✓
Pearl			✓	✓
Artisan oak	✓			
Imperial Nut	✓			

TECHNICAL DECLARATION

RELEVANT CODES AND REGULATIONS COMPLIANCE :

Conforms to ASTM Specifications D-4477

Colour : Uniformity is Spectrophotometrically Controlled.

Lock : Optically Measured and Controlled.

PRODUCT TEST DATA :

Tests	Results
Impact Resistance	No deformation observed. (Tested at 50 LBS)
Tensile Strength, MPa:	> 37.0
Tensile Modulus, MPa:	> 2000
Surface Distortion	None at 120F
Length:	Within 1/4" of specification
Lock Control:	Complies
Colour Change:	<2 grayscales [16hrs under 1200W/m2 UV radiation at 50 degrees}
Squareness	<1/8" of square

DECLARED PERFORMANCE :

ESSENTIAL CHARACTERISTIC	PERFORMANCE	HARMONISED TECHNICAL SPECIFICATION
Reaction to fire EN 13501-1	D-s3;d0	EN 13245-2:2009/AC:2010
Release of dangerous Substance	NPD	
Durability	A.4.65	

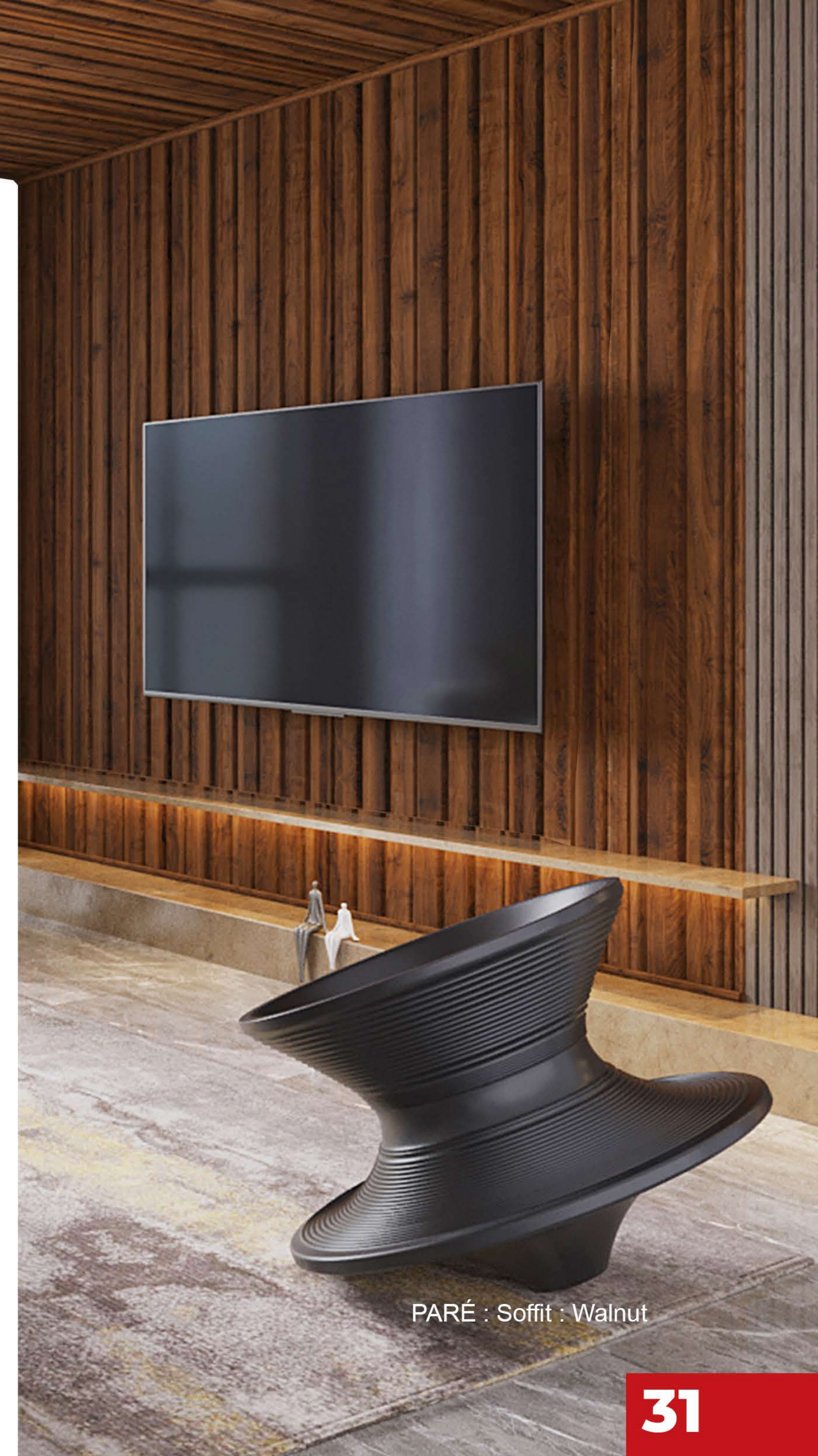

PARÉ : Soffit : Walnut



Mfg. & Marketed by
PARÉ INNOVATIONS Pvt. Ltd.

101 - 103, Jai Commercial Complex, Cadbury Junction,
Thane (W), Maharashtra, India - 400601



www.pareindia.com



@pareindia



+91 8356954856



hello@pareindia.com

