

A practical solution for small storage spaces

Now even the smallest spaces in the kitchen can be used. With its idea for narrow cabinets, Blum creates additional storage space thanks to diagonally offset runners – without compromising on stability or quality of motion.

blum





Proven Blum quality of motion

The idea for narrow cabinets features the proven Blum quality of motion. Low opening forces, the smooth running action and the BLUMOTION adaptive dampening system. This ensures a silent and effortless closing action with high quality of motion. The solution can also easily be pulled out, so everything can be conveniently accessed, even in the furthest corner.

Optimum stability and load bearing

Diagonally offset runners ensure improved lateral stability and a high load bearing capacity of up to 20 kg per base cabinet.

Uniform appearance

The implementation in combination with the box system TANDEMBOX or with the runner systems TANDEM and MOVENTO enables a consistent look and a uniform appearance.

Familiar ease of assembly and adjustment

The use of Blum standard fittings enables the familiar simple and convenient adjustment and assembly.

Diverse implementation options

The consistent use of Blum fittings enables the narrow cabinets concept to be covered by the existing programme.

The solution can be used in combination with TANDEMBOX and with the TANDEM and MOVENTO runner systems.

blum



TANDEMBOX

The solution for narrow cabinets is compatible with all TANDEMBOX programme lines.

For cabinet width of 200 mm minimum.



TANDEM

With the runner system, narrow wooden cabinets can be implemented throughout the entire living area.

For cabinet widths starting at 150 mm.



MOVENTO

The quality of motion of MOVENTO is also noticeable in narrow cabinets.

For cabinet width of 200 mm minimum.



TANDEMBOX



Planning information

Space requirements in cabinet

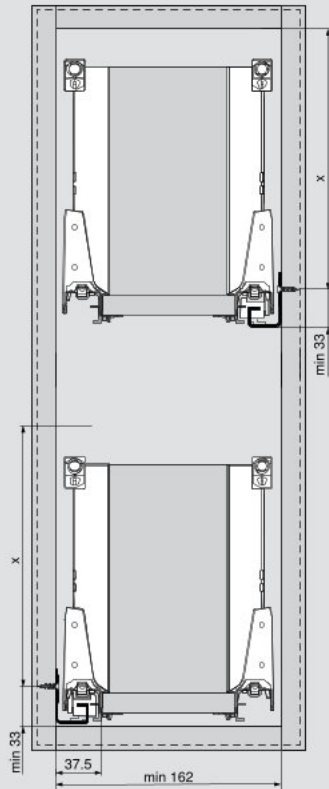

X =

Height	TANDEMBOX plus	TANDEMBOX antaro	TANDEMBOX intivo
M	63.5 mm	65.5 mm	65.5 mm
K	95.5 mm	97.5 mm	-
B	127 mm	127 mm	-
C	159 mm	163 mm	159 mm
D	191 mm	195 mm	191 mm

Front installation dimensions

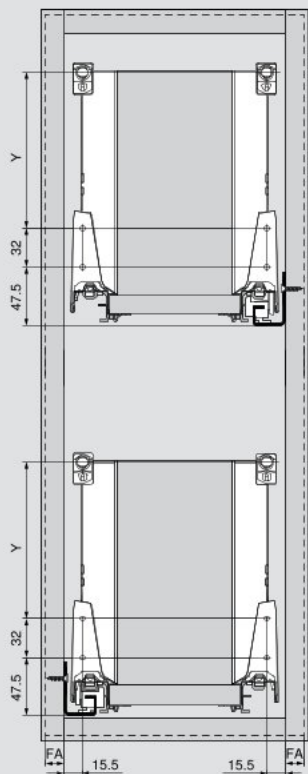

FA = front overlay

Y =

Height	TANDEMBOX plus	TANDEMBOX antaro	TANDEMBOX intivo
M	-	-	-
K	32 mm	32 mm	-
B	64 mm	64 mm	-
C	96 mm	96 mm	96 mm
On K drawer side	32/64 mm	-	-
D	128 mm	128 mm	96 mm
With double gallery	64/64 mm	64/64 mm	-
On K drawer side	-	32/96 mm	-

Back installation dimensions

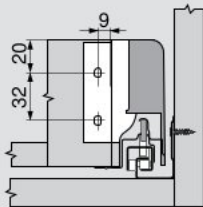

Height M

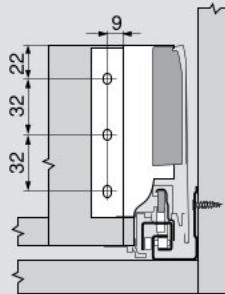

Height K

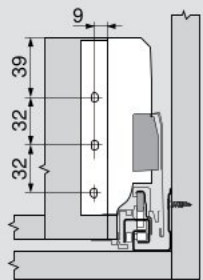

Height B

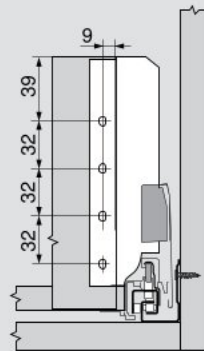

Height C

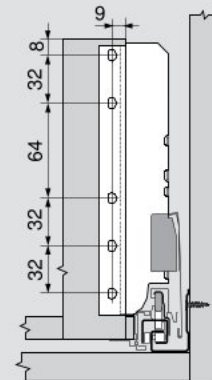

Height D

Cutting dimensions for 16 mm chipboard

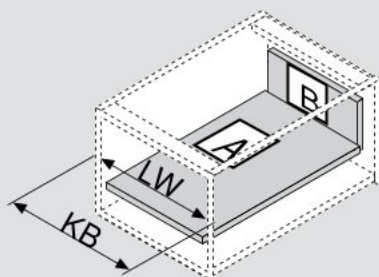
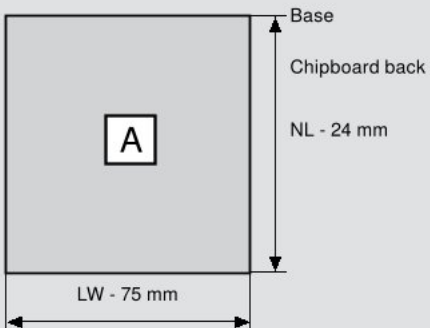
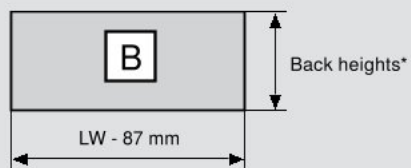

KB = cabinet width
LW = inner cabinet width
NL = nominal length

* Back heights

Height	TANDEMBOX plus	TANDEMBOX antaro	TANDEMBOX intivo
M	84 mm	84 mm	84 mm
K	116 mm	116 mm	-
B	135 mm	135 mm	-
C	167 mm	167 mm	167 mm
D	199 mm	199 mm	199 mm

i Note

For order specifications for standard TANDEMBOX components, please see the respective product brochures or the catalogue.

Drawer

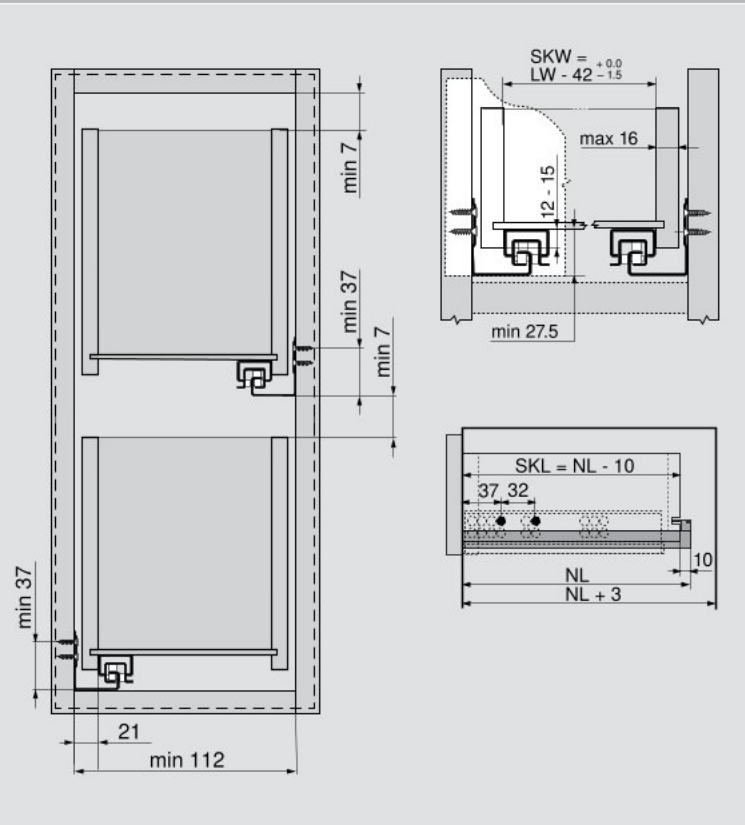

Locking device feature of drawer assembly

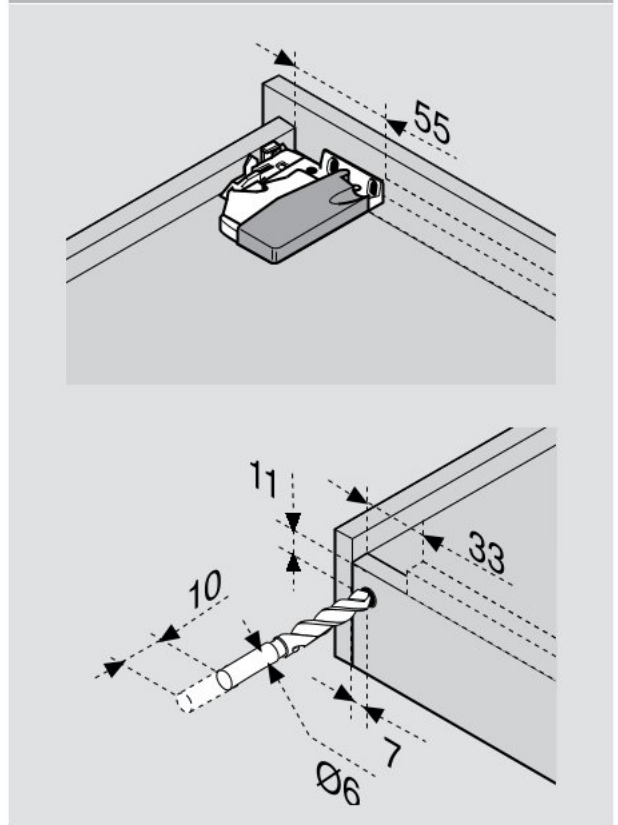

Peg variant of drawer assembly

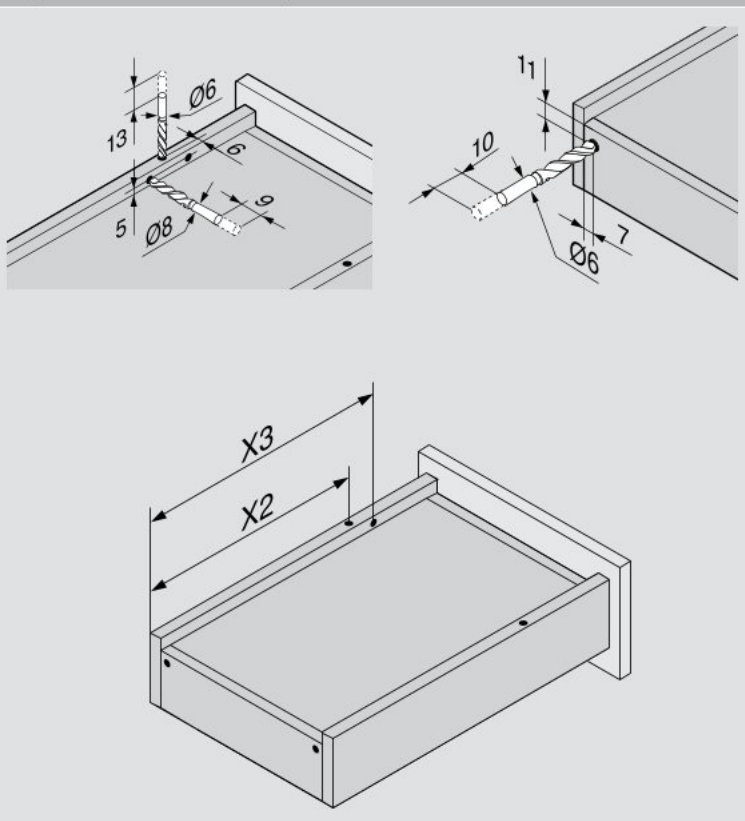

Tandem plus-561H

Nominal length	Pegs	Lift-off stop
NL (mm)	X2 (mm)	X3 (mm)
260	205	185
285	220	200
310	230	242
335	245	257
360	275	287
385	285	297
410	300	344
435	310	354
460	335	379
485	350	394
510	360	436
535	375	451
560	405	481

i Note

For order specifications for standard TANDEM components, please see the respective product brochures or the catalogue.

Drawer

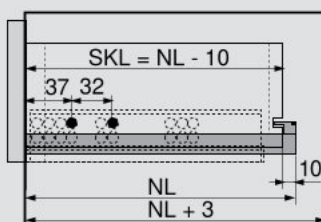
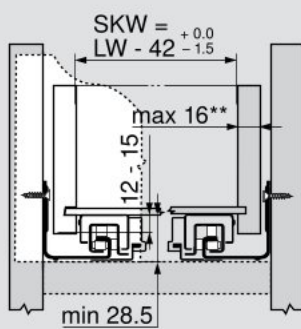
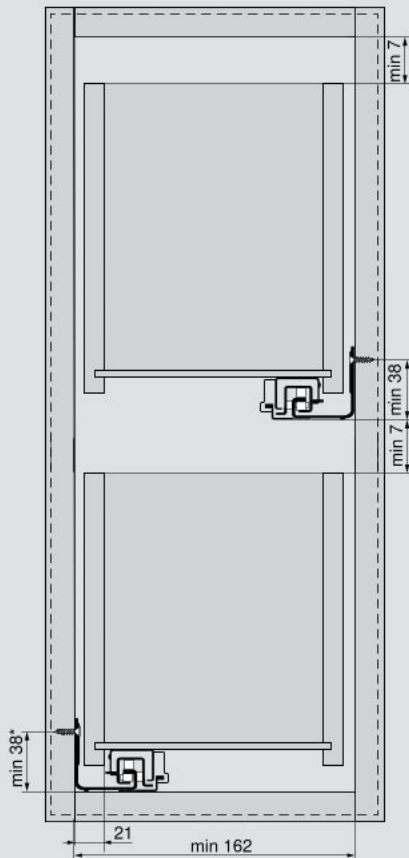

* + 1 mm for assembly of the cabinet profile on the horizontal cabinet side

** Limited side adjustment for a drawer side panel thickness of 16 mm, but with full tolerance utilisation of the internal drawer width SKW

Drawer assembly

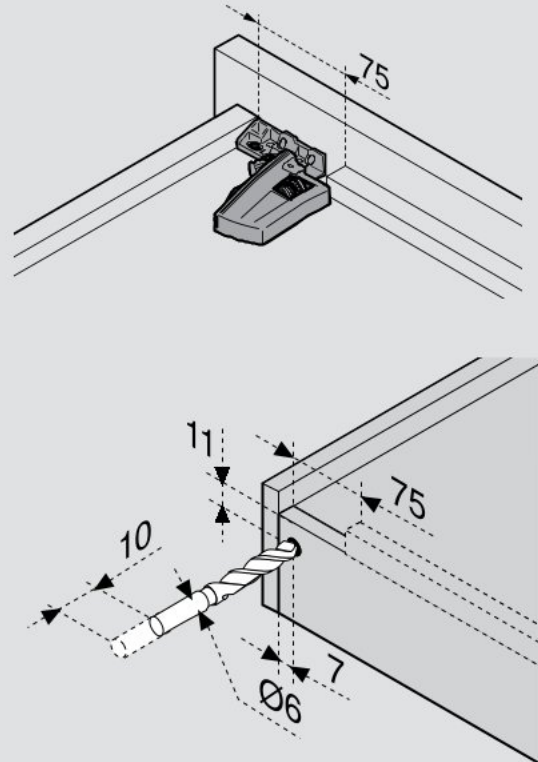

i Note

For order specifications for standard MOVENTO components, please see the respective product brochures or the catalogue.

Blum

Founded over 60 years ago by Julius Blum, today Blum is an internationally active family-owned company. Its strategic business fields include hinge, pull-out and lift systems. All our product developments revolve around perfecting motion.





Blum in Austria and around the world

Blum operates seven plants in Austria (Vorarlberg) as well as further production sites in Poland, the USA and Brazil and 27 subsidiaries/representative offices. The company supplies more than 100 markets. The Blum Group employs 5.900 people in total.



Global customer benefits

"Whether manufacturer, distributor, fitter or kitchen user – everybody should personally enjoy the benefits of Blum products" – that is Blum's philosophy on global customer benefits.

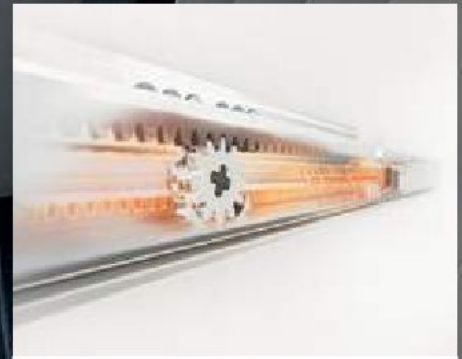

Innovation

Supporting customers with innovative fitting solutions and securing long-term success for the company requires consistent investment in research and development, in plants and facilities and in employee training. With more than 1.200 registered trade marks around the world, Blum is one of Austria's most innovative companies.



Quality

The comprehensive concept of quality at Blum applies not only to products. Services and our cooperation with customers and partners should also meet the same quality demands.



Environment

At Blum, we believe that responsible ecological behaviour has long-term economic benefits. The longevity of products is just one important aspect of many. Further important measures include the use of environmentally friendly processes, intelligent use of materials and prudent energy management.



DYNAMIC SPACE

Good workflows, sufficient storage space and ease of use are important features of a practical kitchen. With its ideas for practical kitchens, Blum aims to bring function, convenience and ergonomics to the interior of furniture.

