

The
first
100
years.

The background features a large, light tan triangle pointing upwards from the bottom left. A large, dark blue circle is positioned on the right side, partially overlapping the triangle. The text is located in the upper left quadrant, overlaid on the white background.



Dear Reader,

2023 marks a huge **milestone in the history** of our company. Häfele is now **one hundred years old**, and we are taking the opportunity of this extraordinary anniversary to pause and reflect intensively on the growth that's taken us from a small hardware store in the Black Forest (Germany) to a global company.

In addition to extraordinary people who have guided the company's fortunes with far-sightedness, what stood out prominently for us was our ability to forge **strong partnerships** that have been fundamental in shaping our progress and achieving the milestones we stand before today. We sought to build an ecosystem that fostered a sense of community, respect, and shared purpose and over the years, this approach has proven to be the cornerstone of our achievements. Together, we have weathered economic downturns, navigated shifting market trends, and embraced technological advancements.

Therefore, it wouldn't be incorrect to state that it has been **courage and optimism**, above all that have carried us as an organization through stormy times. These qualities have also defined Häfele from the very beginning and characterised the founders back in the day. The original 2-man business which was a specialist hardware store led by **Adolf Häfele and Hermann Funk**, has developed into a global company, Häfele SE & Co KG, with subsidiaries in **38 countries, 8,000 employees** and more than **1,50,000 customers**.

Standing on the threshold of the next phase of our journey, we realise that it was courage and optimism along with an **unwavering alliance with our employees, vendors, suppliers and above all our customers**, that enabled us to change continuously, to break new ground and not only to think ahead, but also to actively implement these forward-thinking ideas.

As we foray into the next 100 years, Häfele presents its future-oriented brand purpose (which will be at the very core of our strategic outlook) - **"Maximising the value of space. Together."** The new brand claim aims to consolidate our attitude, our competences, the developments inside and outside of our company and the strategic decisions we have made in the past years and decades. And as we transition between the first and second century, we aim to pour our collective experiences that have brought us here into a connected mould – our purpose, that will function as a starting point for a shared journey into the future and will act as a powerful compass for us.

Needless to say, we excitedly look forward to shaping this - perhaps new, different, surprising - future together with you!

With Best Regards,

Frank Schloeder
Managing Director, Häfele South Asia



THE PATH OF HÄFELE THAT TRANSLATED INTO SYMBOLS

For the 100-year anniversary of Häfele, we have expressed two things: The pride in the successful path that the company has taken up to today, and optimism that the path to the future will be just as successful because we have the courage to continuously reinvent ourselves. This is why the anniversary design is based on the roots of the company and is at the same time open and flexible. A modern forward-looking code that gives our ambitions a visual expression



MAXIMIZING THE VALUE OF SPACE. **TOGETHER.**

In conjunction with its 100-year anniversary celebrations this year, that kicked off at Interzum 2023, Hafele unveiled a new purpose line “**Maximizing the value of Space. Together.**”, which resonates strongly with us. We aim to strengthen our brand position in South Asia by emphasizing on the meaning of this purpose line, i.e. Hafele strives to provide the best of the best (**maximizing**) benefits (**value**) through its versatile solutions and services for different living and working spaces ranging from hotels, offices, institutes and homes as well as different interior applications like kitchens, living rooms & bedroom furniture, doors and interior partitions, wardrobes as well as furniture and room lighting. And this we strive to achieve in partnership (**together**) with all entities within our ecosystem from our suppliers, partners (Industry and Project), channels (distributors, dealers and franchisees), influencers (architects, designers, contractors and carpenters) right up to the final beneficiary i.e., our end customer.

In short, with our new purpose line we aim to co-create an environment for our endearing customers where they can enjoy the multiplied benefits of their living and working spaces.

Häfele Worldwide



With its origin in 1923 in a small town named 'Nagold' from the Swabian region of Germany that nurses a passion for hardware technology, it is no surprise that Häfele has lived up to its roots through a successful presence in the architectural and furniture hardware industry for over 10 decades now. Today, Häfele's worldwide penetration includes 38 subsidiaries across Europe, America, Asia, Australia and New Zealand. With these subsidiaries and numerous other sales organisations, Häfele operates in over 150 countries. The Häfele headquarters, 4 manufacturing units and 10 sales offices are located within Germany; while 1 manufacturing unit is located at Budapest, Hungary. The company also owns one of the largest and most sophisticated warehouses in its home country. The Häfele worldwide workforce is empowered by a base of over 8100 employees.

The group services over 150,000 customers across the globe through its extensive range of hardware products and a comprehensive logistics system. In addition to this, Häfele also provides consultative services to its customers, educating and advising them about buying the correct hardware as per their requirements. With this level of market penetration and ability to handle worldwide demand, it comes as no surprise that the company is an authority in the segment of home interior solutions; what is pleasantly surprising, though, is that in spite of its size, Häfele still remains a family owned and run business with a unique, friendly and value-centric work culture which is strongly followed among all its subsidiaries.

Häfele India

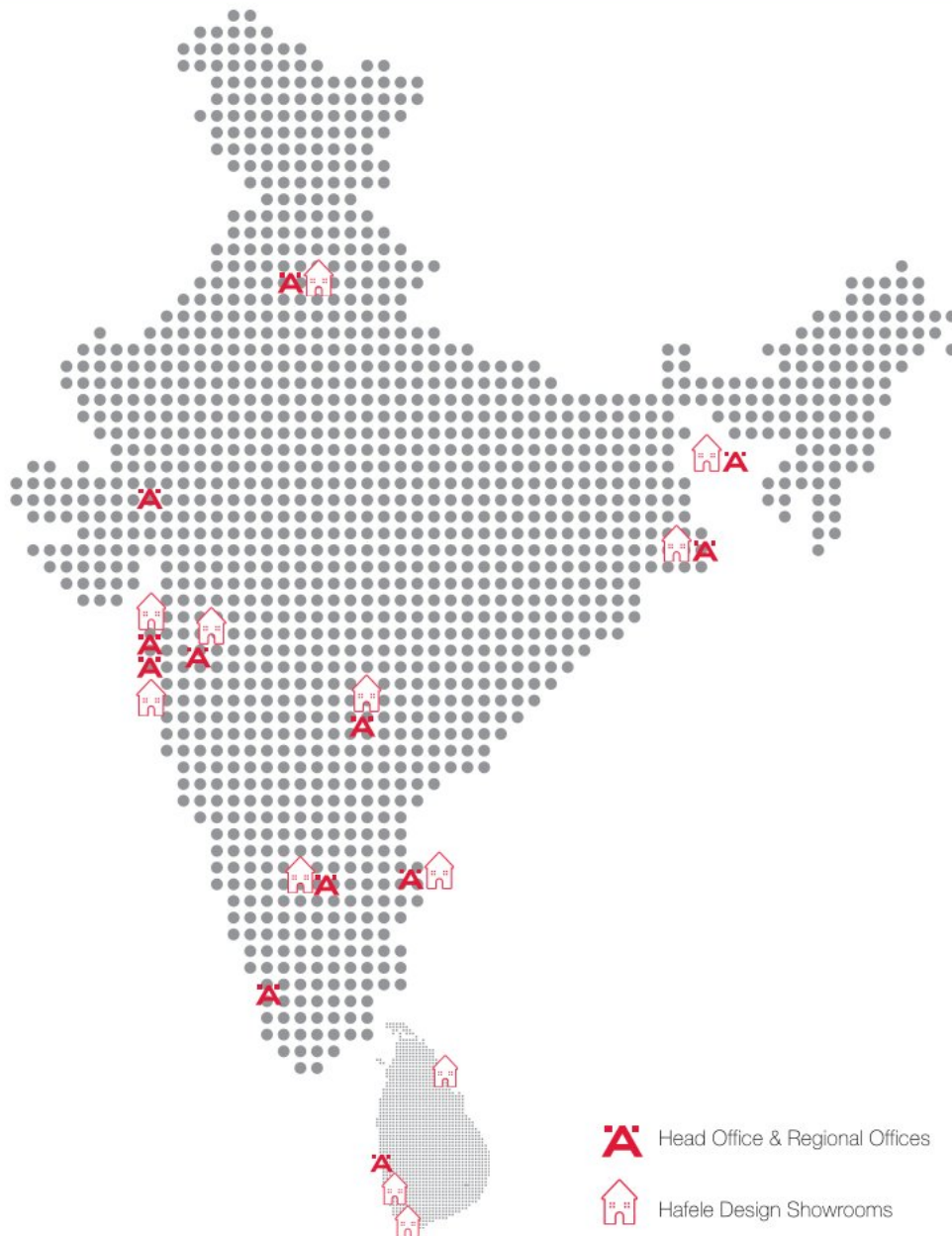

Häfele India is a wholly-owned subsidiary of the Häfele Global network and has been operating in India since 2003. The ability of the company to understand the diverse Indian market has made it an authority in the field of architectural hardware, furniture and kitchen fittings and accessories. The company also has a strong presence in synergized product categories namely Home Appliances, Interior Lighting, Water Solutions and Surfaces catering to the focused demand from these industries.

The subsidiary has a strong nation-wide presence with offices in Mumbai, Pune, Ahmedabad, Bangalore, Chennai, Hyderabad, Cochin, Delhi and Kolkata. It has full-scale operations in Sri Lanka and Bangladesh with Regional offices and Design Showrooms in both the countries; and has also spread its operations to other regions of South Asia including Nepal, Bhutan and Maldives.

Häfele's design showrooms are hubs of international home interior trends and cutting-edge designs presented in a world-class environment, where customers can see home solutions in their inherent applications. These showrooms function as a one-stop-shop for all home interior and improvement needs - from providing in-depth technical advice to kitchen and wardrobe designing services through a team of experts stationed at the showroom.

Häfele India services its customers with a base of 1500 employees, a well-networked Franchise base of over 180 Partners along with over 500+ direct dealers and 90+ distributors who in turn cater to over 12000+ sub dealers. The subsidiary has a sophisticated Logistics centre in Mumbai along with distribution centres in Delhi, Bangalore, Kolkata and Colombo respectively.



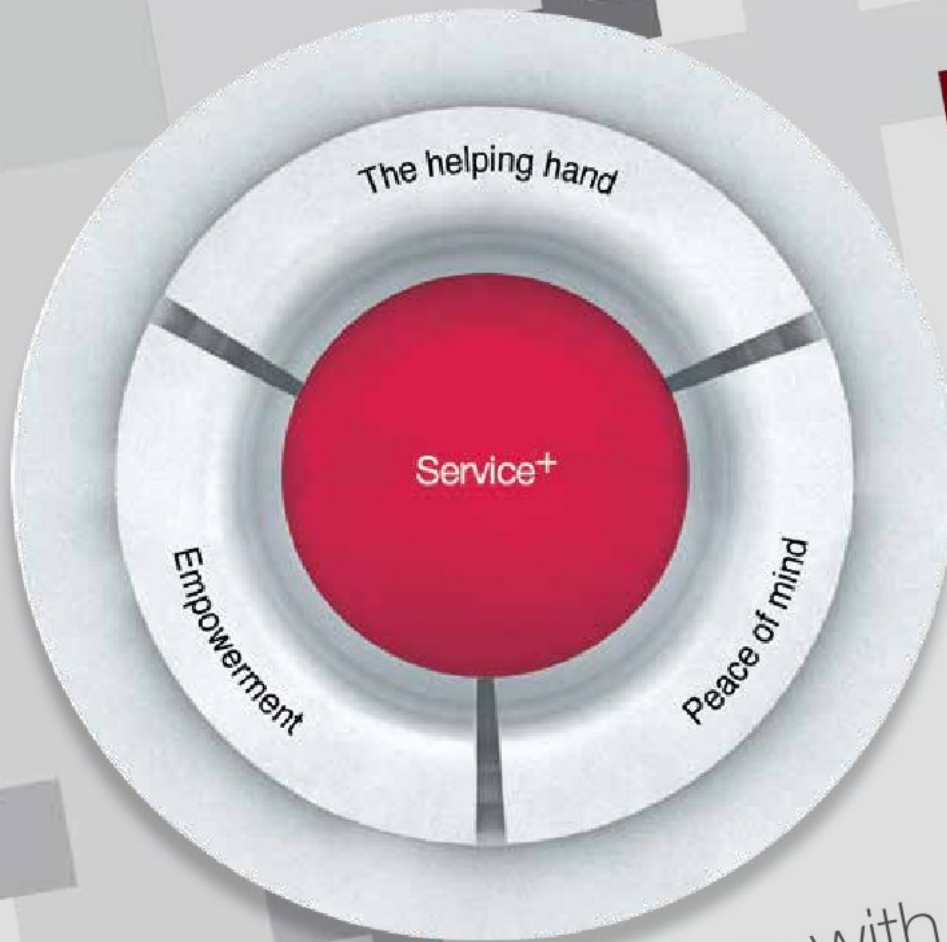

Experience More with **Service+**

Our customers' working environment is becoming increasingly complex and their market is becoming ever more demanding. This drives our motivation to do everything in our power to help our customers be successful. And to demonstrate that Häfele is the right partner in these challenging times, we want to accompany our customers throughout their entire business process and give them added strength in every phase of their business. We don't just want to sell our products, we also want to provide the highest level of service.

We have now divided our services into two categories: **Standard Services** which we provide to our customers as a matter of course when they choose our products. For example, a high availability of our goods and punctual delivery. And then there is Service+ which constitutes of services that give our customers considerable added value in terms of building expertise, increasing productivity or providing individual customised solutions. These services require a considerable amount of time and effort to develop and implement and are designed to enable our customers to regard them as worthwhile investments.

The aim is to create solid long-term foundations for our comprehensive service promise and to make Häfele an indispensable partner for our customers. The focus here lies not so much on us and on what we do – but rather, on the benefits derived by our customers. We want to **empower** them with opportunities to develop and expand their skills – both as masters of their trade and as entrepreneurs. We want to support them in the planning and realisation of their projects and relieve them of as much work as possible, thereby providing them with a **helping hand** to use their most valuable resource – time – as efficiently as possible. And we aim to give our customers **peace of mind** and the assurance that even after the end of a successful project completion, we will continue to be there for them as a reliable partner, shouldering responsibility.



The Pillars of **Service+**

In order to support you as comprehensively as possible, we have assigned the Plus Services to individual stages of your work process in a total of four themed pillars. We start with the transfer of knowledge and accompany you via planning and production to installation and maintenance.



Empowering customers with
Service+ Knowledge

Includes service offerings that provide inspiration and expertise to our customers about the Häfele product range. Through these, we enable our customers to use Häfele products profitably and at the same time remain at the cutting edge of technological development. One example of this is the Häfele Academy, which imparts knowledge about complex products and new technologies to our customers via seminars and trainings.

Providing a helping hand to customers with
Service+ Planning & Customised

Includes service offerings like space, design planning and customisations that make life easier for our customers and support their design vision. An example of this is Häfele's Lighting Design Service which helps our customers curate a lighting plan, following a customised approach, that enhances and brings out the true functionality of the interior space as per requirement.



Lending a "Peace-of-mind" experience through
Service+ Assist

Includes service offerings that provide support and assistance to our customers, whether digitally or on site. An example of this is the complete assembly and installation service for more complex and maintenance-intensive products done by our Meister certified and trained technicians.

Meister Service



Bought products from Häfele and got questions about how to use them correctly? Do you require technical support? Our competent technicians would be pleased to help you out with the help of Meister Service.

Meister Service offers complete installation of key hardware products from Häfele, by 'Meister Certified' and trained service technicians from the company directly, at a nominal service charge. This service is available for select products from categories like Kitchen Solutions, Sliding Solutions, Door Hardware, Furniture Fittings and Lighting Solutions.

Key benefits of this initiative:

- Accurate installation of products as per standards and specifications
- Optimum functionality through accurate installations
- Less hassles of product replacements
- A peace-of-mind experience for customers using Häfele products



To learn more about Meister Service please contact our team by scanning this QR code or call us at +91 1800 266 6667



The A to Z of perfect planning

With this catalogue Häfele, assists you with the planning of your kitchen. It is designed to provide you with inspiration as well as an overview of the important considerations to be taken in to account while planning a kitchen.

Häfele, the world renowned kitchen specialist offers hardware fittings that help you design your kitchen the way you dreamt of it. We provide you with options to pick and choose hardware that maximizes the functionality and at the same time is in line with the aesthetics of your kitchen.

Functionality is the soul of every kitchen. Without it, the kitchen is nothing more than an assembly of good looking cabinets. Our constant endeavor is to make your kitchen more functional, ergonomically and aesthetically more appealing, so that every minute of your presence in the kitchen is a joyful experience.

The Kitchen Selector gives you an exact idea about our products and helps you decide the products that would be best suited for your kitchen's design from a wide variety of options available, making it look more elegant.

To make your entire experience all the more enriching, Häfele offers a 360° service. We guide you right from the initial stage, i.e., in selecting the different products for your kitchen (using the Kitchen Selector), to designing your kitchen, and after selection once you have placed the order with our dealer, seeing to it that the products are delivered at the earliest.

Our service doesn't stop here, we have now introduced installation services under the "Meister Service" initiative where our technicians can install these products for you flawlessly. Last but not the least, we also provide after sales services to ensure that you have a smooth and hassle free kitchen at your perusal. Our 360° approach enables you to have your dream kitchen exactly the way you want it, and with the least bit of effort required from your side.

CONTENTS

1. Drawers

PAGE

16-46

2. Skido Kitchen Mats

PAGE

47-50

3. Drawer Organisers

PAGE

51-62

4. Flap & Lid Stays Lift Up Systems

PAGE

63-97

5. Hinges

PAGE

98-123

6. Corner Units

PAGE

124-132

7. Tall Units

PAGE

133-145

8. Roller Shutters

PAGE

146-148

9. Waste Bins

PAGE

149-161

10. Aluminium Profiles

PAGE

162-209**11. Kitchen Handles**

PAGE

210-222**12. Kitchen Accessories**

PAGE

223-264**13. Plinth Fittings & Accessories**

PAGE

265-271**14. Lighting Solutions**

PAGE

272-324**15. Kitchen Sinks & Faucets**

PAGE

325-371**16. Caesarstone**

PAGE

372-380**17. Terra**

PAGE

381-389**18. Dekton**

PAGE

390-398

DRAWERS



MatrixBox Premium



Drawer side colours



The MatrixBox Premium drawer system, manufactured at Häfele's own factory in Kenzingen, Germany, operates smoothly, opens swiftly and closes with precision.

This premium drawer system features simple assembly and easy adjustment as well as unrivalled design and flexibility in application. It is suitable for installation in kitchens, bedrooms, bathrooms and home offices, as

well as commercial and industrial environments. MatrixBox Premium offers the widest range of accessories, comes equipped with Soft-Close as well as Push-to-Open Soft-Close runner system functionalities in weight carrying capacities of 35 kg and 50 kg and is available in Metallic Anthracite, Metallic Silver and White finishes. The nominal length of the drawer starts from 300 mm & goes up to 550 mm.



EASY ASSEMBLY

Ease in preparation - The base and rear panels of the MatrixBox Premium drawers are required to be of the same width.

Ease of installation - The pre-assembled rear panel fixing bracket on the drawer sides can directly be screwed to the rear panel. Furthermore, the assembly/disassembly of the front can be carried out tool-free.



EXTENSIVE RANGE

The MatrixBox Premium drawer systems can adapt to your individual requirements thanks to their modular system structure, buildable configurations and large range of matching accessories.



VARIABLE USAGE

Due to its load bearing capacity (35/50 kg), modularity and universal design aesthetics, the range can be implemented in any area, be it the kitchen, bathroom, living room, office or store.



VERSATILE DESIGN

Thanks to the 3 colour choices, individual side panels, internal drawer panels and the push-to-open soft-close option for handle-free furniture designs, this range provides you with freedom to adapt your drawer designs to flawlessly complement the overall interior theme.



GENEROUS SPACE

The MatrixBox Premium drawers are built to provide more usable space due to the straight 90° inner wall of the drawer sides. The straight wall also provides greater stability to the items stored within while the full extension feature enables you to have a better overview of the drawer contents.



EXCELLENT PERFORMANCE

The drawer systems display optimised running and closing characteristics due to synchronized runners with fluid damper and cushioned end stop in the open position.



COMFORTABLE ADJUSTMENT

The height and side adjustments of the front panel can be carried out from the top of the drawer sides, this helps carry out adjustments easily even in confined spaces. The front panel can be seamlessly readjusted even with items stored in the drawer.



GERMAN QUALITY

MatrixBox Premium drawer systems are developed and produced at Häfele's own factory in Kenzingen, Germany. Having cycle tested for 100,000 times, these systems meet and even exceed the LGA certification requirements. They additionally come with the best operating characteristics, inherent elegant motions and smooth closing in accordance with the certified Häfele quality standards.

MatrixBox Premium - Standard Drawer

Standard 92 mm Drawer Set

- **Runner technology:** With integrated Soft-Close or with push-to-open Soft-Close
- **Material:** Drawer sides and runners: Steel
- **Finish:** Drawer sides: Metallic anthracite, Metallic silver and white



ORDERING INFORMATION

Sets

Nominal Length (NL) (mm)	Soft-Close			With Push-to-Open Soft-Close		
	Metallic Silver	Metallic Anthracite	White	Metallic Silver	Metallic Anthracite	White
Load Bearing Capacity : 35 Kg., Drawer Side Height: 92 mm						
300	513.24.901	513.24.301	513.24.701	-	-	-
350	513.24.902	513.24.302	513.24.702	-	-	-
400	513.24.903	513.24.303	513.24.703	-	-	-
450	513.24.904	513.24.304	513.24.704	513.24.924	513.24.324	513.24.724
500	513.24.905	513.24.306	513.24.705	513.24.925	513.24.325	513.24.725
550	513.24.906	513.24.305	513.24.706	513.24.926	513.24.326	513.24.726
Load Bearing Capacity : 50 Kg., Drawer Side Height: 92 mm						
500	513.24.915	513.24.315	513.24.715	513.24.935	513.24.335	513.24.735
550	513.24.916	513.24.316	513.24.716	513.24.936	513.24.336	513.24.736

MatrixBox Premium - Standard Drawer With Rectangular Railings

Standard 92 mm Drawer Set with Rectangular Side Railings



- **Runner technology:** With integrated Soft-Close or with push-to-open Soft-Close
- **Material:** Drawer sides and runners: Steel, Railing holder: Plastic
- **Finish:** Drawer sides and railing: Metallic anthracite, Metallic silver and white



ORDERING INFORMATION

G1: Rectangular Side Railings			
Nominal Length (mm)	Colour		
	Metallic Silver	Metallic Anthracite	White
300	551.60.941	551.60.341	551.60.741
350	551.60.942	551.60.342	551.60.742
400	551.60.943	551.60.343	551.60.743
450	551.60.944	551.60.344	551.60.744
500	551.60.945	551.60.345	551.60.745
550	551.60.946	551.60.346	551.60.746

Unit: 1 Pair

MatrixBox Premium - Standard Drawer With Round Railings

Standard 92 mm Drawer Set with Round Side Railings

- **Runner technology:** With integrated Soft-Close or with push-to-open Soft-Close
- **Material:** Drawer sides and runners: Steel, Railing holder: Plastic
- **Finish:** Drawer sides and railing: Metallic anthracite, Metallic silver and white



ORDERING INFORMATION

G2: Round Side Railings			
Nominal Length (mm)	Colour		
	Metallic Silver	Metallic Anthracite	White
450	553.58.994	553.58.394	553.58.794
500	553.58.995	553.58.395	553.58.795
550	553.58.996	553.58.396	553.58.796

Unit: 1 Pair

MatrixBox Premium - Standard Drawer With Side Panels

Standard 92 mm Drawer Set with Height Extension Side Panels



- **Runner technology:** With integrated Soft-Close or with push-to-open Soft-Close
- **Material:** Drawer sides and runners: Steel, Railing holder: Plastic
- **Finish:** Drawer sides, railings and height extension panels: Metallic anthracite, Metallic silver and white



ORDERING INFORMATION

G2: Round Side Railings			
Nominal Length (mm)	Colour		
	Metallic Silver	Metallic Anthracite	White
450	553.58.994	553.58.394	553.58.794
500	553.58.995	553.58.395	553.58.795
550	553.58.996	553.58.396	553.58.796

Unit: 1 Pair

J: Height Extension Side Panels			
Nominal Length (mm)	Colour		
	Metallic Silver	Metallic Anthracite	White
450	551.60.914	551.60.314	551.60.614
500	551.60.915	551.60.315	551.60.615
550	551.60.916	551.60.316	551.60.616

Unit: 1 Pair

MatrixBox Premium - Standard Drawer With Lateral Inserts

Standard 92 mm Drawer Set with Lateral Inserts

- **Runner technology:** With integrated Soft-Close or with push-to-open Soft-Close
- **Material:** Drawer sides and runners: Steel, Lateral décor insert holder: Plastic, die-cast Steel
- **Finish:** Drawer sides and lateral décor insert holder: Powder coated, Cabinet runner: Zinc plated



ORDERING INFORMATION

K: Lateral Décor Insert Holder Set		
Colour		
Metallic Silver	Metallic Anthracite	White
551.60.599	551.60.999	553.60.699

Unit: 1 Set

MatrixBox Premium - Inner Drawer With Front Panel

92 mm Inner Drawer Set with Front Panel



- **Runner technology:** With integrated Soft-Close or with push-to-open Soft-Close
- **Material:** Drawer sides and runners: Steel, Front panel: Aluminium, Inner drawer front fixing bracket: Plastic
- **Finish:** Drawer sides and Front panel: Metallic anthracite, Metallic silver and white



Easy Assembly Comfortable Adjustment Extensive Range Versatile Design Variable Usage Excellent Performance Generous Space German Quality

ORDERING INFORMATION

Inner Drawer Solid Front Kit - 102 mm			
Upto Cabinet Width (mm)	Colour		
	Metallic Silver	Metallic Anthracite	White
600*	513.70.912	513.70.312	513.70.712
1200**	513.70.918	513.70.318	513.70.718

*Consists of: Inner Drawer Front Panel (102 mm) x 1 Piece, Inner Drawer Front Fixing Brackets (102 mm) x 1 Pair, Front Stabilisation Clip x 1 Piece

**Consists of: Inner Drawer Front Panel (102 mm) x 1 Piece, Inner Drawer Front Fixing Brackets (102 mm) x 1 Pair, Front Stabilisation Clip x 3 Pieces

MatrixBox Premium - Inner Drawer With Front Panel + Rectangular Railings

92 mm Inner Drawer Set with Front Panel and Rectangular Side Railings

- **Runner technology:** With integrated Soft-Close or with push-to-open Soft-Close
- **Material:** Drawer sides, runners and railings: Steel, Front panel: Aluminium, Inner drawer front fixing bracket: Plastic
- **Finish:** Drawer sides, side railings and front panel: Metallic anthracite, Metallic silver and white



ORDERING INFORMATION

Inner Drawer Solid Front Kit - 189 mm			
Drawer Depth (mm)	Colour		
	Metallic Silver	Metallic Anthracite	White
Upto 600 mm Cabinet Width*			
450	513.42.964	513.42.364	513.42.764
500	513.42.965	513.42.365	513.42.765
550	513.42.966	513.42.366	513.42.766
Upto 1200 mm Cabinet Width**			
450	513.42.984	513.42.384	513.42.784
500	513.42.985	513.42.385	513.42.785
550	513.42.986	513.42.386	513.42.786
*Consists of: Inner Drawer Front Panel (189 mm) x 1 Piece, Inner Drawer Front Fixing Brackets (189 mm) x 1 Pair, Rectangular Side Railings x 1 Pair, Back Adapters x 1 Pair and Front Stabilisation Clip x 1 Piece			
**Consists of: Inner Drawer Front Panel (189 mm) x 1 Piece, Inner Drawer Front Fixing Brackets (189 mm) x 1 Pair, Rectangular Side Railings x 1 Pair, Back Adapters x 1 Pair and Front Stabilisation Clip x 3 Pieces			

MatrixBox Premium - Inner Drawer With Front Panel + Rectangular Railing + Lateral Inserts

92 mm Inner Drawer Set with Front Panel, Rectangular Side Railings and Rear Lateral Décor Insert Holders



- **Runner technology:** With integrated Soft-Close or with push-to-open Soft-Close
- **Material:** Drawer sides, runners and railings: Steel, Front panel: Aluminium, Inner drawer front fixing bracket and rear lateral décor insert holder: Plastic
- **Finish:** Drawer sides, side railings, front panel and rear lateral decor insert holder: Metallic anthracite, Metallic silver and white

ORDERING INFORMATION

Inner Drawer Solid Front Kit - 189 mm			
Drawer Depth (mm)	Colour		
	Metallic Silver	Metallic Anthracite	White
Upto 600 mm Cabinet Width*			
450	513.42.964	513.42.364	513.42.764
500	513.42.965	513.42.365	513.42.765
550	513.42.966	513.42.366	513.42.766
Upto 1200 mm Cabinet Width**			
450	513.42.984	513.42.384	513.42.784
500	513.42.985	513.42.385	513.42.785
550	513.42.986	513.42.386	513.42.786
*Consists of: Inner Drawer Front Panel (189 mm) x 1 Piece, Inner Drawer Front Fixing Brackets (189 mm) x 1 Pair, Rectangular Side Railings x 1 Pair, Back Adapters x 1 Pair and Front Stabilisation Clip x 1 Piece			
**Consists of: Inner Drawer Front Panel (189 mm) x 1 Piece, Inner Drawer Front Fixing Brackets (189 mm) x 1 Pair, Rectangular Side Railings x 1 Pair, Back Adapters x 1 Pair and Front Stabilisation Clips x 3 Pieces			
O: Rear Lateral Décor Insert Holder			
Colour			Article No.
Metallic Silver			513.72.999
Metallic Anthracite			513.72.399
Solid White			513.72.799

Unit: 1 Pair

MatrixBox Premium - Inner Drawer With Front Insert + Rectangular Railings

92 mm Inner Drawer Set for Front Décor Insert Holder Kit and Rectangular Side Railings

- Runner technology:** With integrated Soft-Close or with push-to-open Soft-Close
- Material:** Drawer sides, runners and railings: Steel,
Front panel profile: Aluminium,
Front décor insert holder kit: Plastic
- Finish:** Drawer sides, side railings and front panel profile: Metallic anthracite,
Metallic silver and white



ORDERING INFORMATION

Inner Drawer Décor Front Kit (189 mm)*			
Drawer Depth (mm)	Colour		
	Metallic Silver	Metallic Anthracite	White
Upto 600 mm Cabinet Width			
450	513.52.365	513.52.366	513.52.364
500	513.52.765	513.52.766	513.52.764
550	513.52.965	513.52.966	513.52.964
Upto 1200 mm Cabinet Width			
450	513.52.385	513.52.386	513.52.384
500	513.52.785	513.52.786	513.52.784
550	513.52.985	513.52.986	513.52.984

*Consists of: Front Panel Profile x 1 Piece, Front Décor Insert Holder Set x 1, Rectangular Side Railings x 1 Pair and Back Adapters x 1 Pair

MatrixBox Premium - Inner Drawer With Front Insert + Rectangular Railings + Lateral Inserts

92 mm Inner Drawer Set with Front Décor Insert Holder Kit, Rectangular Side Railings and Rear Lateral Décor Insert Holders



- **Runner technology:** With integrated Soft-Close or with push-to-open Soft-Close
- **Material:** Drawer Sides, runners and railings: Steel, Front panel profile: Aluminium, Front décor insert holder kit and rear lateral décor insert holder: Plastic
- **Finish:** Drawer sides, side railings, front panel profile and rear lateral decor insert holder: Metallic anthracite, Metallic silver and white



ORDERING INFORMATION

Inner Drawer Décor Front Kit (189 mm)*			
Drawer Depth (mm)	Colour		
	Metallic Silver	Metallic Anthracite	White
Upto 600 mm Cabinet Width			
450	513.52.365	513.52.366	513.52.364
500	513.52.765	513.52.766	513.52.764
550	513.52.965	513.52.966	513.52.964
Upto 1200 mm Cabinet Width			
450	513.52.385	513.52.386	513.52.384
500	513.52.785	513.52.786	513.52.784
550	513.52.985	513.52.986	513.52.984

*Consists of: Front Panel Profile x 1 Piece, Front Décor Insert Holder Set x 1, Rectangular Side Railings x 1 Pair and Back Adapters x 1 Pair

O: Rear Lateral Décor Insert Holder	
Colour	Article No.
Metallic Silver	513.72.999
Metallic Anthracite	513.72.399
Solid White	513.72.799

Unit: 1 Pair

MatrixBox Premium - Standard Drawer For Under-Sink Unit

92 mm Standard Drawer Under Sink Pull-out, Runner Nominal Length = 500 mm

- **Runner technology:** With integrated Soft-Close or with push-to-open Soft-Close
- **Material:** Drawer sides and runners: Steel
- **Finish:** Drawer sides, sink cut-out set and railings: Metallic anthracite, Metallic silver and white



ORDERING INFORMATION

Under Sink Pull-out Set*	
Colour	Article No.
Metallic Silver	513.65.905
Metallic Anthracite	513.65.305
White	513.65.705

*Consists of: Sink Cut-out Set x 1, Drawer Sides (NL = 350 mm) x 1 Pair and Cover Caps x 1 Pair

MatrixBox Premium - Side Pull-Out

Standard 92 mm Narrow Side Pull-out with Rectangular / Round Side Railings



- **Runner technology:** With integrated Soft-Close
- **Material:** Drawer sides and runners: Steel, Railing holder: Plastic
- **Finish:** Drawer sides and railing: Metallic anthracite, Metallic silver and white



Easy Assembly Comfortable Adjustment Extensive Range Versatile Design Variable Usage Excellent Performance Generous Space German Quality

ORDERING INFORMATION

Sets

MatrixBox Premium Side Pull-out Set*			
Drawer Depth (mm)	Colour		
	Metallic Silver	Metallic Anthracite	White
With Rectangular Side Railings			
450	513.07.375	513.09.374	513.07.975
500	513.09.974	513.09.375	513.09.774
550	513.09.975	513.09.376	513.09.775
With Round Side Railings			
450	513.09.976	513.07.374	513.09.776
500	513.07.974	513.07.376	513.07.774
550	513.07.976	513.07.377	513.07.775

*Consists of: Cabinet Runner with Soft Close x 1 Pair, Drawer Sides x 2 Pairs, Front Fixing Brackets x 2 Pairs, Cover Caps x 2 Pairs and Rectangular / Round Side Railings x 1 Pair

MatrixBox Premium - Internal Divider System

Rectangular Cross Rail and Connectors

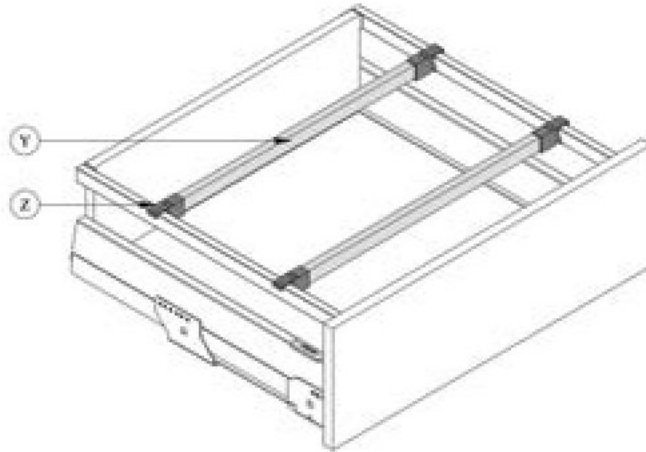

Y	Rectangular Cross Rail
Z	Rectangular Cross Rail Connector

ORDERING INFORMATION

Rectangular Cross Rail and Connector Kit			
Cabinet Width (mm)	Colour		
	Metallic Silver	Metallic Anthracite	White
Upto 600 mm*	513.70.967	513.70.367	513.70.767
Upto 1200 mm**	513.70.968	513.70.368	513.70.768

*Consists of: Rectangular Cross Rail x 1 and Rectangular Cross Rail Connector x 4
 **Consists of: Rectangular Cross Rail x 2 and Rectangular Cross Rail Connector x 4

MatrixBox Slim



The MatrixBox Slim drawer system by Häfele comes with a sophisticated slim design and operates smoothly, opens swiftly and closes with precision.

This Slim drawer system with 13mm thin drawer sides, features simple assembly as well as unrivalled design and flexibility in application. It is suitable for installation in kitchens, bedrooms and bathrooms. MatrixBox Slim comes

with 3 height options, 2 side design options (Solid & Décor) and 2 weight carrying capacities (40 & 60 kg); giving you the widest choice for a host of applications. With an integrated Soft-Close and a Synchronized Runner Technology, the movement of these drawers is smooth, stable and precise. The attractive Graphite Grey Finish brings sophistication and elegance to your home design.

MatrixBox Slim - H1 Standard Drawers

Standard H1 (88mm) Drawer Set

- **Material:** Steel
- **Finish:** Graphite grey
- **Type of pull-out:** Full extension with integrated Soft-Close
- **Weight carrying capacities:** 40 kg



40 kg Systems

ORDERING INFORMATION

Nominal Length		Article No.
1	350 mm	554.00.802
2	400 mm	554.00.803
3	450 mm	554.00.804
4	500 mm	554.00.805
5	550 mm	554.00.806



MatrixBox Slim - H2 Standard Drawers

Standard H2 (172mm) Drawer Set with Solid Drawer Side

- **Material:** Steel
- **Finish:** Graphite grey
- **Drawer side:** Solid
- **Type of pull-out:** Full extension with integrated Soft-Close
- **Weight carrying capacities:** 40 kg & 60 kg

ORDERING INFORMATION

Nominal Length		40 kg Systems	60 kg Systems
1	350 mm	554.01.802	-
2	400 mm	554.01.803	-
3	450 mm	554.01.804	-
4	500 mm	554.01.805	554.01.905
5	550 mm	554.01.806	554.01.906

MatrixBox Slim - H2 Standard Drawers

Standard H2 (172mm) Drawer Set with Décor Drawer Side



- **Material:** Steel
- **Finish:** Graphite grey
- **Drawer side:** Décor
- **Type of pull-out:** Full extension with integrated Soft-Close
- **Weight carrying capacities:** 40 kg



Easy Assembly Extensive Range Versatile Design Variable Usage Excellent Performance German Quality

40 kg Systems

ORDERING INFORMATION

Nominal Length		Article No.
1	500 mm	554.01.845
2	550 mm	554.01.846

MatrixBox Slim - H3 Standard Drawers

Standard H3 (238mm) Drawer Set

- **Material:** Steel
- **Finish:** Graphite grey
- **Type of pull-out:** Full extension with integrated Soft-Close
- **Weight carrying capacities:** 40 kg & 60 kg



ORDERING INFORMATION

Nominal Length		40 kg Systems	60 kg Systems
1	500 mm	554.01.825	554.01.925
2	550 mm	554.01.826	554.01.926

MatrixBox Slim - Inner Drawers

H1 (88 mm) Inner Drawer Solid Front Set



- **Material:** Aluminium
- **Finish:** Graphite grey
- **Type of pull-out:** Solid

ORDERING INFORMATION

Cabinet Width		Article No.
1	600 mm	552.19.590
2	1200 mm	552.19.591

MatrixBox Slim Sets – Pick H1 Standard drawer configuration sets that best suit your requirements.

+ Choose the Solid Front Set from the table above as per the Cabinet Width

H2 (172 mm) Inner Drawer Solid Front Set

- **Material:** Aluminium
- **Finish:** Graphite grey
- **Type of pull-out:** Solid + Square Cross Rail



ORDERING INFORMATION

Cabinet Width		Article No.
1	600 mm	552.19.570
2	1200 mm	552.19.571

MatrixBox Slim Sets – Pick H2 Standard drawer configuration sets that best suit your requirements.

+ Choose the Solid Front Set from the table above as per the Cabinet Width

H2 (172mm) Inner Drawer Décor Front Set

- **Material:** Aluminium
- **Finish:** Graphite grey
- **Type of pull-out:** Décor

**ORDERING INFORMATION**





Cabinet Width		Article No.
1	600 mm	552.19.596
2	1200 mm	552.19.597

MatrixBox Slim Sets – Pick H2 Standard drawer configuration sets that best suit your requirements.

+ Choose the Décor Front Set from the table above as per the Cabinet Width

MatrixBox Slim - Under Sink Unit



- 
Easy
Assembly
- 
Versatile
Design
- 
Variable
Usage
- 
Excellent
Performance
- 
German
Quality

- **Material:** Plastic
- **Finish:** Dark grey
- **Suitable for:** Drawers with 16mm base and rear panel

- Ideal for maximum utilization of the under-sink space
- This under sink organization system consists of a unique H-shaped frame to conceal sink cut-out and 3 storage trays
- Storage trays are easy to clean and impact resistant. These trays come in 3 different sizes that can be configured to suit individual's requirement. They can either be secured in place with fixing rail or can be used as freestanding units
- Maximum cut-out width can be extended to 835mm using the connector and transverse profile which are included in the package

Components

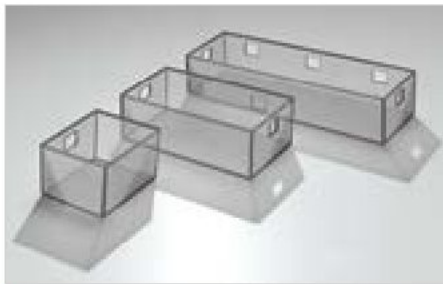

1 Storage Trays



2 Basic Module

ORDERING INFORMATION

Description	Article No.
1 Basic Module – H-frame, 2 transverse profiles with connector, fixing rail for trays and rear brackets	556.23.668
2 Storage trays	556.23.428

Wicker Basket

Wicker basket pull-outs for kitchens, defines the age old rule that governs traditional kitchen shelves for storage. It is highly functional and aesthetically appealing, giving your kitchen a new look and feel.

Features:

- These range of wicker baskets are light yet sturdy and durable.
- Help vegetables to stay fresh for days
- Made from willows of natural brown color, it is hand woven into the clear lacquered beech frame. It is an excellent storage solution for environmentally conscious people.
- It is easy to maintain and comes as a ready to install unit.
- Available in two different dimensions these adorable wicker baskets from Häfele make perfect stylish storage for kitchen.



1 Wicker basket (With handle)



Wooden channels for Wicker basket (22 x 500 mm)

ORDERING INFORMATION

Product Description	Dimensions (WxDxH) mm	Article No.
1 Wicker basket for 450 mm cabinet (With Handle)	370 x 500 x 210	540.57.042
2 Wicker basket for cabinet width 600 mm (With Handle)	520 x 500 x 210	540.57.045

VS SUB Slim



Features:

- **Width:** 150 mm
- **3 versions:** 2 storage racks, towel holder & baking tray storage
- **Load capacity:** Max 6kg per shelf
- **Installation depth:** Min. 495 mm
- **Installation height:** Min. 530 mm
- Tool-free assembly on to the runner
- 3D front adjustment enables convenient and easy adjustment of the front
- Pull out with soft closing
- Integrated soft closing



1 VS Sub Slim Spice and Oil Bottle Pull Out

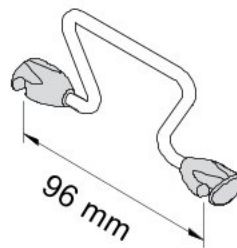

2 VS Sub Slim Bottle Divider 96 mm



3 VS Sub Slim Towel & Detergent Pull Out

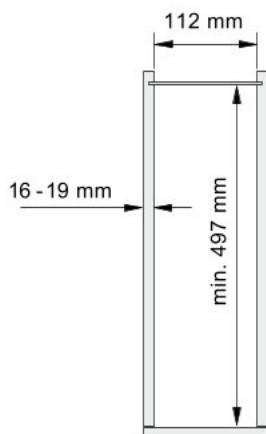

Cabinet dimension

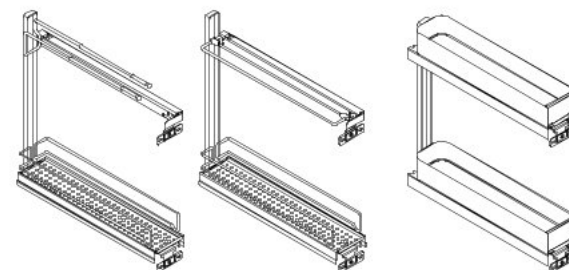

Product dimension

ORDERING INFORMATION

Product Description	Grey Powder Coated	Lava Grey
1 VS Sub Slim Spice and Oil Bottle Pull Out for 150 mm cabinet width	545.12.961	548.08.320
2 VS Sub Slim Bottle Divider 96 mm	545.12.991	
3 VS Sub Slim Towel & Detergent Pull Out for 150 mm cabinet width	545.12.911	548.08.340

VS SUB Side

Häfele introduces its popular side mounted storage with additional front stabilization and an adjustment device for wide fronts, including a functional element for a large variety of different set-ups. Integrated damping ensures quiet opening and shutting. Available in Premea grey, Artline chrome, Planero lava grey finish to enhance the aesthetic appeal.

Features:

- **Cabinet width:** 150mm, 300mm
- **Total load capacity:** 20 kg
- **Installation depth:** Min 495 mm
- **Installation height:** Min 485 mm
- 3D front adjustment
- Unhanded
- Individually height adjustable baskets
- Toolless front connection
- Integrated soft closing



VS SUB Side, Planero Lava Grey



ARTLINE basket



Premea basket

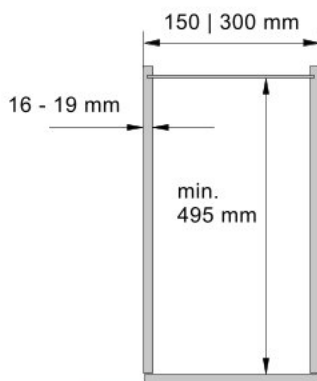

Cabinet dimension

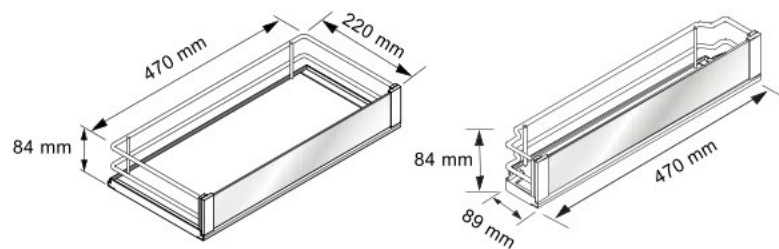

Product dimension

ORDERING INFORMATION

Product Description	Artline Chrome	Premea Grey	Planero Lava Grey
1 VS Sub Side for Cabinet Width 300 mm	546.38.234	546.38.964	546.38.494

Matrix UM



Häfele's in-house range of Matrix Undermount runners comes with an elegant motion technology that can suit a host of applications within kitchens, living room furniture, bed storage units, wardrobes and bathroom units.

Available in 4 weight-carrying capacities and a large range of nominal lengths, the Matrix Undermount runners can execute any required drawer design. The 40 and 60 kg runners come with a synchronized technology providing excellent motion and stability to the drawers. All runners come with an integrated soft-close mechanism that offers smooth and noiseless closing of the drawer units.



Matrix UM 40 & Matrix UM 60

- **Material:** Steel
- **Finish:** Zinc Plated
- **Type:** Full-extension with integrated Soft-close
- **Weight carrying capacities:** 40 & 60 kg
- Optimised running and closing characteristics due to synchronized runners
- 3D adjustment locking bracket.



ORDERING INFORMATION

Matrix Undermount Runners		40 kg	60 kg
Nominal Length		Article Number	
1	300 mm	433.09.501	-
2	350 mm	433.09.502	-
3	400 mm	433.09.503	-
4	450 mm	433.09.504	-
5	500 mm	433.09.505	433.09.515
6	550 mm	433.09.506	433.09.516
7	600 mm	433.09.507	433.09.517

Matrix UM 35



- **Material:** Steel
- **Finish:** Zinc plated
- **Type:** Full-extension with integrated Soft-close
- **Weight carrying capacities:** 35 kg
- 2D adjustment locking bracket

ORDERING INFORMATION

35 kg Matrix Undermount Runners		
Nominal Length		Article Number
1	300 mm	433.09.531
2	350 mm	433.09.532
3	400 mm	433.09.533
4	450 mm	433.09.534
5	500 mm	433.09.535
6	550 mm	433.09.536
7	600 mm	433.09.537

Matrix UM 25

- **Material:** Steel
- **Finish:** Zinc Plated
- **Type:** Partial-extension with integrated Soft-close
- **Weight carrying capacities:** 25 kg
- Height adjustment locking bracket



ORDERING INFORMATION

25 kg Matrix Undermount Runners		Article Number
Nominal Length		
1	300 mm	433.31.101
2	350 mm	433.31.102
3	400 mm	433.31.103
4	450 mm	433.31.104
5	500 mm	433.31.105

Drawer Runners



Ball Bearing Slides Full Extension, Side Mounted

Runners can be disengaged using release lever, with stay closed feature for holding in closed position.

- **Material:** Steel
- **Finish:** Zinc Galvanized and Black (25-40 kg)*, Bright Zinc Galvanized (40 kg soft close)
*(Except for 40 kg, Push to open is only available in Zinc Finish and not in Black)
- **Cycle testing:** 40,000 cycles
- **Salt test:** 48 hr
- **Available sizes:** 250 mm to 700 mm
- **Load bearing capacity:** 25 kg, 30 kg/pair, 40kg/pair (Soft close runners and push to open runners) and 45kg/pair



1 Ball Bearing Slides Side Mounted Full Extension: 25 kg



2 Ball Bearing Slides Side Mounted Full Extension: 30 kg



3 Soft Close Ball Bearing Runner: 40 kg



5 Ball Bearing Slides Side Mounted Full Extension: Push to open (40kg)



4 Ball Bearing Slides Side Mounted Full Extension: 45 kg

ORDERING INFORMATION

Sizes (mm)	1 Ball Bearing Slides Side Mounted Full Extension (25 kg)		2 Ball Bearing Slides Side Mounted Full Extension (30 kg)		3 Soft Close Ball Bearing Runner (40 kg)		4 Ball Bearing Slides Side Mounted Full Extension, Push to open (40kg)		5 Ball Bearing Slides Side Mounted Full Extension (45 kg)	
	Zinc Galvanised	Black	Zinc Galvanised	Black	Zinc Plated	Black	Zinc Galvanised	Zinc Galvanised	Black	
250	420.55.900	420.55.300	422.87.900	422.87.300	-	-	-	422.58.925	422.58.325	
300	420.55.901	420.55.301	422.87.901	422.87.301	432.02.191	432.02.131	422.02.061	422.58.930	422.58.330	
350	420.55.902	420.55.302	422.87.902	422.87.302	432.02.192	432.02.132	422.02.062	422.58.935	422.58.335	
400	420.55.903	420.55.303	422.87.903	422.87.303	432.02.193	432.02.133	422.02.063	422.58.940	422.58.340	
450	420.55.904	420.55.304	422.87.904	422.87.304	432.02.194	432.02.134	422.02.064	422.58.945	422.58.345	
500	420.55.904	420.55.305	422.87.905	422.87.305	432.02.195	432.02.135	422.02.065	422.58.950	422.58.350	
550	420.55.906	420.55.306	422.87.906	422.87.306	432.02.196	432.02.136	422.02.066	422.58.955	422.58.355	
600	-	-	-	-	432.02.197	432.02.137	422.02.067	422.58.960	422.58.360	
650	-	-	-	-	-	-	-	422.58.965	422.58.365	
700	-	-	-	-	-	-	-	422.58.970	422.58.370	

SKIDO KITCHEN MATS



Kitchen Drawer Mats



Häfele's Range of Non-Slip Kitchen Drawer Mats can be ordered in a variety of colours and textures and are a must have for designers of all spaces. These mats stand out on account of their easy adaptability to any surface providing enhanced order, cleanliness and comfort. The functional surface of these mats along with high resistance to slipping and sliding ensures that objects stay securely in place. When coupled with Häfele's Range of Cutlery inserts, they make a powerful organizational duo.



1 Skido Bubble, Alu Grey



2 Skido Flock, Anthracite

ORDERING INFORMATION

Product Description	Article No.	Unit
1 Skido Bubble, Alu Grey, 1550mm x 1.2mm (To be ordered in MTR) (1 Roll = 20 MTR)	547.97.539	MTR
2 Skido Flock, Anthracite, 500mm x 1440mm x 1.3mm	547.94.384	PC

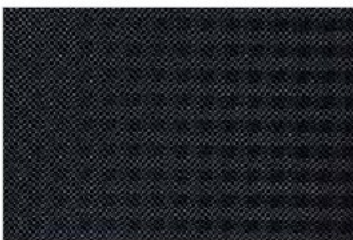

1 Skido Kristall, Black



2 Skido Canvas, Basalt Grey



3 Skido Tex, Stone Grey

ORDERING INFORMATION

Product Description	Article No.	Unit
1 Skido Kristall, Black, 500mm x 1440mm x 1.2mm	547.94.464	PC
2 Skido Canvas, Basalt Grey, 500mm x 1440mm x 1.2mm	547.94.674	PC
3 Skido Tex, Stone Grey, 500mm x 1440mm x 1.1mm	547.90.284	PC

Kitchen Drawer Mats

Each **Skido Line Drawer Mat** comes with a depth of 1440 mm and a width of 1000 mm. Considering the average external depth of a drawer is 500 mm, the mat can be laterally divided into 3 parts, each of 480 mm (denoted by the grey dotted lines).

Horizontally the mat can be cut into various combinations depending upon different drawer widths. In the example given below, you can see how one sheet of the Skido Line Drawer Mat is used for 5 drawers (no. of drawers depends on the drawer widths).

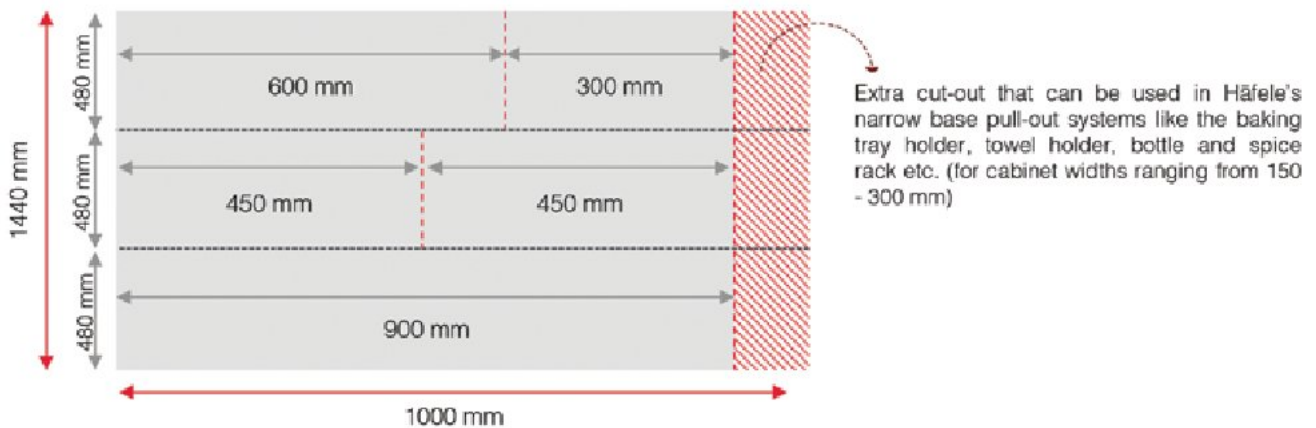

Similarly the **Skido Drawer Mats** come with a depth of 500 mm and a width of 1440 mm. Considering the average external depth of a drawer is 500 mm, the mat can be used for one or more drawers. For eg.

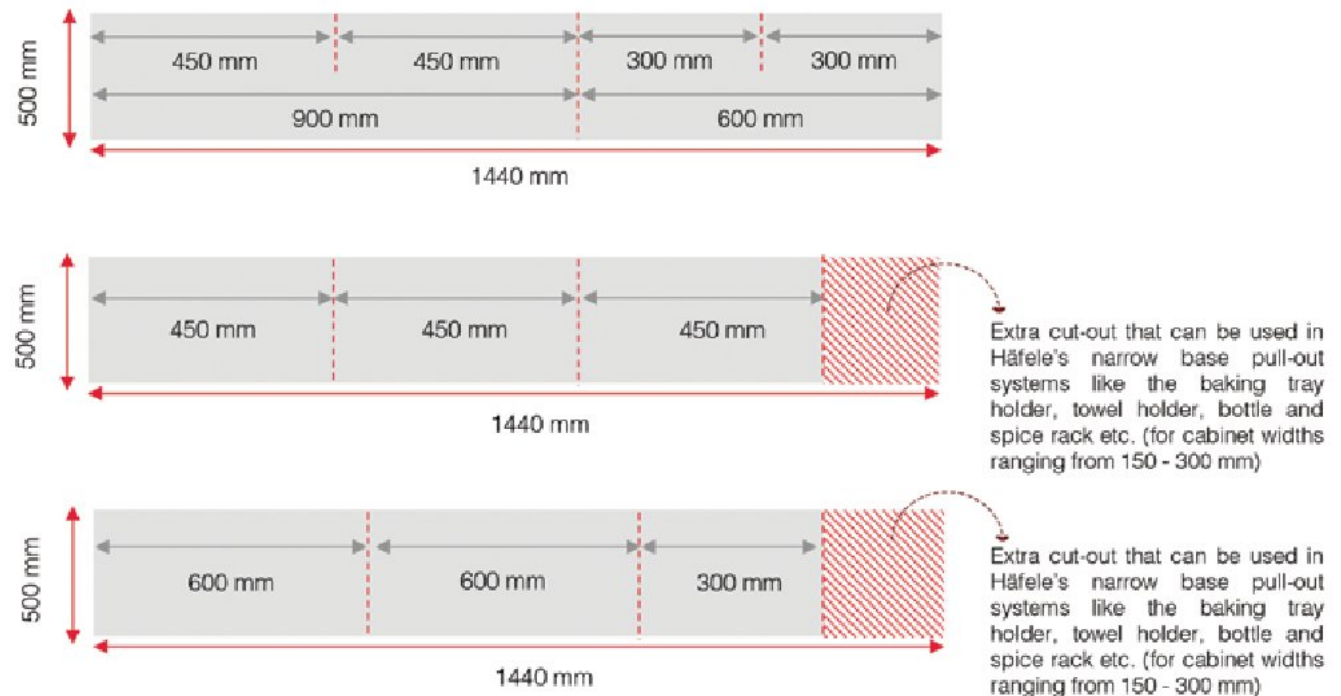

Aqua Under Sink / wall Mats



Aqua under sink mats are used in sink cabinets to prevent the bottom of the carcass from getting spoiled by water. The sink mats are made of plastic and have a specially designed spherical surface which can hold up to 6 litres of liquid per m². The mat provides protection against water and other leaking liquids in the sink cabinet. It stops water from damaging the drawer bottoms (wet kitchen issue).

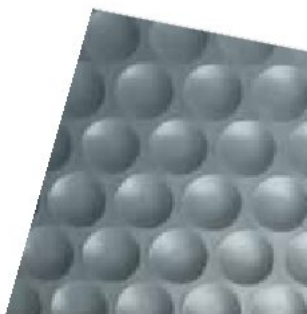

1 Aqua Under Sink Mat - Aluminium Metallic



2 Aqua Under Sink Mat - White

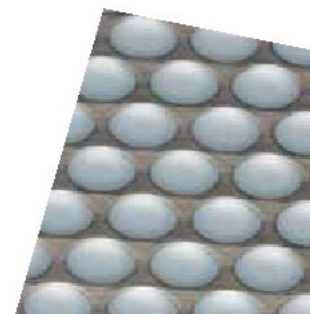

3 Grey with stainless steel foil



4/5 Aqua Wall Unit Mat

ORDERING INFORMATION

Product Description	Size (mm)	Color	Article No.
1 Aqua Sink Mats - Thickness 2.2 mm	Width 2000 x 580 x 2.2	Aluminium Metallic	547.91.003
2 Aqua Under Sink Mat -Thickness 2.2 mm	Width 2000 x 580 x 2.2	White	547.91.803
3 Aqua Sink Mats - Thickness 2.2 mm	Width 2000 x 580 x 2.2	Grey with SS foil	547.91.903
4 Aqua Wall Unit Mat	563 x 300 x 2.2	White with SS foil	547.91.008
5 Aqua Wall Unit Mat	863 x 300 x 2.2	White with SS foil	547.91.009

DRAWER ORGANISERS



Cuisio Cutlery Tray for MatrixBox Premium



Cuisio cutlery tray is an elegant and high-value insert system for drawers. It has inspiring material mix of translucent plastic trays and Aluminium connecting profiles. Due to its sophisticated clip connection it flexibly adapts to different drawer widths. Each tray can be individually equipped with adjustable dividers providing individual freedom to organize the drawers to one's requirements.

- Covers complete drawers
- Comes with sealing profiles so that the dust and spillover do not end up at the bottom of drawer
- Three finishes to perfectly match the aesthetics of MatrixBox Premium drawers



1 White Cuisio Cutlery Tray With Aluminium Profile



2 Graphite Translucent Cuisio Cutlery Tray With Aluminium Profile



3 Black Translucent Cuisio Cutlery Tray With Aluminium Profile

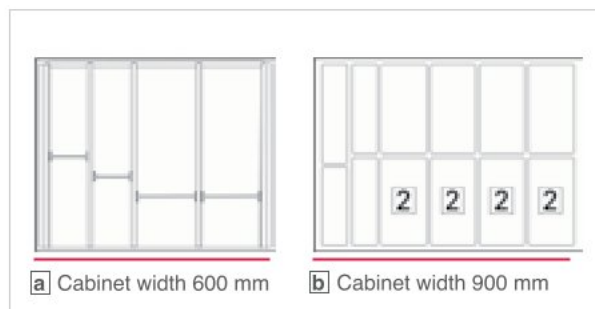

a Cabinet width 600 mm

b Cabinet width 900 mm

ORDERING INFORMATION

Product Description	Article No.
1a White Cuisio Cutlery Tray for cabinet width 600 mm	553.65.727
1b White Cuisio Cutlery Tray for cabinet width 900 mm	556.90.816
2a Graphite Translucent Cuisio Cutlery Tray for cabinet width 600 mm	553.65.827
2b Graphite Translucent Cuisio Cutlery Tray for cabinet width 900 mm	553.65.829
3a Black Translucent Cuisio Cutlery Tray for cabinet width 600 mm	553.65.427
3b Black Translucent Cuisio Cutlery Tray for cabinet width 900 mm	553.65.429

Ergo-Fit Cuisio for MatrixBox Slim

Additional storage space is a benefit, but efficiently organized storage space is a true blessing. When our surroundings are uncluttered, our minds are more creative, peaceful and efficient. To sort and organize your kitchen utilities, Häfele brings to you its Ergo fit Cuisio Cutlery Organizers in an all new Black finish, especially designed for the MatrixBox Slim Drawer Systems. These elegant and high value insert systems for drawers, consist of translucent plastic trays of varying sizes that can be arranged in a configuration that feels the most convenient to you with help of premium Aluminium connecting profiles. Each tray can be individually equipped with adjustable dividers, that help create internal segregation, providing individual freedom to organize the drawers to your storage requirements. The rising trend and demand for dramatic black interiors and furniture is here to stay and Häfele's Ergo fit Cuisio Cutlery Organisers in the new translucent black finish are sure to help you achieve the contemporary kitchen interior you desire!

- **Material:** Plastic (tray) / Aluminium (connecting profile)
- **Finish:** Graphite translucent



1 Ergo-Fit Cuisio for 450 mm Drawer

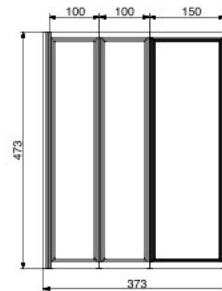

2 Ergo-Fit Cuisio for 600 mm Drawer

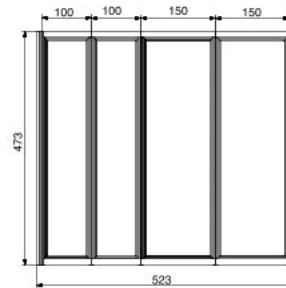

3 Ergo-Fit Cuisio for 900 mm Drawer

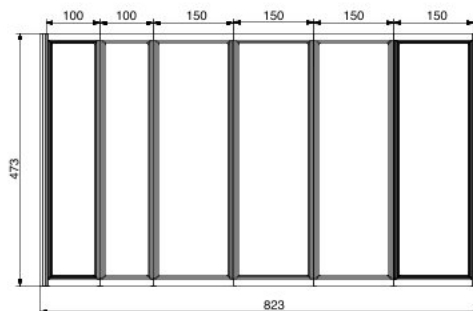

Note 1:

Only the Cuisio Drawer Organizers are provided by Häfele. The different drawer accessories shown in the images need to be procured separately.



4 Ergo-Fit Cuisio for 1200 mm Drawer

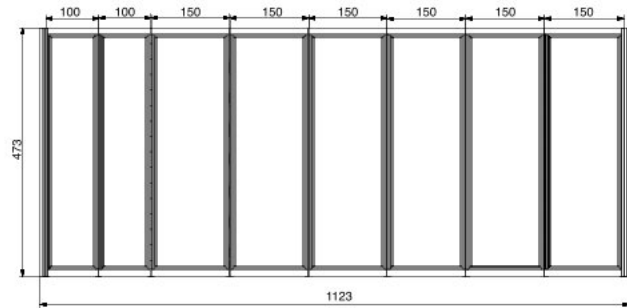

Configuration and assembly

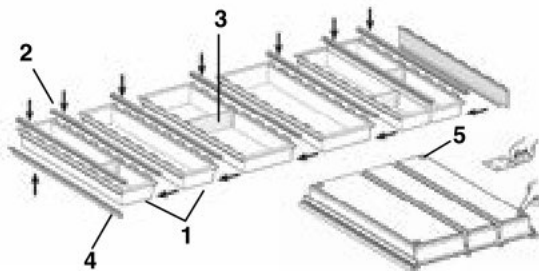

Each box of the Cuisio Cutlery Inserts consists of the following components:

1. Trays (100 mm / 150 mm) primary storage element
2. Connecting Profiles help join two trays together; number of connecting profiles = number of trays + 1
3. Dividers create partitions inside the trays; number of dividers = number of trays
4. End Walls cover the minimal gap between the drawer side and the tray. These can be used at extreme ends of the trays if the collective tray / organizer size is approximately equal to the internal drawer width; number of end walls = 2
5. Buffers prevent direct contact between the drawer base and trays



Connection between the drawer side and tray at both ends

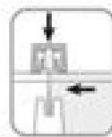

Connection between two trays with the connecting profiles

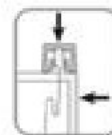

Connecting profiles can be used at the extreme ends of the trays if the collective tray / organizer size is smaller than the drawer size

ORDERING INFORMATION

Product Description	Drawer Width (mm)	Dimensions (mm)	Article No.
1 Ergo-Fit Cuisio for MatrixBox Slim, No of trays: 1 x 150 mm and 2 x 100 mm	450	473 (D) x 373 (W) x 55 (H)	550.79.202
2 Ergo-Fit Cuisio for MatrixBox Slim, No of trays: 2 x 150 mm and 2 x 100 mm	600	473 (D) x 523 (W) x 55 (H)	550.79.204
3 Ergo-Fit Cuisio for MatrixBox Slim, No of trays: 4 x 150 mm and 2 x 100 mm	900	473 (D) x 823 (W) x 55 (H)	550.79.206
4 Ergo-Fit Cuisio for MatrixBox Slim, No of trays: 6 x 150 mm and 2 x 100 mm	1200	473 (D) x 1123 (W) x 55 (H)	550.79.207

Note 2:

The configurations shown in the images above are for representation purposes only. The individual trays within a set can be arranged in any desired order.

Ergo-Fit Plastic Cutlery Organisers for MatrixBox Premium

Ergo-fit Sky

Ergo-fit Sky cutlery trays feature clear variable structures for your modern kitchen. The combination of fixed elements and movable dividers within the multipurpose compartments introduces both good looks and organization to the drawers. The new linear design with continuous line work harmoniously complements the design of the drawer guide systems.

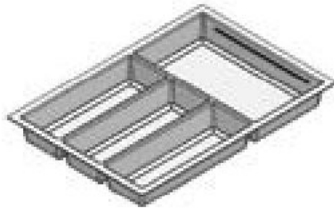

1 Ergo-Fit, Sky Cutley Tray For 450 mm Drawer Silver Grey

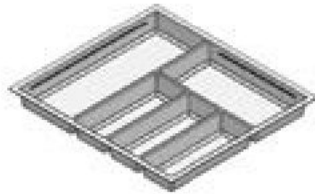

2 Ergo-Fit, Sky Cutley Tray For 600 mm Drawer Silver Grey



3 Ergo-Fit, Sky Cutley Tray For 900 mm Drawer Silver Grey

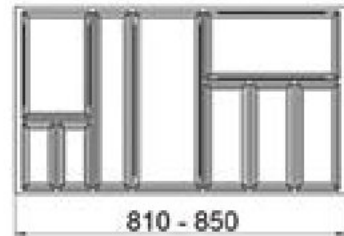
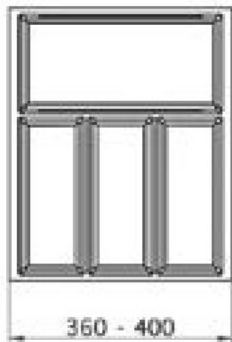

ORDERING INFORMATION

Product Description		Article No.
1	Ergo-Fit, Sky Cutley Tray for 450 mm Drawer Silver Grey	556.55.523
2	Ergo-Fit, Sky Cutley Tray for 600 mm Drawer Silver Grey	556.55.526
3	Ergo-Fit, Sky Cutley Tray for 900 mm Drawer Silver Grey	556.55.529

Ergo-Fit Plastic Cutlery Organisers for MatrixBox Premium



Ergo-fit Smart

The Ergo-fit Smart cutlery organiser series grabs attention on account of its high level of convenience in providing storage space for all commonly used kitchen utensils. In terms of functionality and design the division and arrangement of the compartments leave nothing to be desired

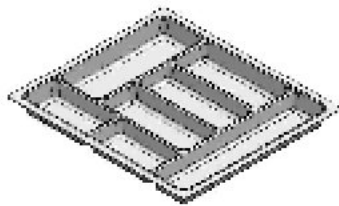

1 Cutlery tray for 600mm

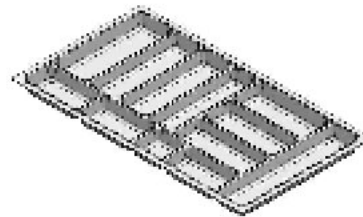

2 Cutlery tray for 900mm

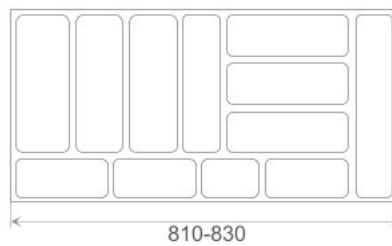
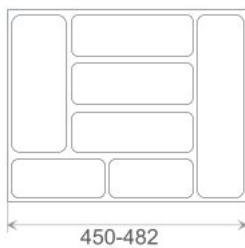

ORDERING INFORMATION

Product Description	Article No.
1 Ergo-Fit, Smart Cutlery Tray for 600 mm Drawer Silver Grey	556.72.528
2 Ergo-Fit, Smart Cutlery Tray for 900 mm Drawer Silver Grey	556.72.531

Box Frame Drawer Organisers

Organizing the kitchen successfully does one and only one thing: makes life simpler. When it comes to getting organized, it is the little things that can make all the difference. A muddle in the kitchen, clutters not only the worktop but also your creativity. It is therefore desirable to have things out of the way.

Easy accessibility and ergonomics are ensured with the various ranges of sleek and elegant drawer organizers by Häfele.

Häfele's all new range of bamboo box frame drawer organisers lets you discover your unexplored creativity and utilise optimum drawer space with uncompromised customisation.

- Made of bamboo, these organisers are ideal since the material is of a hard wearing and durable quality.
- It is naturally water-repellent which helps you keep your kitchen dry and fresh always.
- Cutlery organisers available in widths of 100, 200 & 300 mm
- Plate organisers are available in widths of 200 & 300 mm
- Organisers available with matching accessories like knife holder, spice container holder, foil cutter etc.



1 Drawer Organiser 100 mm Module



2 Drawer Organiser 200 mm Module



3 Drawer Organiser 300 mm Module



4 Cutlery Insert 100 mm Foil Cutter Module



5 Cutlery Insert 100 mm Knife Holder Module



6 Cutlery Insert 100 mm Spice Can Module (with spice cans)



7 High Fronted Pull Out Organiser 300 mm Module



8 Pull Out Organiser 200 mm Module

ORDERING INFORMATION

Product Description		Dimensions W x D x H (mm)	Article No.
1	Drawer Organiser 100 mm Module	100 x 472 x 55	550.38.400
2	Drawer Organiser 200 mm Module	200 x 472 x 55	550.38.401
3	Drawer Organiser 300 mm Module	300 x 472 x 55	550.38.402
4	Cutlery Insert 100 mm Foil Cutter Module	100 x 472 x 55	550.38.470
5	Cutlery Insert 100 mm Knife Holder Module	100 x 472 x 55	550.38.460
6	Cutlery Insert 100 mm Spice Can Module (with spice cans)	100 x 472 x 55	550.38.450
7	Pull Out Organiser 300 mm Module	300 x 472 x 150	550.38.481
8	Pull Out Organiser 200 mm Module	200 x 472 x 150	550.38.480

Ergo-Fit Wooden Cutlery Organisers



Ergo-Fit Cutlery Frames And Trays

Häfele's Ergo-fit range of Wooden Cutlery Frames / Trays lets you discover your unexplored creativity and utilise optimum drawer space with uncompromised customisation. They are made of bamboo and compact laminate which is ideal since the materials are of a hard wearing and durable quality. Moreover they are naturally water-repellent which helps you keep your kitchen dry and fresh always. The trays come with matching accessories like knife holder, spice jar holder, universal tray etc.



1 Drawer Organiser
100 mm wooden Module
Black



2 Drawer Organiser
100 mm wooden Module
Black



3 Drawer Organiser
200 mm wooden Module
Black



4 Drawer Org Wooden
Spice Can Holder 100mm,
Black (4 Spice Cans Included)



5 Drawer Organiser
200 mm Module, Black

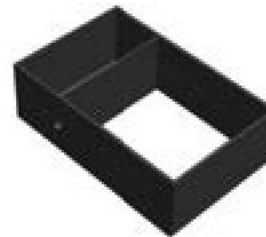

6 Drawer Organiser
300 mm Module, Black

ORDERING INFORMATION

Product Description	Dimensions W x D x H (mm)	Article No.
1 Drawer Org Wooden Module 100 mm, Black	100 x 472 x 55	550.38.300
2 Drawer Org Wooden Module 200 mm, Black	200 x 472 x 55	550.38.301
3 Drawer Org Wooden Module 300 mm, Black	300 x 472 x 55	550.38.302
4 Drawer Org Wooden Spice Can Holder 100 mm, Black	100 x 472 x 55	550.38.351
5 Box Frame PIO Org Module 200 mm, Black	200 x 472 x 150	550.38.380
6 Box Frame PIO Org Module 300 mm, Black	300 x 472 x 150	550.38.381

Plate Organiser

Easy access; clear overview; organized storage!

Häfele brings to you another kitchen accessory which ranks high on functionality. The all new plate storage rack facilitates easy storage and organization of your entire range of plates.

Features:

- Plate organization available in silver texture
- For organizing plate storage in the kitchen
- Plates go straight from the dishwasher into the rack
- Giving you instant access to the plate you require
- The plate rack is available in the size D 500 mm / W 900mm / W 600 mm

Material: Polystyrene

Number of plates:

- 32 plates (600mm)
- 42 plates (900mm)

Thickness of the plate: 2.5 mm / suitable for 16,18 and 19 mm wall thickness / carcass (adaptable)

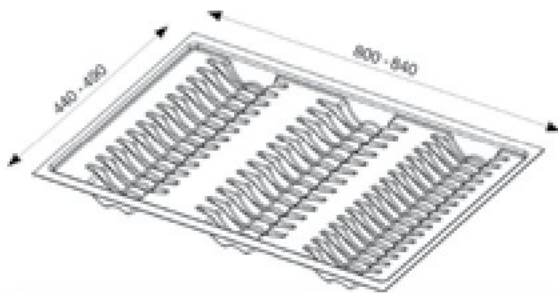

1 Plate organiser for drawer

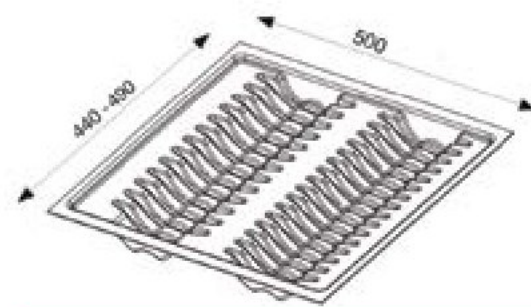

2 Plate organiser for drawer

ORDERING INFORMATION

	Product Description	Width (mm)	Height (mm)	Article No.
1	Plate organiser for drawer 900mm Silver D Texture	900	60	556.50.557
2	Plate organiser for drawer 600mm Silver D Texture	600	60	556.50.556

Ergo-Fit Plastic Cutlery Organisers



Ergo-Fit Connect

Häfele's Range of Ergo-fit Connect Cutlery Trays creates order inside your drawers and brings out the designer in you. Made in a practical 25 mm grid format, a range of different elements with a harmonious linear design, connect with each other to create limitless layouts. This system works in any drawers and can be customised for different depths and widths.

To be used with Skido Mat



1 Ergo Fit - Connect, Single Tray, Dark Grey



2 Ergo Fit - Connect, Partition Tray, Dark Grey



3 Ergo Fit - Connect, Small L Divider - Dark Grey



4 Ergo Fit - Connect, Large L Divider - Dark Grey



5 Ergo Fit - Connect, E Divider - Dark Grey



6 Ergo Fit - Connect, Connector (Red)

ORDERING INFORMATION

Product Description	Dimensions W x D x H (mm)	Article No.
1 Ergo Fit - Connect, Single Tray, Dark Grey	100 x 300 x 50	556.31.420
2 Ergo Fit - Connect, Partition Tray, Dark Grey	200 x 400 x 50	556.31.430
3a Ergo Fit - Connect, Small L Divider- Right, Dark Grey	100 x 200 x 50	556.31.440
3b Ergo Fit - Connect, Small L Divider- Left, Dark Grey	100 x 200 x 50	556.31.441
4a Ergo Fit - Connect, Large L Divider- Left, Dark Grey	100 x 250 x 50	556.31.450
4b Ergo Fit - Connect, Large L Divider- Right, Dark Grey	100 x 250 x 50	556.31.451
5 Ergo Fit - Connect, E Divider, Dark Grey	100 x 200 x 50	556.31.460
6 Ergo Fit - Connect, Connector (Red)		556.31.590

Ergo-Fit Plastic Cutlery Organisers

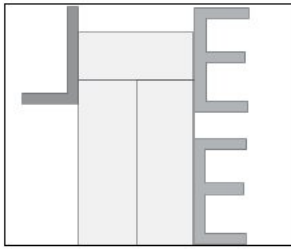

1 Plate organiser for drawer

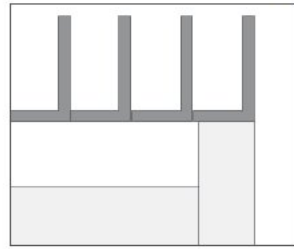

2 Plate organiser for drawer

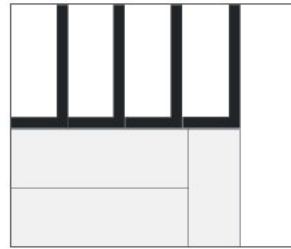

3 Plate organiser for drawer

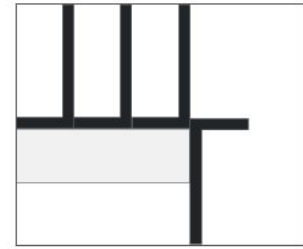

4 Plate organiser for drawer



5 Plate organiser for drawer

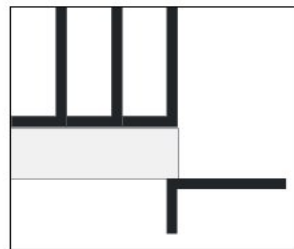

6 Plate organiser for drawer

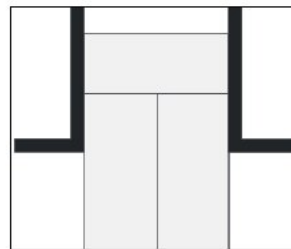

7 Plate organiser for drawer

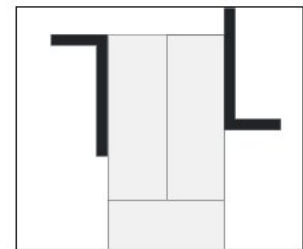

8 Plate organiser for drawer

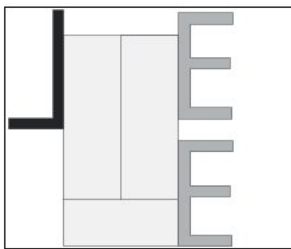

9 Plate organiser for drawer

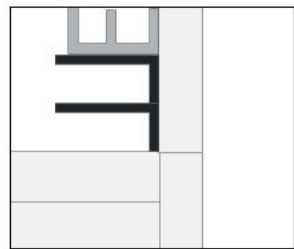

10 Plate organiser for drawer

ORDERING INFORMATION

Product Description	Article No.
1 Ergo Fit - Connect Set 1, Dark Grey	556.32.420
2 Ergo Fit - Connect Set 2, Dark Grey	556.32.421
3 Ergo Fit - Connect Set 3, Dark Grey	556.32.440
4 Ergo Fit - Connect Set 4, Dark Grey	556.32.441
5 Ergo Fit - Connect Set 5, Dark Grey	556.32.442
6 Ergo Fit - Connect Set 6, Dark Grey	556.32.444
7 Ergo Fit - Connect Set 7, Dark Grey	556.32.445
8 Ergo Fit - Connect Set 8, Dark Grey	556.32.446
9 Ergo Fit - Connect Set 9, Dark Grey	556.32.460
10 Ergo Fit - Connect Set 10, Dark Grey	556.32.461

Ergo-Fit Plastic High-Fronted Organisers



Ergo-Fit CUISIOFlex

A good organization system convinces by its simplicity and versatility. The items that have to be organized and stored do constantly vary in daily use. Due to its telescopically adjustable frame the Ergo-fit cuisioFLEX can perfectly adapt to the requirements of any kitchen. Also as a solitary, free-standing frame on the worktop, it cuts a fine figure.



1 Ergo Fit - Cuisioflex



2 Ergo Fit - Cuisioflex

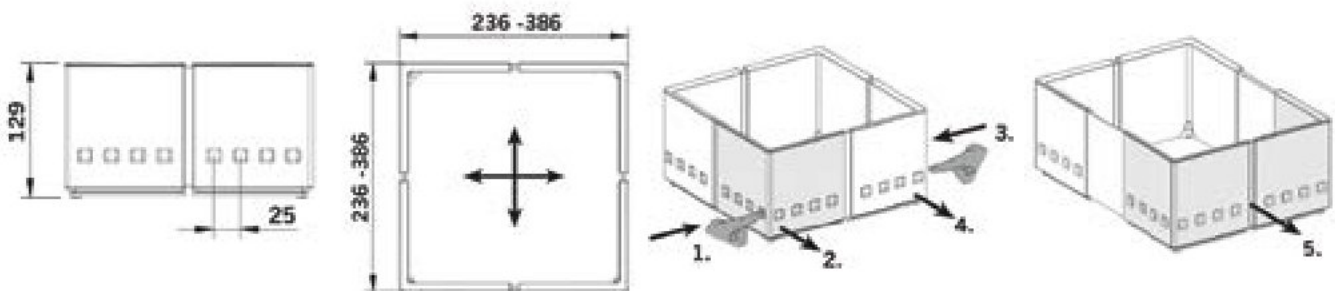

ORDERING INFORMATION

Product Description	Dimensions W x D x H (mm)	Article No.
1 Ergo Fit - Cuisioflex - Alu Grey With White Translucent	236-386 x 236-386 x 129	556.81.572
2 Ergo Fit - Cuisioflex - Dark Grey With Graphite Translucent	236-386 x 236-386 x 129	556.81.473

FLAP & LID STAYS LIFT UP SYSTEMS





Free Flap 1.7 / 3.15

- Hinge-less stay: flap fittings** The two models - Free flap 1.7 and 3.15 are designed for all of the most common cabinet height and flap weight combinations
- For front panels made from wood, glass or with aluminium frame
- Common mechanism to achieve Soft Close or Push-to Open motion
- Area of application:** For stay flap front panels with or without handle (push-to-open)
- Material:** Fitting: Steel, Cover cap: Plastic
- Finish/colour:** Fitting: Nickel plated, Cover cap: Grey, white or anthracite
- For cabinet height:** 200-450 mm (1.7) / 350-650 mm (3.15)
- Min. cabinet depth:** 109 mm (1.7) / 132 mm (3.15)
- Opening angle:** 90° or 107° (In 1.7, opening angle of 90° can be achieved by adding an optional opening angle restraint; in 3.15 the angles are adjustable on the fitting)
- Adjustment facility:** Height/lateral/ tilting angle of front panel ±1.5 mm, Weight balancing of front panel
- Installation:** Fitting: for screw fixing on pre-drilled side panel with pre-mounted Euro screws and built-in positioning pins, Front Panel: Tool-free assembly (clip system) onto pre-mounted screw-on brackets of the mechanism arms.



Free Flap 1.7 Sets*

Free Flap 3.15 Sets*



Narrow Aluminium Frame Adapters

Opening Angle Stop

Cover Caps

ORDERING INFORMATION

Product Description	
Free Flap 1.7 Sets*	
Model	Article No.
A	372.38.151
B	372.38.152
C	372.38.153
Free Flap 3.15 Sets*	
Model	Article No.
D	372.38.154
E	372.38.155
F	372.38.156
G	372.38.157

*Consist of: Free Flap 1.7 Lift Mechanism - Left and Right, 2 Front Fixing Brackets for Wooden Front Panels or Front Panels with Wide Aluminium Frame (Min. Frame Width: 45 mm) and Paper Template

*Consist of: Free Flap 3.15 Lift Mechanism - Left and Right, 2 Front Fixing Brackets for Wooden Front Panels or Front Panels with Wide Aluminium Frame (Min. Frame Width: 45 mm) and Paper Template

Cover Caps

Free Flap System	Anthracite	Grey	White
1.7	372.38.158	372.38.159	372.38.160
3.5	372.38.161	372.38.162	372.38.163

Note: Unit: 1 Pair
Cover caps for Free Flap 3.15 are also suitable for installation with Free Flap 1.7

Opening Angle Stop

Product Description	Finish	Article No.
> For limiting opening angle of 107° to 90°	Black	372.91.499
> Only applicable for Free Flap 1.7 sets		

Unit: 1 Pair

Narrow Aluminium Frame Adapters

Product Description	Finish	Article No.
> For flaps with 20 mm aluminium frame > M4 x 10 mm fixings included > Material: Zinc alloy	Nickel-plated	372.91.599

Note: Unit: 1 Pair
Fitting is visible with float and satin frosted glass, passe-partout or obscure glass may therefore be used.

Free Flap 1.7 / 3.15 - Push-to-open accessories

Push-to-Open Triggers and Housing

Colour-coded housing underside for differentiation between models type 1 (green), type 2 (yellow) and type 3 (blue)

Push-To-Open Triggers

- For mounting in drilled hole \varnothing 10 x 90 mm
- **Material:** Plastic with rubber buffer

Screw-On Housing

- **Recommended type of screw:** Head \varnothing : 7-9 mm, Thread \varnothing 3.5–4.5 mm, Screw length >15 mm
- **Material:** Plastic



Push-To-Open Triggers

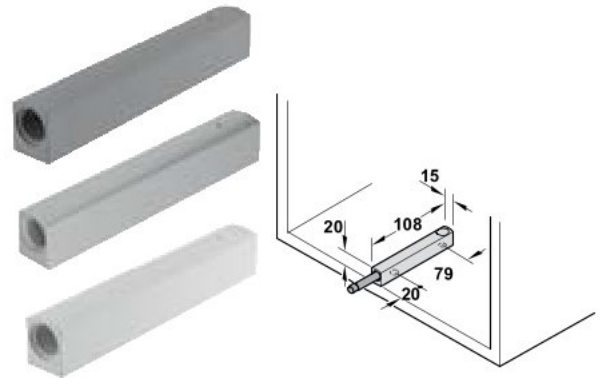

Screw-On Housing

ORDERING INFORMATION

Push-To-Open Triggers					
Model	Colour Code	Ejection Force	Anthracite	Grey	White
Type 1	Green	17 - 23 N	372.91.390	372.91.500	372.91.700
Type 2	Yellow	22 - 34 N	372.91.391	372.91.501	372.91.701
Type 3	Blue	26 - 48 N	372.91.392	372.91.502	372.91.702
Screw-On Housing			372.91.393	372.91.503	372.91.703

Unit: 1 Piece

Free Flap 1.7 / 3.15 - E-Drive

- **Material:** Fitting: Nickel plated,
Cover cap: Grey, white or anthracite
- **For flap width:** <1,200 mm (>1,200 mm = 2 sets)
- **Min. cabinet depth:** 109 mm (1.7) / 132 mm (3.15)
- **Input voltage:** 100–240 V AC/50–60 Hz/1.3 A
- **Nominal voltage:** 24 V DC/3.75 A
- **Output voltage:** For interior cabinet lighting: 24 V DC/1.2 A
- **Stand-by power consumption:** 1 W
- **Radio frequency:** 2.4 GHz
- **Protection class:** II
- **Installation:** E-Drive unit for screw fixing onto left Free fitting, Push button sender for recess installation in side panel (drill hole Ø 35 mm)



Sets



E-drive set for free flap 1.7 / 3.15*

E-drive add on accessory



E-Drive free flap cover cap set*

ORDERING INFORMATION

E-Drive Set For Free Flap 1.7 / 3.15*			
For Models			Article No.
A - G			372.38.165
*Consists of: 1 Free Flap 1.7 / 3.15 E-Drive Unit, 1 Loox Driver: 90 W- 24V, 1 Loox Power Supply Cable and 1 Connection Cable			
E-Drive Free Flap Cover Cap Set*			
Free Flap Systems	Anthracite	Grey	White
1.7 E / 3.15 E	372.38.186	372.38.185	372.38.184
*Consists of: 1 Cover Cap for E-Drive (left) and 1 Cover Cap for Free Flap 3.15 (right)			

Unit: 1 Set

Free Fold

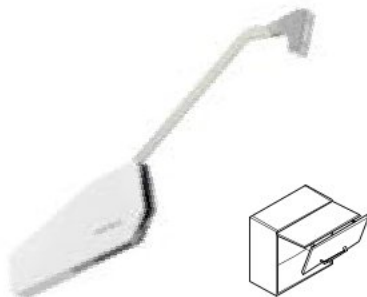

Free fold:
Only 288 mm wide and 25.5 mm slim



Opening angle stop

Opening Angle Stop

- Restricts the opening angle to 90° for low level applications
- **Material:** Plastic
- 2 pieces required per flap fitting set

- For two-piece flaps with division 1:1 made from wood or with aluminium frame
- High front panels can be lifted up in a space-saving way
- The handle is reachable at all times
- Pleasant operating experience even with heavy flaps
- Stylish and compact design
- Flap front panel material combinations possible
- Minimum opening resistance, multi-position stop function and integrated soft opening and soft closing mechanisms for ease and convenience
- For use in combination with standard 110° concealed hinges
- Adaptable E-Drive for an electrically operated comfort solution
- Practical and quick installation
- **Material:** Fitting: Steel, Cover cap: Plastic
- **Finish/colour:** Fitting: Galvanised, Cover cap: Grey, white or anthracite
- **Max. cabinet height:** 1040 mm
- **Min. cabinet depth:** 288 mm
- **Max. cabinet width:** 1800 mm (with 4 lift mechanisms)



Hinge and adapter kit for narrow aluminium profile*



Cover caps

ORDERING INFORMATION

Product Description	Article No.
Hinge and Adapter Kit for Narrow Aluminium Profile*	372.38.122
*Consist of: 2 Narrow Aluminium Frame Adapters and 3 Narrow Aluminium Profile Hinges	

Product Description	Material	Anthracite	Grey	White
Cover Caps	Plastic	372.38.119	372.38.120	372.38.121
Unit: 1 Pair				

Product Description	Finish	Article No.
Opening Angle Stop	Grey	372.37.060

Unit: 1 Piece

Free Fold Sets*			
Model	Cabinet height (mm)	Flap weight (kg)	Article No.
C3fo	480-530	5.2-11.1	372.38.102
C4fo	480-530	7.8-16.3	372.38.103
C5fo	480-530	12.7-26.5	372.38.101
D3fo	520-590	4.8-10.3	372.38.105
D4fo	520-590	7.2-15.2	372.38.106
D5fo	520-590	11.8-24.5	372.38.104
E3fo	580-650	4.3-9.2	372.38.107
E4fo	580-650	6.5-13.5	372.38.108
F3fo	650-730	3.9-8.3	372.38.109
F4fo	650-730	5.8-12.2	372.38.110
G4fo	710-790	5.3-11.1	372.38.111
G5fo	710-790	8.7-18.0	372.38.112
H4fo	770-840	4.9-10.3	372.38.113
H5fo	770-840	8.0-16.7	372.38.114
I5fo	840-910	7.3-15.3	372.38.115
J5fo	910-970	6.8-14.2	372.38.116
K5fo	960-1010	6.5-13.5	372.38.117
K6fo	960-1010	8.6-17.3	372.38.118
L5fo	1000-1040	6.2-12.9	372.38.100

*Consist of: Free Fold Lift Mechanism - Left and Right, 2 Front Fixing Brackets for Wooden Front Panels or Front Panels with Wide Aluminium Frame (Min. Frame Width: 45 mm), 3 Connecting Hinges, 3 Metalla 510 110° Concealed Hinges, 3 Straight Clip Mounting Plates and Paper Template

Free Fold - E-Drive



- **Material:** Drive housing: Zinc alloy, Cover caps: Plastic
- **Finish/colour:** Fitting: Nickel plated, Cover cap: Grey, white or anthracite
- **For flap width:** <1,200 mm (>1,200 mm = 2 sets)
- **For cabinet height:** 480 –1040 mm
- **Input voltage:** 100–240 V AC/50–60 Hz/1.3 A
- **Nominal voltage:** 24 V DC/3.75 A
- **Output voltage:** For interior cabinet lighting: 24 V DC/1.2 A
- **Stand-by power consumption:** 1 W
- **Radio frequency:** 2.4 GHz
- **Protection class:** II
- **Installation:** E-Drive unit for screw fixing onto left Free fitting, Push button sender for recess installation in side panel (drill hole Ø 35 mm)

Sets



E-Drive Set For Free Fold*



E-Drive Free Fold Cover Cap Set*

ORDERING INFORMATION

E-Drive Set For Free Fold*	
For Models	Article No.
Applicable for all Free Fold models	372.38.164
*Consists of: 1 E-Drive Unit, 2 E-Drive Push Button Switches, 1 Loox Driver: 90 W -24V, 1 Loox Power Supply Cable and 1 Connection Cable	

Unit: 1 Set

E-Drive Free Fold Cover Cap Set*		
Anthracite	Grey	White
372.38.168	372.38.167	372.38.166

*Consists of: 1 Cover Cap for E-Drive (left) and 1 Cover Cap for Standard Fitting (right)

Unit: 1 Set

Free Swing

- For one-piece flaps made from wood or with aluminium frame
- Ideal for large flaps
- Swivels around cornice profiles and surface mounted lights
- Full access to the cabinet contents
- Stylish and compact design
- Minimum opening resistance, multi-position stop function and integrated soft opening and soft closing mechanisms for extremely pleasant operating feeling
- Adaptable E-Drive for an electrically operated comfort solution
- **Material:** Fitting: Plastic, steel, Cover cap: Plastic
- **Finish/colour:** Fitting: Nickel plated, Cover cap: Grey, white or anthracite
- **Max. cabinet height:** 800 mm
- **Min. cabinet depth:** 273 mm
- **Max. cabinet width:** 1800 mm (with 4 mechanisms)
- **Adjustment facility:** Height adjustment ± 1.5 mm, side adjustment ± 1.5 mm, tilting angle $\pm 1.5^\circ$, Weight balancing adjustment
- **Installation:** Fitting: for screw fixing on pre-drilled side panel with pre-mounted Euro screws and built-in positioning pins, Front Panel: Tool-free assembly (clip system) onto pre-mounted screw-on brackets of the mechanism arms



Free swing:
Only 273 mm wide and 25.5 mm slim (without arm)



Cover Caps



Cross Bar



Narrow Aluminium Frame Adapters

Cross Bar

- **Area of application:** For synchronising both fitting parts
- **Material:** Aluminium
- **Finish:** Silver coloured anodized
- Can be cut to size
- Cutting dimension = internal cabinet width – 88 mm
- **Side panel thickness W:** 16/19 mm

Narrow Aluminium Frame Adapters

- **Area of application:** For connecting narrow aluminium frames to front fixing brackets
- For flaps with 20 mm aluminium frame
- **Material:** Zinc alloy
- Fixing material supplied
- **Mounting:** For left or right hand use

ORDERING INFORMATION

Product Description	Material	Anthracite	Grey	White
Cover Caps	Plastic	372.38.148	372.38.149	372.38.150

Unit: 1 Pair

Product Description	Cabinet Width	Length	Article No.
Cross Bar	600 mm	474 mm	372.38.134
	1200 mm	1074 mm	372.38.138

Unit: 1 Piece

Product Description	Finish	Article No.
Narrow Aluminium Frame Adapters	Nickel plated	372.91.599

Note Fitting is visible with float and satin frosted glass, passe-partout or obscure glass may therefore be used. Unit: Pair

Free Swing Sets*			
Model	Cabinet Height(mm)	Flap Weight(in kg)	Article No.
S1SW	370-500	1.8-4	372.38.139
S2SW	500-670	2.5-5.9	372.38.142
S3SW	670-800	2.9-6.5	372.38.143
S4SW	370-500	3-6.5	372.38.140
S5SW	500-670	4.5-10	372.38.146
S6SW	670-800	5.3-11.3	372.38.144
S7SW	370-500	4.5-10.3	372.38.141
S8SW	500-670	7-15.9	372.38.147
S9SW	670-800	8-17.1	372.38.145

*Consist of: Free Swing Lift Mechanism - Left and Right,2 Front Fixing Brackets for Wooden Front Panels or Front Panels with Wide Aluminium Frame (Min. Frame Width: 45 mm), 2 Cross Bar Connectors and Paper Template

Free Swing - E-Drive

- **Material:** Fitting: Steel, Cover cap: Plastic, Drive housing: Zinc alloy
- **Finish/colour:** Fitting: Nickel plated, Cover caps: Grey, white or anthracite
- **For cabinet height:** 370 - 800 mm
- **For flap width:** <1,200 mm (>1,200 mm = 2 sets)
- **Input voltage:** 100–240 V AC/50 - 60 Hz/1.3 A
- **Nominal voltage:** 24 V DC/3.75 A
- **Output voltage:** For interior cabinet lighting: 24 V DC/1.2 A
- **Stand-by power consumption:** 1 W
- **Radio frequency:** 2.4 GHz
- **Protection class:** II
- **Installation:** E-Drive unit for screw fixing onto left Free fitting, Push button sender for recess installation in side panel (drill hole Ø 35 mm)



Sets



E-Drive Set For Free Swing*



Free Swing E Drive Cover Cap Set*

ORDERING INFORMATION

E-Drive Set For Free Swing*

For Models

Applicable for all Free Swing models

Article No.

372.38.164

*Consists of: 1 E-Drive Unit, 2 E-Drive Push Button Switches, 1 Loox Driver: 90 W -24V, 1 Loox Power Supply Cable and 1 Connection Cable

E-Drive Free Swing Cover Cap Set*

Anthracite

372.38.168

Grey

372.38.170

White

372.38.169

*Consists of: 1 Cover Cap for E-drive (left), 1 Cover Cap for Standard Fitting (right) and 1 E-Drive Lever Arm

Unit: 1 Set

Free Up



Free Up:
Only 277 mm wide and 25.5 mm slim

- For one-piece flaps made from wood or with aluminium frame
- Can be used in combination with upper-mounted cabinets or front panels
- Creates practical “niches” in tall cabinets, e.g. for electrical equipment
- Cabinet contents are extremely easy to access
- Excellent side stability
- Minimum opening resistance, multi-position stop function and integrated soft opening and soft closing mechanisms for extremely pleasant operating feeling
- Adaptable E-Drive for an electrically operated comfort solution
- Stylish and compact design
- **Material:** Fitting: Plastic, steel, Cover cap: Plastic
- **Finish/colour:** Fitting: Nickel plated, Cover cap: Grey, white or anthracite
- **Max. cabinet height:** 600 mm
- **Min. cabinet depth:** 277 mm
- **Max. cabinet width:** 1800 mm (with 4 mechanisms)
- **Adjustment facility:** Height adjustment ± 1.5 mm, side adjustment ± 1.5 mm, tilting angle $\pm 1.5^\circ$, weight balancing adjustment facility
- **Installation:** Fitting: for screw fixing on predrilled side panel with pre-mounted Euro screws and built-in positioning pins, Front panel: Tool-free assembly (clip system) onto pre-mounted screw-on brackets of the mechanism arms



Cover Caps

Cross Bar

- **Area of application:** For synchronising both fitting parts
- **Material:** Aluminium
- **Finish:** Silver coloured anodized
- Can be cut to size
- Cutting dimension = internal cabinet width - 88 mm
- **Side panel thickness W:** 16/19 mm



Cross Bar

Narrow Aluminium Frame Adapters

- **Area of application:** For connecting narrow aluminium frames to front fixing brackets
- For flaps with 20 mm aluminium frame
- **Material:** Zinc alloy
- Fixing material supplied
- **Mounting:** For left or right hand use



Narrow Aluminium Frame Adapters

ORDERING INFORMATION

Product Description	Material	Anthracite	Grey	White
Cover Caps	Plastic	372.38.135	372.38.136	372.38.137

Unit: 1 Pair

Product Description	Cabinet Width	Length	Article No.
Cross Bar	600 mm	474 mm	372.38.134
	1200 mm	1074 mm	372.38.138

Unit: 1 Piece

Product Description	Finish	Article No.
Narrow Aluminium Frame Adapters	Nickel plated	372.91.599

Note

Fitting is visible with float and satin frosted glass, passe-partout or obscure glass may therefore be used.

Unit: Pair

Free Up Sets*			
Model	Cabinet Height(mm)	Flap Weight(in kg)	Article No.
P1us	345-420	2.4-4.8	372.38.123
P2us	345-420	4.1-8	372.38.124
P3us	345-420	7.4-14	372.38.127
Q1us	380-500	2.0-3.8	372.38.125
Q2us	380-500	3.4-6.7	372.38.126
Q3us	380-500	6.3-11.8	372.38.128
Q4us	380-500	9.3-17.4	372.38.129
R1us	430-600	1.6-3.3	372.38.130
R2us	430-600	2.6-5.5	372.38.131
R3us	430-600	5.0-9.7	372.38.132
R4us	430-600	7.4-14.6	372.38.133

Consists of: Free Up Lift Mechanism - Left and Right, 2 Front Fixing Brackets for Wooden Front Panels or Front Panels with Wide Aluminium Frame (Min. Frame Width: 45 mm), 2 Cross Bar Connectors and Paper Template

Free Up - E-Drive



- **Material:** Fitting: Steel, Cover cap: Plastic, Drive housing: Zinc alloy
- **Finish/colour:** Fitting: Nickel plated, Cover caps: Grey, white or anthracite
- **For cabinet height:** 345-600 mm
- **For flap width:** <1,200 mm (>1,200 mm = 2 sets)
- **Input voltage:** 100-240 V AC/50-60 Hz/1.3 A
- **Nominal voltage:** 24 V DC/3.75 A
- **Output voltage:** For interior cabinet lighting: 24 V DC/1.2 A
- **Stand-by power consumption:** 1 W
- **Radio frequency:** 2.4 GHz
- **Protection class:** II
- **Installation:** E-Drive unit for screw fixing onto left Free fitting, Push button sender for recess installation in side panel (drill hole Ø 35 mm)

Sets



E-Drive Set For Free Up*



Free Up E Drive Cover Cap Set*

E-Drive Set For Free Up*	
For Models	Article No.
Applicable for all Free Swing models	372.38.164
*Consists of: 1 E-Drive Unit, 2 E-Drive Push Button Switches, 1 Loox Driver: 90 W -24V, 1 Loox Power Supply Cable and 1 Connection Cable	

Free Up E Drive Cover Cap Set*			
Model	Anthracite	White	Grey
P	372.38.177	372.38.175	372.38.176
Q	372.38.180	372.38.178	372.38.179
R	372.38.183	372.38.181	372.38.182

*Consists of: 1 Cover Cap for E-Drive (left), 1 Cover Cap for Standard Fitting (right) and 1 E-Drive Lever Arm

Unit: 1 Set

Free Space

- Hinge-less stay lift system for more free room in all respects
- **Extremely powerful:** A product series that caters to majority of the most common flap sizes and weights
- **Extremely compact:** Minimal appearance and more storage space in the furniture
- Extremely gentle running characteristics for a pleasant operating feeling
- Extremely fast and time-saving processing
- **Extremely adaptable:** Three standard colours
- For flaps with handle and flaps without handle with push opening
- **Area of application:** For standard front panel applications with front height up to 650 mm
Fitting: Steel, Housing: Plastic
- **Material:** Fitting: Nickel plated, Housing: Grey, white or anthracite
- **Finish/colour:** Fitting: Nickel plated, Housing: Grey, white or anthracite
- **Opening angle:** 90° or 107°
- **Adjustment facility:** Height, side, tilting angle, holding power
- **Installation:** Fitting: for screw fixing on pre-drilled side panel with pre-mounted Euro screw and built-in positioning pins, Front panel: Tool-free assembly (clip system) onto pre-mounted fixing screws



ORDERING INFORMATION

Free space 1.11			
Model	Anthracite	Grey	White
B	372.27.920	372.27.925	372.27.930
C	372.27.921	372.27.926	372.27.931
D	372.27.922	372.27.927	372.27.932
E	372.27.923	372.27.928	372.27.933
F	372.27.924	372.27.929	372.27.934

Consists of: Free space 1.11 Lift Mechanism - Left and Right and 2 Front Fixing Brackets for Wooden Front Panels or Front Panels with Wide Aluminium Frame (Min. Frame Width: 45 mm).

Free space 1.8 Push to Open			
Model	Anthracite	Grey	White
B PTO	372.27.935	372.27.939	372.27.943
C PTO	372.27.936	372.27.940	372.27.944
D PTO	372.27.937	372.27.941	372.27.945
E PTO	372.27.938	372.27.942	372.27.946

Consists of: Free space 1.8 Push-to-Open Lift Mechanism - Left and Right, 2 Front Fixing Brackets for Wooden Front Panels or Front Panels with Wide Aluminium Frame (Min. Frame Width: 45 mm) and Push-to-Open Trigger.

Cabinet Height (mm)	Free Space				
	B (1.11 & 1.8)	C(1.11 & 1.8)	D(1.11 & 1.8)	E(1.11 & 1.8)	F(1.11)
	Flap Weight in Kg				
225	2.3-4.3	3.8-7.1	6.4-9.3	9.2-13.4	13.4-19.1
250	1.9-3.9	3.4-6.4	5.8-9.1	8.3-12.6	12.1-17.2
275	1.9-3.5	3.1-5.8	5.3-8.2	7.5-12.0	11.0-15.6
300	1.7-3.2	2.8-5.3	4.8-7.5	6.9-11.0	10.1-14.3
325	1.6-3.0	2.6-4.9	4.4-7.0	6.4-10.2	9.3-13.2
350	1.5-2.8	2.4-4.6	4.1-6.5	5.9-9.5	8.6-12.3
375	1.3-2.6	2.2-4.3	3.8-6.0	5.5-8.8	8.1-11.4
400	1.2-2.4	2.1-4.0	3.6-5.6	5.2-8.3	7.6-10.7
425	1.1-2.3	2.0-3.8	3.4-5.3	4.9-7.8	7.1-10.1
450	1.0-2.1	1.9-3.5	3.2-5.0	4.6-7.3	6.7-9.5
475	1.0-2.0	1.8-3.4	3.0-4.7	4.3-7.0	6.4-9.0
500	0.9-1.9	1.7-3.2	2.9-4.5	4.1-6.6	6.0-8.6
525	0.9-1.8	1.6-3.0	2.7-4.3	3.9-6.3	5.7-8.2
550	0.8-1.7	1.5-2.9	2.6-4.1	3.7-6.0	5.5-7.8
575	0.8-1.7	1.4-2.8	2.5-3.9	3.6-5.7	5.2-7.4
600	0.8-1.6	1.4-2.7	2.4-3.7	3.4-5.5	5.0-7.1
625	0.7-1.5	1.3-2.5	2.3-3.6	3.3-5.3	4.8-6.8
650	0.7-1.5	1.3-2.4	2.2-3.5	3.2-5.1	4.6-6.6

Lid Stays - Duo

Features

- **Opening angle:** 75°, 90° or 110° (with different opening angles of hinges)
- **Mounting:** For left and right hand use
- The Flap locks in any position and it stops in end position when released by slight pressure
- Can be mounted on wooden door flaps and for door flaps with aluminum frame
- Gentle push helps in opening and closing of the Flap/ Cabinet Door
- The mechanism is made of Zinc Alloy and the mounting bracket of steel.
- Flap weight bearing capacity is from 4kg - 15kg
- **Finish:** Black, Nickel plated & White
- **Flap height up to 500 mm**



Lid Stay - Duo

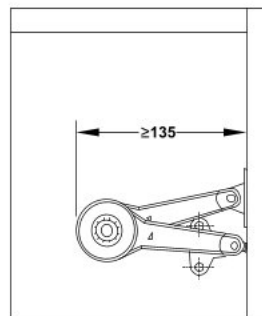

Min. installation depth

ORDERING INFORMATION

Product Description		Finish	Article No.
1	For flaps made of wood or with aluminum frame. Frame width 45 mm and above	Black	373.66.211*
2	For flaps made of wood or with aluminum frame. Frame width 45 mm and above	Nickel Plated	373.66.611
3	For flaps made of wood or aluminum frame. Frame width 45 mm and above	White	373.66.261*
4	For flaps with aluminum frame. Frame width 20 mm and above	Nickel Plated	373.66.621

*Special Order

Installation as lid stay

Opening angle 75°

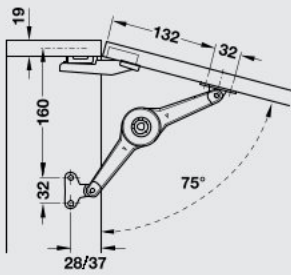

Cabinet height mm	Flap weight kg		Braking function	
	Locking function 1 fitting	2 fittings	1 fitting	2 fittings
250	7.0	15.0	9.0	15.0
300	6.0	12.0	7.5	15.0
350	5.0	10.0	6.5	13.0
400	4.5	9.0	6.0	11.5
450	4.0	8.0	5.0	10.0
500	3.5	7.0	4.5	9.0

Opening angle 90°

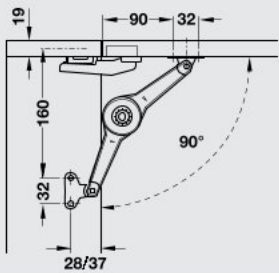

Cabinet height mm	Flap weight kg		Braking function	
	Locking function 1 fitting	2 fittings	1 fitting	2 fittings
250	6.0	12.0	7.5	15.0
300	5.0	10.0	6.5	13.0
350	4.5	8.5	5.5	11.0
400	4.0	7.0	5.0	10.0
450	3.5	6.5	4.5	8.5
500	3.0	6.0	4.0	7.5

Opening angle 110°

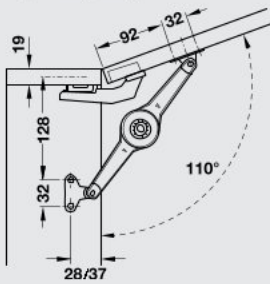

Cabinet height mm	Flap weight kg		Braking function	
	Locking function 1 fitting	2 fittings	1 fitting	2 fittings
200	6.0	12.0	8.0	15.0
250	5.0	9.5	6.0	12.0
300	4.0	8.0	5.0	10.0
350	3.5	7.0	4.0	9.0
400	3.0	6.0	4.0	7.5
450	2.5	5.5	3.5	7.0
500	2.0	5.0	3.0	6.0

Installation as flap stay (use 2 fittings)

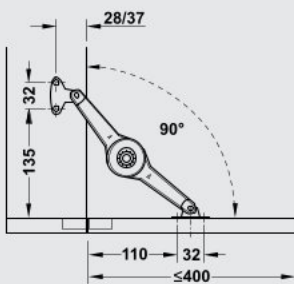

Separate catch required

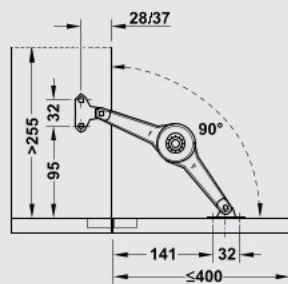

Separate catch is not required.

Application possible from a cabinet height of 300 mm (internal height min. 255 mm).
Space requirement for fitting inside the cabinet when the flap is being closed:
130 mm from front edge of cabinet

Cabinet height mm	Flap weight kg	
	Locking function 2 fittings	Braking function 2 fittings
200	15.0	15.0
250	12.0	15.0
300	10.0	13.0
350	8.5	11.0
400	7.0	10.0

Duo Forte

Features

- **Opening angle:** 75°, 90° or 110° (with different opening angles of hinges)
- **Mounting:** For left and right hand use
- The Flap locks in any position and it stops in end position when released by slight pressure
- Can be mounted on wooden door flaps and for door flaps with Aluminum frame
- Gentle push helps in opening and closing of the Flap/ Cabinet Door
- The mechanism is made of Zinc Alloy and the mounting bracket of Steel.
- Flap weight bearing capacity is from 4kg - 15kg
- Can be installed without tools (Clip mounting system)
- **Flap height up to 700 mm**
- **Area of application:** Also suitable for use as flap stays.
- **Distance from edge:** 28 mm
- **Finish:** Black, Nickel plated & White



Flap Stays - Duo Forte

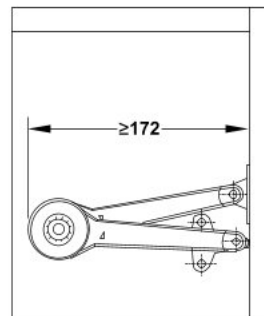

Min. installation depth

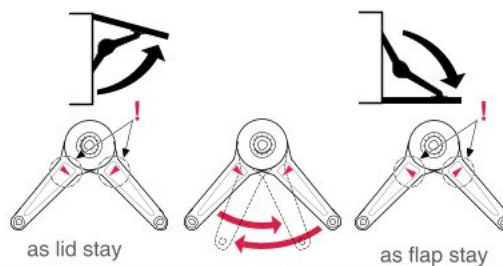

Application

ORDERING INFORMATION

Product Description	Finish	Article No.
1 Duo-Forte Flap Stay, for Wood/ED = 28 mm	Black	373.66.311*
2 Duo-Forte Flap Stay, for Wood/ED = 28 mm	Nickel Plated	373.66.631
3 Duo-Forte Flap Stay, for Wood/ED = 28 mm	White	373.66.371*
4 Duo-Forte Flap Stay, for Aluminum/ED = 28 mm	Nickel Plated	373.66.641

*Special Order

Installation as lid stay

Opening angle 75°

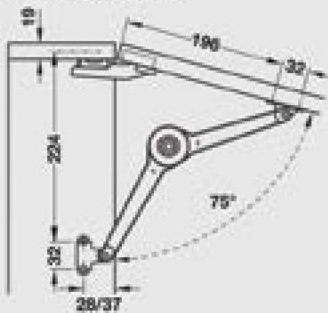

Cabinet height mm	Flap weight kg		Braking function	
	Locking function 1 fitting	2 fittings	1 fitting	2 fittings
300	9.0	15.0	12.0	15.0
350	8.0	15.0	11.0	15.0
400	7.0	14.0	9.0	15.0
450	6.0	12.5	8.0	15.0
500	5.5	11.0	7.0	15.0
550	5.0	10.0	6.5	13.0
600	5.0	9.5	6.0	12.0
650	4.0	8.5	5.5	11.0
700	4.0	8.0	5.0	10.5

Opening angle 90°

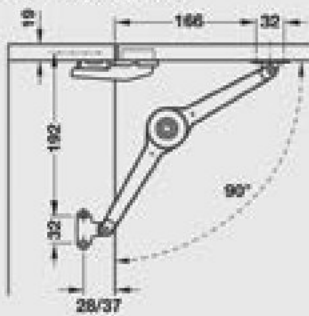

Cabinet height mm	Flap weight kg		Braking function	
	Locking function 1 fitting	2 fittings	1 fitting	2 fittings
300	7.5	15.0	9.0	15.0
350	6.5	13.5	8.0	15.0
400	6.0	12.0	7.5	15.0
450	5.5	11.0	7.0	14.0
500	5.0	9.5	6.0	12.0
550	4.5	8.5	5.5	11.0
600	4.0	8.0	5.0	10.0
650	3.5	7.0	5.0	9.5
700	3.0	7.0	4.0	9.0

Opening angle 110°

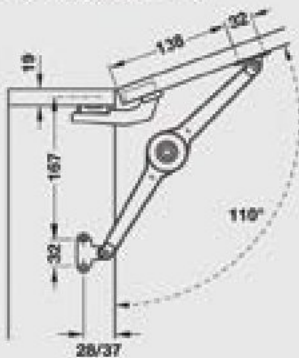

Cabinet height mm	Flap weight kg		Braking function	
	Locking function 1 fitting	2 fittings	1 fitting	2 fittings
250	7.5	15.0	10.0	15.0
300	6.5	12.5	8.0	15.0
350	5.5	11.0	7.0	14.0
400	4.5	9.5	6.0	12.5
450	4.0	8.5	5.5	11.0
500	4.0	7.5	5.0	10.0
550	3.5	7.0	4.0	9.0
600	3.0	6.0	4.0	8.0
650	3.0	5.5	4.0	7.5
700	3.0	5.0	3.5	7.0

Gas Spring

For Wood & Aluminum Shutters

- **Material:** Steel with powder coating
- **Finish:** Silver
- **Center to center:** 245±2 mm
- **Piston capacity:** 60,80,100,120,150 N
- **Weight capacity:** Refer chart
- **Usage:** For lid stay (upward opening)
- **Max panel height:** 600 mm
- **Max width:** 900 mm

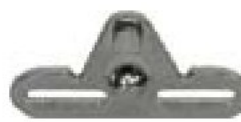

Mounting plate for wooden shutters



Mounting plate for carcass



Mounting plate for aluminum frame shutters

All mounting plates included in the packet

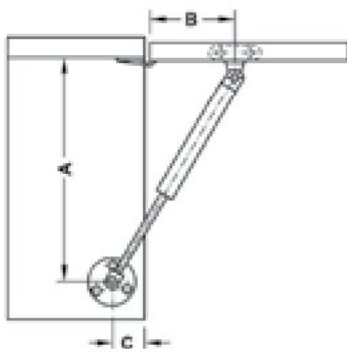

Mounting dimensions when using hinges for full overlay mounting

Opening Angle	Dim (mm)		
	A	B	C
75°	260	80	25
90°	238	80	25
110°	215	70	25

Weight for 1 pair of gas springs

Max. lid weight (kg) with 75° application				
Spring Force	Lid Height in mm			
N	300	400	500	600
60	4	3	2.4	2
80	5.4	4	3.2	2.8
100	6.8	5.2	4	3.4
120	8.2	6.2	5	4
150	9.4	7	5.8	4.8
Max. lid weight (kg) with 90° application				
Spring Force	Lid Height in mm			
N	300	400	500	600
60	3.6	2.6	2.2	1.8
80	4.8	3.6	2.8	2.4
100	6	4.4	3.6	3
120	7.2	5.4	4.2	3.6
150	8.2	6.4	4.6	4.2
Max. lid weight (kg) with 110° application				
Spring Force	Lid Height in mm			
N	300	400	500	600
60	3.2	2.4	1.8	1.6
80	4.2	3.2	2.4	2
100	5.2	3.8	3.2	2.6
120	6.2	4.6	3.8	3.2
150	7	5.2	4.4	3.8

ORDERING INFORMATION

Product Description	UOM	Article No.
1 Gas Spring Upward Opening C/C 245mm 60 N	Pair	483.98.060
2 Gas Spring Upward Opening C/C 245mm 80 N	Pair	483.98.061
3 Gas Spring Upward Opening C/C 245mm 100	Pair	483.98.062
4 Gas Spring Upward Opening C/C 245mm 120	Pair	483.98.063
5 Gas Spring Upward Opening C/C 245mm 150	Pair	483.98.064

Gas Spring (Upward Opening)



Specifications

- **Material:** Steel with powder coating
- **Finish:** Silver
- **Center to center:** 254±2 mm
- **Capacity:** 200 & 250 N



Opening Angle	Dim. mm		
	A	B	C
75°	249	82	15
90°	226	60	15
110°	269	102	15

1 & 2 Gas Spring (Upward Opening)

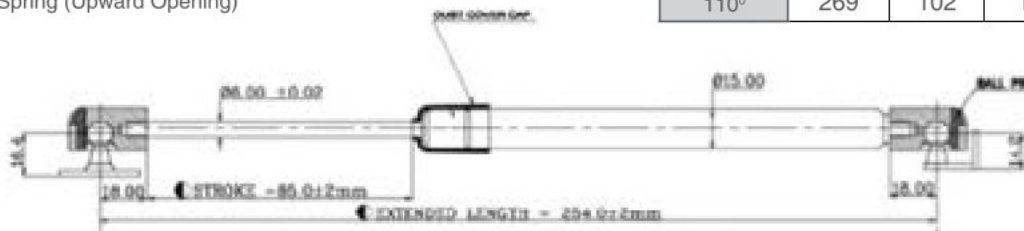

Weight for 1 pair of gas spring

Max. lid weight (kg) with 75° application					
Spring Force	Lid Height in mm				
N	300	400	500	600	700
200	16.2	12	10	8.4	7.6
250	21	15.8	13	10.8	10
Max. lid weight (kg) with 90° application					
Spring Force	Lid Height in mm				
N	300	400	500	600	700
200	16.2	11	8	7.2	6.2
250	21	14.4	20.4	9.4	8
Max. lid weight (kg) with 110° application					
Spring Force	Lid Height in mm				
N	300	400	500	600	700
200	12	9	7.6	6.6	6
250	15.8	11.8	10	8.6	7.6

Gas Spring (Downward Opening)

Specifications

- **Material:** Steel with powder coating
- **Finish:** Silver
- **Center to center:** 245±2 mm

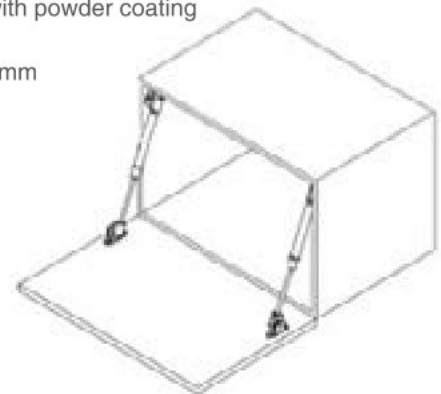

3 Gas Spring (Downward Opening)

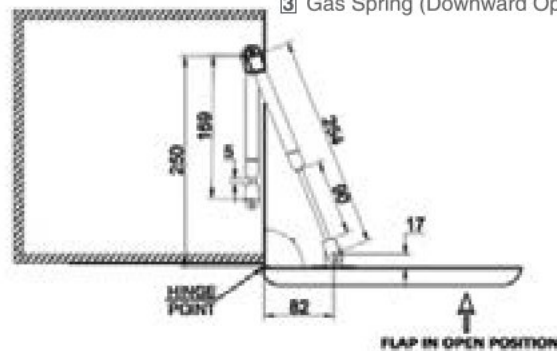

ORDERING INFORMATION

Product Description	UOM	Article No.
1 Gas Lift For Upward Opening C/C 254 mm 200 N	Pair	373.83.010
2 Gas Lift For Upward Opening C/C 254 mm 250 N	Pair	373.83.011
3 Gas Lift For Downward Opening C/C 245 mm	Pair	373.83.012

Kraby Lift Up

New design Opening System. Highest quality: each article individually checked and marked.

- Available in 244 mm & 355 mm lengths
- Wide range of N strengths, to suit any door dimension and weight
- Automatic Opening: Allows the door to open to the fullest
- Friction Opening: Allow door to be stopped in any required position.
- Open angle adjustment carried out by hand through the rotary knob, for nearby doors alignment
- Adjustment of the piston base plate within the "U" slot of the side bracket to change door opening and closing
- Quick and easy installation, no need to tension the strength
- Directly installed on solid or wider aluminium frame doors with wide range of special adapters to suit small aluminium door profiles
- All the parts (stay excluded) are in zinc alloy nickel plated and plastic
- In accordance with Italian Regulation UNI 8607/05 Level 5

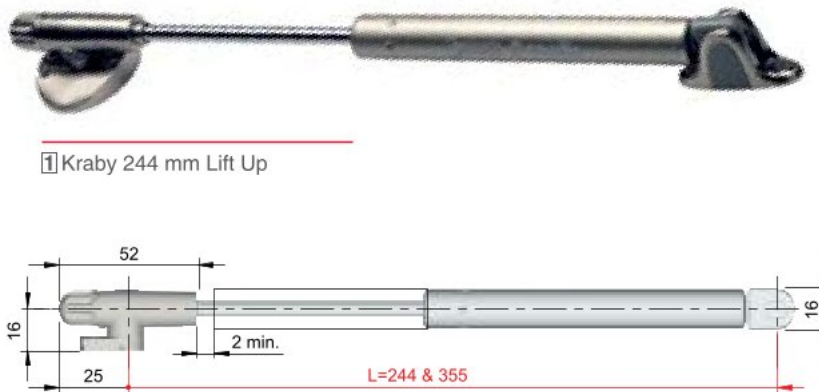

50 N, 120 N on demand  = 10 sets

ORDERING INFORMATION

Product Description	Article No.
Friction Version	
1 Kraby Friction 244 mm/60N+Accessories+Guide (1 Set)	373.86.742
2 Kraby Friction 244 mm/90N+Accessories+Guide (1 Set)	373.86.743
Automatic Version	
3 Kraby Automatic 244 mm/80N+Accessories+Guide (1 Set)	372.00.702
4 Kraby Automatic 244 mm/100N+Accessories+Guide (1 Set)	372.00.703
5 Kit Kraby Aut355/120N+Accessories+Guide	372.00.707

Each set includes both door and side brackets, fixing screws for both solid and wider aluminium door and instruction sheet.

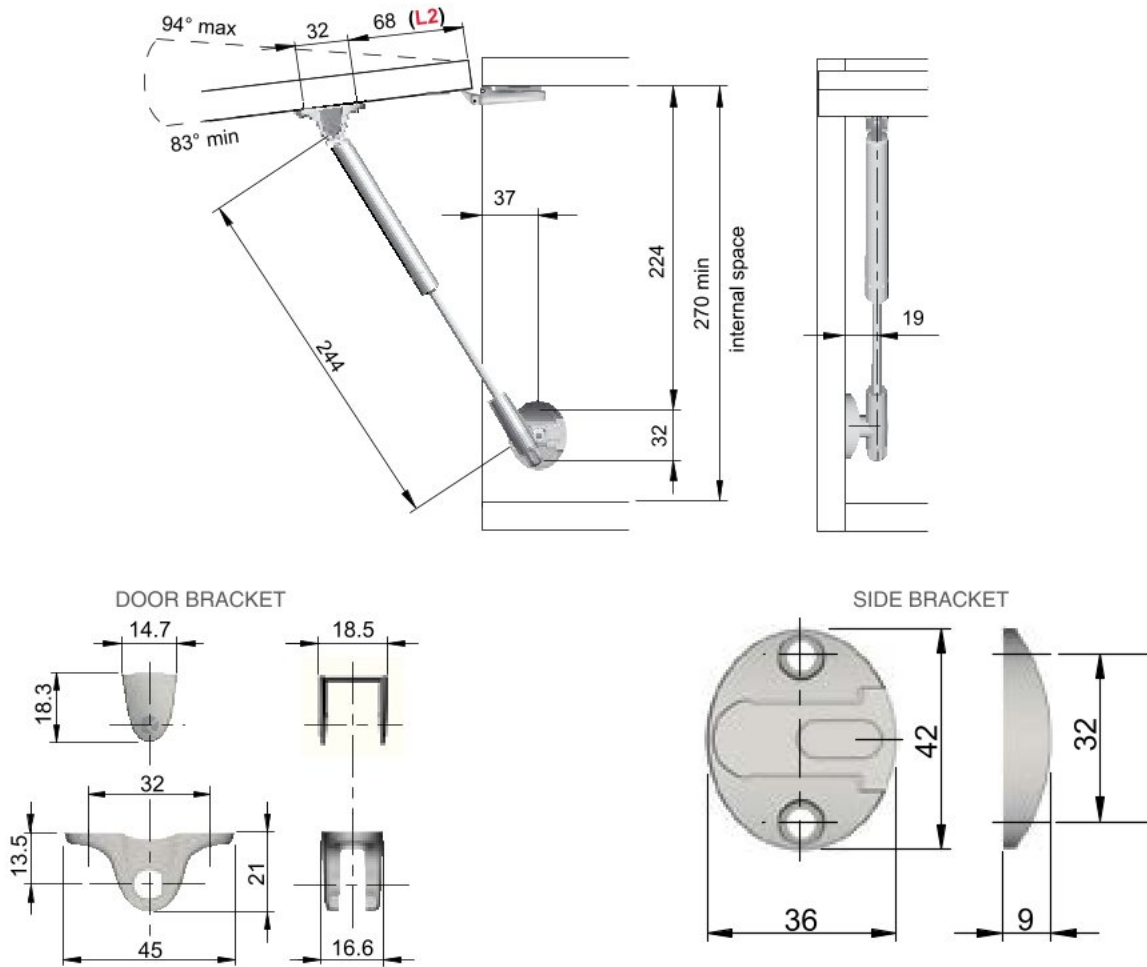

Recommended pre-drilled holes Ø 3 mm.

The dimensions of the above drilling plan refer to carcasses which use standard sprung hinges and mounting plates 0 mm. Please note that min and max opening angle shown data is purely indicative.

It varies with respect to the hinge brand and adjustment carried out.



These are experimental results to be checked by the customer. Our Technical Department is at your disposal to test further cases out of this chart.

Rev. 02

h	Krabby version	Door weight (Kg)													Krabby version
		1	2	3	4	5	6	7	8	9	10	11	12	13	
300 - 324	Automatic	1x80N		2x50N		2x80N		2x100N		2x120N		2x140N		2x160N	Automatic
	Friction	1x45N		1x50N		2x45N		2x60N		2x90N		2x90N		2x90N	Friction
325 - 374	Automatic	1x80N		2x50N		2x80N		2x100N		2x120N		2x140N		2x160N	Automatic
	Friction	1x45N		1x60N		2x45N		2x60N		2x90N		2x90N		2x120N	Friction
375 - 424	Automatic	1x80N	2x50N		2x80N		2x100N		2x120N	2x140N		2x160N	2x180N	2x240N	Automatic
	Friction	1x45N	1x60N				2x60N		2x90N		2x90N				Friction
425 - 474	Automatic		2x50N		2x80N		2x100N		2x120N	2x140N		2x160N	2x180N	3x160N	Automatic
	Friction		1x50N		2x45N		2x60N		2x90N		2x90N		2x120N	3x90N	Friction
475 - 524	Automatic		2x80N		2x100N		2x120N	2x140N		2x160N		2x180N		3x160N	Automatic
	Friction		2x45N			2x60N		2x90N		2x120N		3x90N		3x120N	Friction

Kraby Lift Up

With Standard Unsprung Or Negative Hinges
Automatic opening door with Tip-on

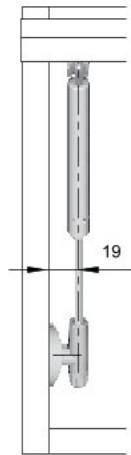
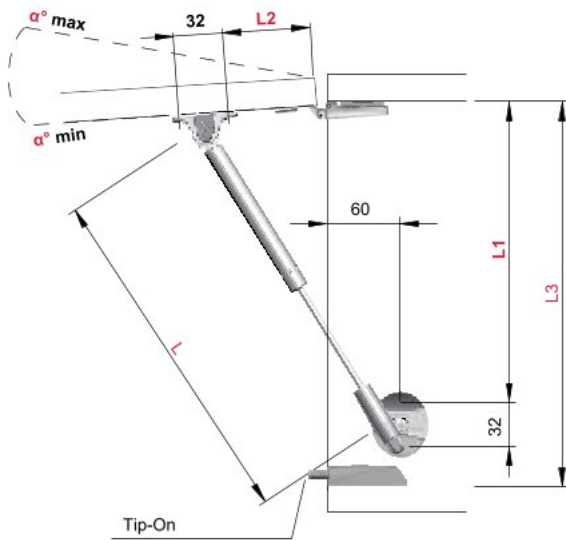

For piston quantity and strength to be specified according to door size, refer to the related Kraby lift up chart.

	L	L1	L2	L3	α° max
					α° min
Kraby 244 mm	244	210	55	260 min	98° max
					80° min

The dimensions of the drilling plan refer to carcasses which use standard unsprung or negative hinges and mounting plates 0 mm. Please note that min and max opening angle shown data is purely indicative. It varies with respect to the hinge brand and adjustment carried out.

Kraby Drop Down



- New design Opening System. Highest quality: each article individually checked and marked
- Available in length 244 mm
- "Zero" N strength, to suit any door dimension and weight
- Smooth and elegant movement to gently open doors down wards
- Open angle adjustment carried out by hand through the rotary knob, for nearby doors alignment
- Adjustment of the piston base plate within the "U" slot of the side bracket to change door opening only
- Quick and easy installation, no need to tension the strength.
- Directly installed on solid or wider aluminium frame doors with wide range of special adapters to suit small aluminium door profiles
- All the parts (stay excluded) are in zinc alloy nickel plated and plastic
- In accordance with Italian Regulation UNI 8607/05 Level 5



1 Kraby 244 mm drop down



ORDERING INFORMATION

Product Description	Article No.
1 Kraby Drop down for Downward opening C/C 244 mm, "zero" N	365.65.700

Each set includes both door and side brackets, fixing screws for both solid and wider aluminium door and instruction sheet.

Kraby Drop Down
 With Standard Sprung Hinges
 Opening With Handle

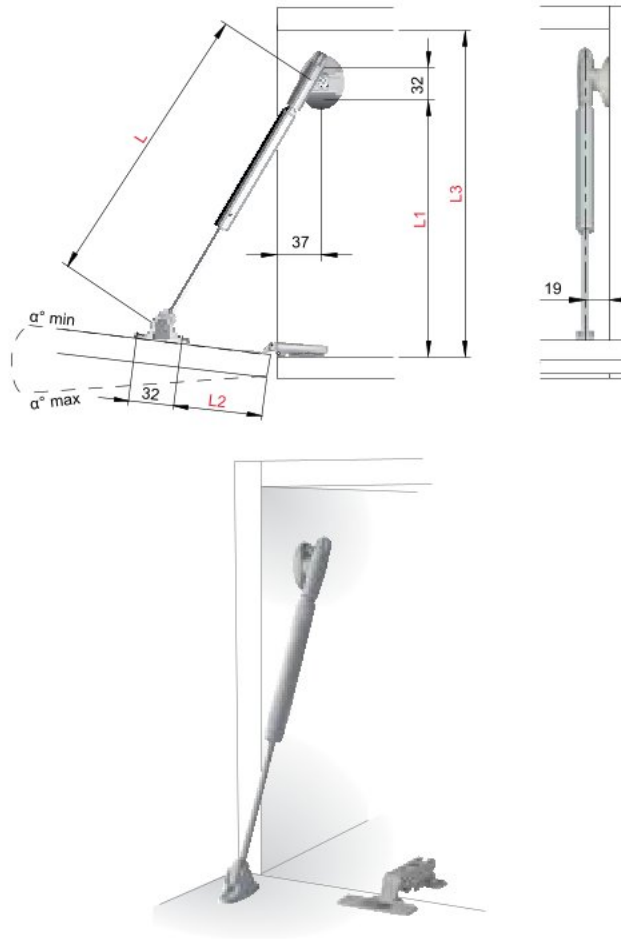

For pistons quantity to be specified according to door size, refer to the related Kraby drop down chart.

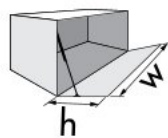

h	W	1200 max.
	Stays	kg
301-350	2 X 244 mm	< 4.9

	L	L1	L2	L3	α° min
					α° max
Kraby 244 mm	244	224	68	270 min	83° min
					94° max

The dimensions of the drilling plan refer to carcasses which use standard sprung hinges and mounting plates 0 mm. Please note that min and max opening angle shown data is purely indicative. It varies with respect to the hinge brand and adjustment carried out.

h	Door weight (kg)												
	1	2	3	4	5	6	7	8	9	10	11	12	13
280-324	2 x Kraby						3 x Kraby					4 x Kraby	
325-424	2 x Kraby						3 x Kraby					4 x Kraby	
425-500	2 x Kraby						3 x Kraby					4 x Kraby	

Kraby Drop Down

With Standard Unsprung Or Negative Hinges
Automatic opening door with Tip-On

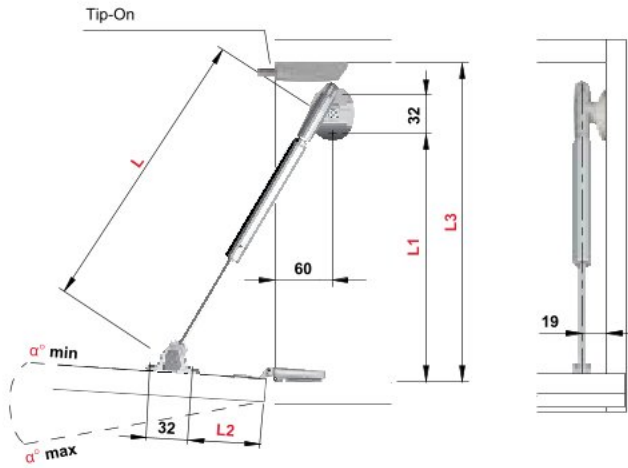

For pistons quantity to be specified according to door size, refer to the related Kraby drop down chart.

	L	L1	L2	L3	α° max
					α° min
Kraby 244 mm	244	210	55	260 min	98° max
					80° min

The dimensions of the drilling plan refer to carcasses which use standard unsprung or negative hinges and mounting plates 0 mm. Please note that min and max opening angle shown data is purely indicative. It varies with respect to the hinge brand and adjustment carried out.

Kraby Drop Down

With Kimana Hinges
Opening with handle and magnet K Lock

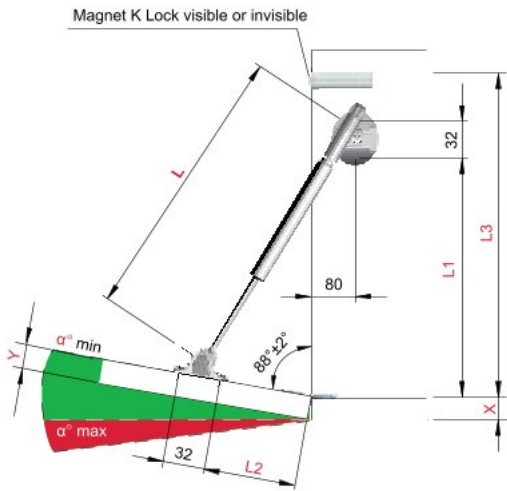

	L	L1	L1	L2	L3	$\alpha^{\circ} \text{ min}$
		X=18 Y= 18	X=19 Y= 19			$\alpha^{\circ} \text{ max}$
Kraby 244 mm	244	197	195	60	245 min	82° min 90° max



OPEN ANGLE ADJUSTMENT:

Kraby provides 10 mm opening angle adjustment through the rotary knob. When you combine Kraby with Kimana hinges, it's strongly recommended to carry out the adjustment to get an opening angle 90° max. Overcrossing 90° door opening angle will negatively effect the Kimana hinges.

VERY IMPORTANT:

- For the case cabinet "X" 18 mm thick and door "Y" 18 mm thick:
- It is required to carry out the 2 mm vertical adjustment on the Kimana hinges.
 - For more details refer to product: Kimana on page no. 123
 - For Kimana hinges at least 2 Kraby lid stays are required for any door width.

Kraby Drop Down
 With Kimana Hinges
 Automatic opening door with Tip-On

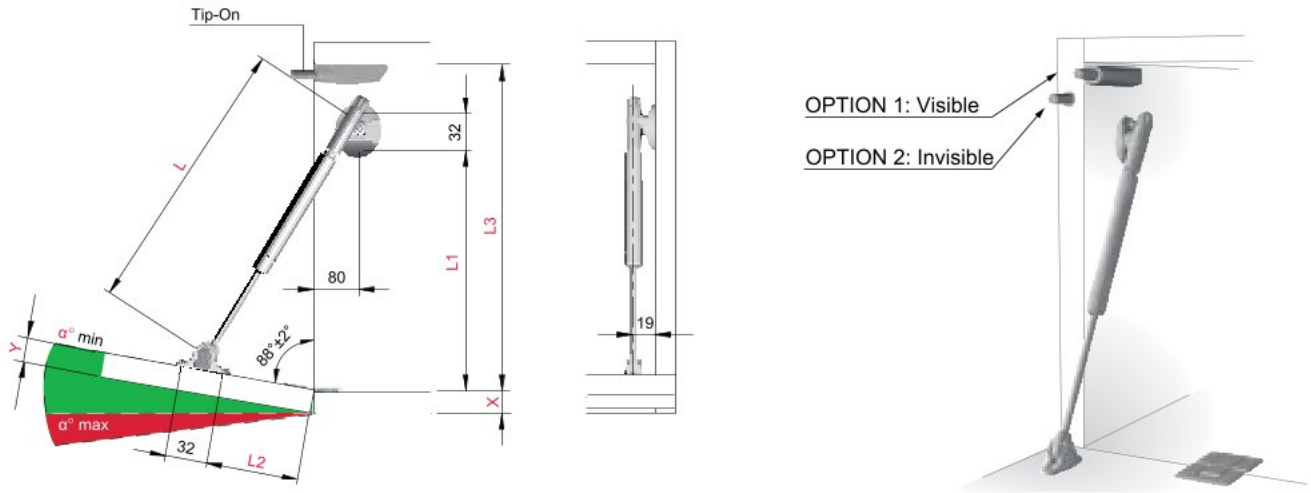

For pistons quantity to be specified according to door size, refer to the related Kraby drop down chart.

	L	L1 X=18 Y=18	L1 X=19 Y=19	L2	L3	α° max
						α° min
Kraby 244 mm	244	197	195	60	245 min	82° max
						90° min



OPEN ANGLE ADJUSTMENT:

Kraby provides 10 mm opening angle adjustment through the rotary knob. While combining Kraby with Kimana hinges, it's strongly recommended to carry out the adjustment to get an opening angle 90° max. Overcrossing 90° door opening angle will negatively effect the Kimana hinges.

VERY IMPORTANT:

- For the case cabinet "X" 18 mm thick and door "Y" 18 mm thick:
- It is required to carry out the 2 mm vertical adjustment on the Kimana hinges.
- For more details refer to product: Kimana on page no. 123
- For different cabinet and door thickness, please contact the office.
- For Kimana hinges at least 2 Kraby lid stays are required for any door width.

K12 Drop Down

- Thanks to the reduced size and minimal design, the K12 System provides a new concept of elegance in all details
- “Zero” N strength, to suit any door dimension and weight
- It is an easy-to-install solution that makes additional screws unnecessary, improving the aesthetic and reducing assembling time
- It operates through click-in-door and side supports, sensibly reducing the risk of unsafe or improper installation
- Length 244 mm & 355 mm
- All parts (stay excluded) are in zinc alloy nickel plated, steel and engineering plastic
- In accordance with Italian Regulation UNI 8607/05 Level 5



ORDERING INFORMATION

Product Description		Article No.
1	K12 drop down New 244 + Acc. +Guide	365.60.700
2	K12 drop down New 355 + Acc. +Guide	274.50.951

Each set includes both Ø15mm door and side brackets and instruction sheet.

K12 Drop Down
 With Standard Sprung Hinges
 Opening with handle

DRILLING PLAN WITH BRACKETS Ø 15mm

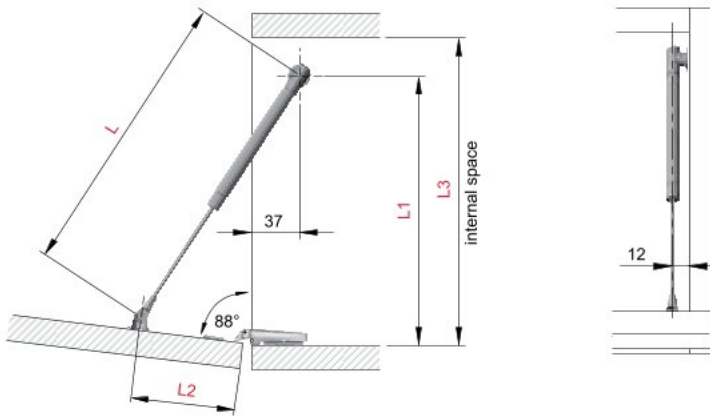

DOOR BRACKET Ø15 mm

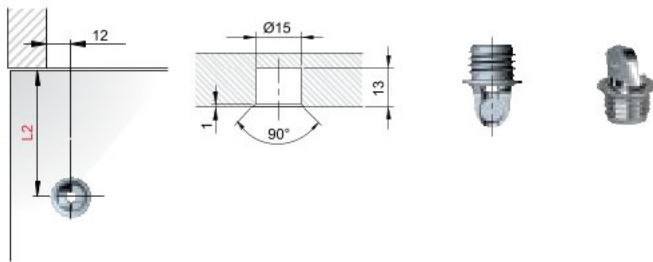

SIDE BRACKET Ø15 mm

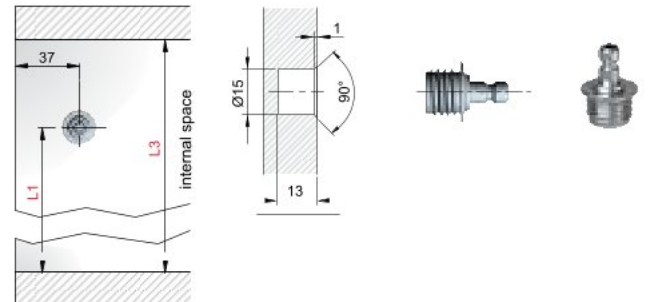

h	DOOR WEIGHT (kg)																	
	1	2	3	4	5	6	7	8	9	10	11	12	13	14	15	16	17	18
300	1 x K12			2 x K12			3 x K12			4 x K12								
350	1 x K12		2 x K12		3 x K12				4 x K12									
400	1 x K12	2 x K12		3 x K12			4 x K12											
450	1 x K12	2 x K12		3 x K12		4 x K12												
500	1 x K12	2 x K12		3 x K12		4 x K12												

For pistons quantity to be specified according to door size, refer to related K12 drop down chart.

	L	L1	L2	L3 Ø 15 m 
K12 System 244 mm	244	230	76	250 min

The dimensions of the above drilling plan refer to carcasses which use standard sprung hinges and mounting plates 0 mm. Please note that the opening angle shown data is purely indicative. It varies with respect to the hinge brand and adjustment carried out.

K12 Drop Down

With Standard Unsprung Or Negative Hinges
Automatic opening door with Tip-On

DRILLING PLAN WITH BRACKETS Ø 15mm

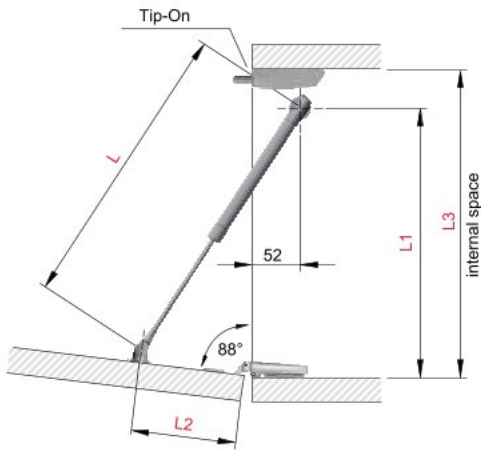



OPTION 1: Visible

OPTION 2: Invisible



For pistons quantity to be specified according to door size, refer to related K12 drop down chart.

	L	L1	L2	L3 Ø15 mm 	L3 screw fix 
K12 System 244 mm	244	224	71	245 min	259 min

The dimensions of the above drilling plan refer to carcasses which use standard unsprung or negative hinges and mounting plates 0 mm.

Please note that the opening angle shown data is purely indicative. It varies with respect to the hinge brand and adjustment carried out.

K12 Drop Down
With Kimana Hinges Opening
With Handle and Magnet K Lock

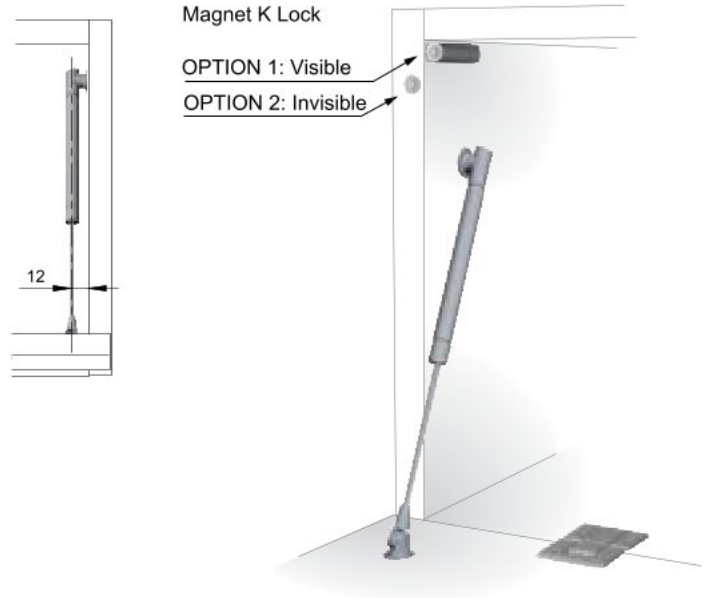
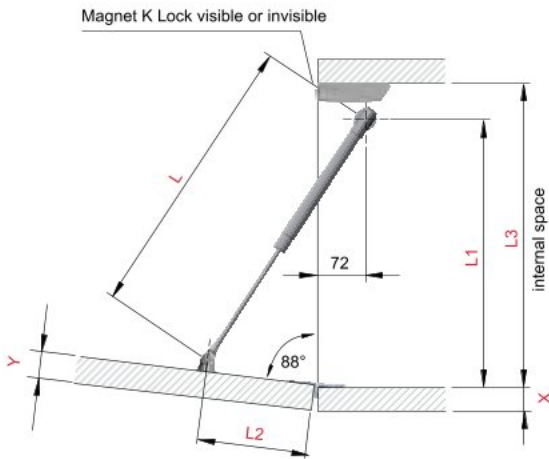

DOOR BRACKET Ø15 mm

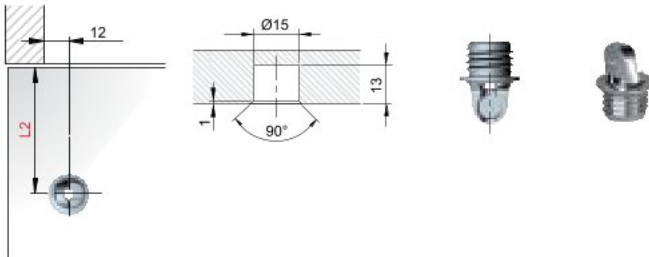

SIDE BRACKET Ø15 mm

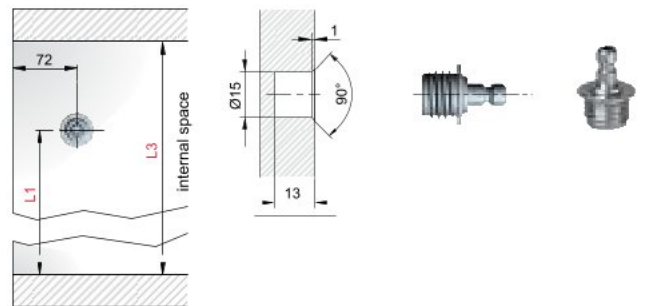

For pistons quantity to be specified according to door size, refer to related K12 drop down chart.

	L	L1 X=18 Y=18	L1 X=19 Y=19	L2	L3 Ø 15 m 
K12 System 244 mm	244	208	206	76	225 min

VERY IMPORTANT:

- For the case cabinet "X" 18 mm and door "Y" 18 mm thick:
- It is required to carry out the 2 mm vertical adjustment on the Kimana hinges.
- For more details refer to product: KIMANA on page no. 123

- For different cabinet and door thickness, please contact the office.
- For Kimana hinges at least 2 K12 lid stays are required for any door width.

K12 Drop Down
 With Kimana Hinges
 Automatic opening door with Tip-On

DRILLING PLAN WITH BRACKETS Ø 15mm

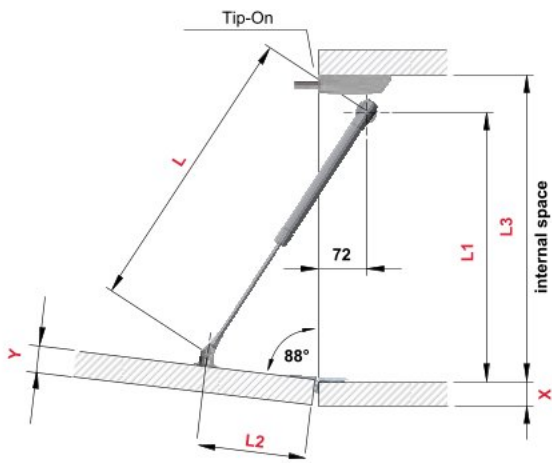

For pistons quantity to be specified according to door size, refer to related K12 drop down chart.

	L	L1 X=18 Y=18	L1 X=19 Y=19	L2	L3 Ø15 mm 
K12 System 244 mm	244	208	206	76	225 min

VERY IMPORTANT:

- For the case cabinet "X" 18 mm and door "Y" 18 mm thick:
- It is required to carry out the 2 mm vertical adjustment on the Kimana hinges.
 - For more details refer to product: KIMANA on page no. 123

- For different cabinet and door thickness, please contact the office.
- For Kimana hinges at least 2 K12 lid stays are required for any door width.

HINGES



Metalla 510 105° Standard Application Hinges

- With integrated soft closing mechanism in hinge cup
- The soft closing mechanism can be activated at an opening angle of 30° or 10° via damper shifter

- **Material:** Steel: Cup and hinge arm
- **Finish:** Nickel plated
- **Cup fixing:** For screw fixing
- **Installation:** Door to cabinet for quick fixing with SM quick fixing system
- **Drilling depth:** Hinge cup 12 mm
- **Adjustment facility:** Side adjustment -1.5 to +3 mm, height adjustment -2 to +2 mm, depth adjustment with mounting plate +2.8 mm
- **Opening angle:** 105°
- **Door thickness:** 15-24 mm



1 Full Overlay mounting



2 Half Overlay mounting



3 Inset mounting

ORDERING INFORMATION

Product Description	Article No.
1 Metalla 510 105° Full Overlay Hinge, Drilling Pattern 48/6	311.46.591
2 Metalla 510 105° Half Overlay Hinge, Drilling Pattern 48/6	311.46.590
3 Metalla 510 105° Inset Hinge, Drilling Pattern 48/6	311.46.592

Metalla 510 155° Wide Angle Hinge for Cabinets with Internal Drawers or Shelves



- 0-door offset for use with internal pull outs or extending trays
- With integrated soft closing mechanism in hinge cup
- **Material:** Zinc alloy: cup, steel: hinge arm
- **Finish:** Nickel plated
- **Cup fixing:** For screw fixing
- **Installation:** Door to cabinet for quick fixing with SM quick fixing system
- **Drilling depth:** Hinge cup with soft closing mechanism:13.5 mm
- **Adjustment facility:** Side adjustment -1.5 to +4.5 mm, height adjustment -2 to +2 mm, depth adjustment with mounting plate +2.8 mm
- **Opening angle:** 155°
- **Door thickness:** 16-28 mm

ORDERING INFORMATION

Product Description	Article No.
 Metalla 510 155° Full Overlay Wide Angle Hinge, Drilling Pattern 48/6	311.46.594

Metalla 510 105° Narrow Aluminium Profile Hinge (For Frame Width:19 mm)

- With two silicone oil dampers integrated in hinge cup
- **Material:** Zinc alloy: cup, steel: hinge arm
- **Finish:** Nickel plated
- **Cup fixing:** For screw fixing
- **Installation:** Door to cabinet for quick fixing with SM quick fixing system
- **Drilling depth:** Hinge cup 12.5 mm
- **Adjustment facility:** Side adjustment from -1.5 to +4.5 mm (via Hinge), height adjustment 2 mm (via Mounting Plate), depth adjustment upto 2.8 mm (via mounting plate)
- **Opening angle:** 105°
- **Door thickness:** 20 mm



ORDERING INFORMATION

Product Description	Article No.
 Metalla 510 105° Narrow Aluminium Profile Hinge (For Frame Width: 19 mm)	311.46.593

Cover Caps for Metalla 510 SM



- **Material:** Steel
- **Finish:** Nickel plated
- **Suitable for:** 105° concealed hinges

Distance D mm	Article. No.
Cover Cap for Hinge Cup	329.32.630
Cover Cap for Hinge Arm	329.32.640

Metalla 510 110° Standard Application Hinges



- With integrated soft closing mechanism in hinge cup
- The soft closing mechanism can be activated at an opening angle of 30° or 10° via damper shifter
- **Material:** Steel cup and Zinc alloy hinge arm
- **Finish:** Nickel plated
- **Cup fixing:** For screw fixing
- **Installation:** Door to cabinet for quick fixing with SM quick fixing system
- **Drilling depth:** Hinge cup with soft closing mechanism: 13.5 mm
- **Adjustment facility:** Side adjustment -1.5 to +4.5 mm, height adjustment -2 to +2 mm, depth adjustment with mounting plate +2.8 mm
- **Opening angle:** 110°
- **Door thickness:** 16-26 mm



1 Full overlay mounting



2 Half overlay mounting/twin mounting



3 Inset mounting

ORDERING INFORMATION

	Standard Set	Article. No.
1	Metalla 510 110° Full Overlay Hinge, Drilling Pattern 48/6	329.13.451
2	Metalla 510 110° Half Overlay Hinge, Drilling Pattern 48/6	329.13.452
3	Metalla 510 110° Inset Hinge, Drilling Pattern 48/6	329.13.453

* Set contains 1 hinge, 1 mounting Plate

Metalla 510 94° Profile Door Hinge Sets for Standard Application

- With integrated soft closing mechanism in hing cup
- The soft closing mechanism can be activated at an opening angle of 30° or 10° via damper shifter
- **Material:** Steel cup and Zinc alloy hinge arm
- **Finish:** Nickel plated
- **Cup fixing:** For screw fixing
- **Installation:** Door to cabinet for quick fixing with SM quick fixing system
- **Drilling depth:** Hinge cup 11 mm
- **Adjustment facility:** Side adjustment -1.5 to +4.5 mm, height adjustment -2 to +2 mm, depth adjustment with mounting plate +2.8 mm
- **Opening angle:** 94°
- **Door thickness:** 19-35 mm



1 Full overlay mounting



2 Half overlay mounting/twin mounting



3 Inset mounting

ORDERING INFORMATION

	Standard Set	Article. No.
1	Metalla 510 94° Profile door Hinge Full Overlay with 3mm Straight Mounting plate, Drilling Pattern 48/6	329.19.000
	Metalla 510 94° Profile door Hinge Full Overlay with 0mm Straight Mounting plate, Drilling Pattern 48/6	329.19.003
	Metalla 510 94° Profile door Hinge Full Overlay with 3mm Cruciform Mounting plate, Drilling Pattern 48/6	329.19.006
	Metalla 510 94° Profile door Hinge Full Overlay with 0mm Cruciform Mounting plate, Drilling Pattern 48/6	329.19.009
2	Metalla 510 94° Profile door Hinge Half Overlay with 3mm Straight Mounting plate, Drilling Pattern 48/6	329.19.001
	Metalla 510 94° Profile door Hinge Half Overlay with 0mm Straight Mounting plate, Drilling Pattern 48/6	329.19.004
	Metalla 510 94° Profile door Hinge Half Overlay with 3mm Cruciform Mounting plate, Drilling Pattern 48/6	329.19.007
	Metalla 510 94° Profile door Hinge Half Overlay with 0mm Cruciform Mounting plate, Drilling Pattern 48/6	329.19.010
3	Metalla 510 94° Profile door Hinge Inset mounting with 3mm Straight Mounting plate, Drilling Pattern 48/6	329.19.002
	Metalla 510 94° Profile door Hinge Inset mounting with 0mm Straight Mounting plate, Drilling Pattern 48/6	329.19.005
	Metalla 510 94° Profile door Hinge Inset mounting with 3mm Cruciform Mounting plate, Drilling Pattern 48/6	329.19.008
	Metalla 510 94° Profile door Hinge Inset mounting with 0mm Cruciform Mounting plate, Drilling Pattern 48/6	329.19.011

* Set contains 1 hinge, 1 mounting Plate

Metalla 510 110° Blind Corner Hinge Sets



- With integrated soft closing mechanism in hinge cup
- The soft closing mechanism can be activated at an opening angle of 30° or 10° via damper shifter
- **Material:** Steel cup and Zinc alloy hinge arm
- **Finish:** Nickel plated
- **Cup fixing:** For screw fixing
- **Installation:** Door to cabinet for quick fixing with SM quick fixing system
- **Drilling depth:** Hinge cup 13.5 mm
- **Adjustment facility:** Side adjustment upto +4.5 mm, height adjustment -2 to +2 mm, depth adjustment with mounting plate +2.8 mm
- **Opening angle:** 110° Blind Corners
- **Door thickness:** 16-26 mm

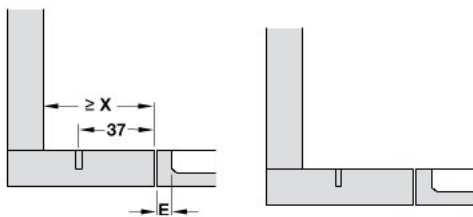

1

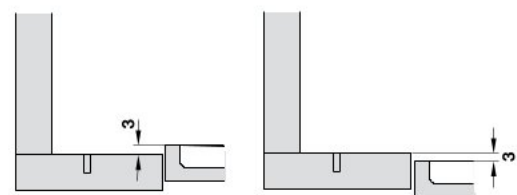

2

X max:
 For Duomatic A = 61 mm
 For Duomatic SM = 70 mm
 For Duomatic SM with rear eccentric = 74 mm
 Distance to cup E = 3 to 6 mm
 Y = 37 mm with joint F = 1 mm and cup distance E = 3 mm

ORDERING INFORMATION

	Standard Set	Article. No.
1	Metalla 510 110° Blind Corner Hinge with 3 mm Straight Mounting plate, Drilling Pattern 48/6	329.13.450
	Metalla 510 110° Blind Corner Hinge with 0mm Straight Mounting plate, Drilling Pattern 48/6	329.19.036
2	Metalla 510 110° Blind Corner Hinge with 3mm Cruciform Mounting plate, Drilling Pattern 48/6	329.19.037
	Metalla 510 110° Blind Corner Hinge with 0mm Cruciform Mounting plate, Drilling Pattern 48/6	329.19.038

* Set contains 1 hinge, 1 mounting Plate

Metalla 510 45° Hinge Sets for Corner Application

- With integrated soft closing mechanism in hinge cup
- The soft closing mechanism can be activated at an opening angle of 30° or 10° via damper shifter
- **Material:** Steel cup and Zinc alloy hinge arm
- **Finish:** Nickel plated
- **Cup fixing:** For screw fixing
- **Installation:** Door to cabinet for quick fixing with SM quick fixing system
- **Drilling depth:** Hinge cup 13.5 mm
- **Adjustment facility:** Side adjustment upto +4.5 mm, height adjustment -2 to +2 mm, depth adjustment with mounting plate +2.8 mm
- **Opening angle:** 45° Corner
- **Door thickness:** 16-26 mm



1 45° Corner application, overlay



2 45° Corner application, half overlay



3 45° Corner application, for flush front panels

ORDERING INFORMATION

	Standard Set	Article. No.
1	Metalla 510 45° Corner Hinge Full Overlay with 3mm Straight Mounting plate, Drilling Pattern 48/6	329.13.454
	Metalla 510 45° Corner Hinge Full Overlay with 3mm Cruciform Mounting plate, Drilling Pattern 48/6	329.19.045
	Metalla 510 45° Corner Hinge Full Overlay with 0mm Cruciform Mounting plate, Drilling Pattern 48/6	329.19.048
2	Metalla 510 45° Corner Hinge Half Overlay with 3mm Straight Mounting plate, Drilling Pattern 48/6	329.13.455
	Metalla 510 45° Corner Hinge Half Overlay with 3mm Cruciform Mounting plate, Drilling Pattern 48/6	329.19.046
	Metalla 510 45° Corner Hinge Half Overlay with 0mm Cruciform Mounting plate, Drilling Pattern 48/6	329.19.049
3	Metalla 510 45° Corner Hinge Inset mounting with 3mm Straight Mounting plate, Drilling Pattern 48/6	329.13.456
	Metalla 510 45° Corner Hinge Inset mounting with 3mm Cruciform Mounting plate, Drilling Pattern 48/6	329.19.047
	Metalla 510 45° Corner Hinge Inset mounting with 0mm Cruciform Mounting plate, Drilling Pattern 48/6	329.19.050

* Set contains 1 hinge, 1 mounting Plate

Metalla 510 110° Push Hinge Sets for Standard Application



- Automatic opening, almost completely opens the door
- With reverse spring on the hinge arm
- **Material:** Steel cup and Zinc alloy hinge arm
- **Finish:** Nickel plated
- **Cup fixing:** For screw fixing
- **Installation:** Door to cabinet for quick fixing with SM quick fixing system
- **Drilling depth:** Hinge cup 11 mm
- **Adjustment facility:** Side adjustment -1.5 to +4.5 mm, height adjustment -2 to +2 mm, depth adjustment with mounting plate +2.8 mm
- **Opening angle:** 110°
- **Door thickness:** 16-26 mm



1 Full overlay mounting



2 Half overlay mounting/twin mounting

ORDERING INFORMATION

Standard Set		Article. No.
1	Metalla 510 110° Push Hinge Full Overlay with 3mm Straight Mounting plate, Drilling Pattern 48/6	329.19.012
	Metalla 510 110° Push Hinge Full Overlay with 0mm Straight Mounting plate, Drilling Pattern 48/6	329.19.014
	Metalla 510 110° Push Hinge Full Overlay with 3mm Cruciform Mounting plate, Drilling Pattern 48/6	329.19.016
	Metalla 510 110° Push Hinge Full Overlay with 0mm Cruciform Mounting plate, Drilling Pattern 48/6	329.19.018
2	Metalla 510 110° Push Hinge Half Overlay with 3mm Straight Mounting plate, Drilling Pattern 48/6	329.19.013
	Metalla 510 110° Push Hinge Half Overlay with 0mm Straight Mounting plate, Drilling Pattern 48/6	329.19.015
	Metalla 510 110° Push Hinge Half Overlay with 3mm Cruciform Mounting plate, Drilling Pattern 48/6	329.19.017
	Metalla 510 110° Push Hinge Half Overlay with 0mm Cruciform Mounting plate, Drilling Pattern 48/6	329.19.019

* Set contains 1 hinge, 1 mounting Plate

Metalla 510 110° Unsprung Hinge Sets for Standard Application

- Springless Hinge
- **Material:** Steel cup and Zinc alloy hinge arm
- **Finish:** Nickel plated
- **Cup fixing:** For screw fixing
- **Installation:** Door to cabinet for quick fixing with SM quick fixing system
- **Drilling depth:** Hinge cup 11 mm
- **Adjustment facility:** Side adjustment -1.5 to +4.5 mm, height adjustment -2 to +2 mm, depth adjustment with mounting plate +2.8 mm
- **Opening angle:** 110°
- **Door thickness:** 16-26 mm



1 Full overlay mounting



2 Half overlay mounting/twin mounting

ORDERING INFORMATION

	Standard Set	Article. No.
1	Metalla 510 110° Unsprung Hinge Full Overlay with 3mm Straight Mounting plate, Drilling Pattern 48/6	329.19.020
	Metalla 510 110° Unsprung Hinge Full Overlay with 0mm Straight Mounting plate, Drilling Pattern 48/6	329.19.022
	Metalla 510 110° Unsprung Hinge Full Overlay with 3mm Cruciform Mounting plate, Drilling Pattern 48/6	329.19.024
	Metalla 510 110° Unsprung Hinge Full Overlay with 0mm Cruciform Mounting plate, Drilling Pattern 48/6	329.19.026
2	Metalla 510 110° Unsprung Hinge Half Overlay with 3mm Straight Mounting plate, Drilling Pattern 48/6	329.19.021
	Metalla 510 110° Unsprung Hinge Half Overlay with 0mm Straight Mounting plate, Drilling Pattern 48/6	329.19.023
	Metalla 510 110° Unsprung Hinge Half Overlay with 3mm Cruciform Mounting plate, Drilling Pattern 48/6	329.19.025
	Metalla 510 110° Unsprung Hinge Half Overlay with 0mm Cruciform Mounting plate, Drilling Pattern 48/6	329.19.027

* Set contains 1 hinge, 1 mounting Plate

Metalla 510 165° Sprung Hinge Sets for Standard Application



- 0-door offset for use with internal pull outs or extending trays
- **Material:** Steel cup and Zinc alloy hinge arm
- **Finish:** Nickel plated
- **Cup fixing:** For screw fixing
- **Installation:** Door to cabinet for quick fixing with SM quick fixing system
- **Drilling depth:** Hinge cup 11 mm
- **Adjustment facility:** Side adjustment -1.5 to +4.5 mm, height adjustment -2 to +2 mm, depth adjustment with mounting plate +2.8 mm
- **Opening angle:** 165°
- **Door thickness:** 16-26 mm



1 Metalla 510 165° Sprung Hinge

ORDERING INFORMATION

Standard Set		Article. No.
1	Metalla 510 165° Sprung Hinge Full Overlay with 3mm Straight Mounting plate, Drilling Pattern 48/6	329.19.028
	Metalla 510 165° Sprung Hinge Full Overlay with 0mm Straight Mounting plate, Drilling Pattern 48/6	329.19.030
	Metalla 510 165° Sprung Hinge Full Overlay with 3mm Cruciform Mounting plate, Drilling Pattern 48/6	329.19.032
	Metalla 510 165° Sprung Hinge Full Overlay with 0mm Cruciform Mounting plate, Drilling Pattern 48/6	329.19.034
2	Metalla 510 165° Sprung Hinge Half Overlay with 3mm Straight Mounting plate, Drilling Pattern 48/6	329.19.029
	Metalla 510 165° Sprung Hinge Half Overlay with 0mm Straight Mounting plate, Drilling Pattern 48/6	329.19.031
	Metalla 510 165° Sprung Hinge Half Overlay with 3mm Cruciform Mounting plate, Drilling Pattern 48/6	329.19.033
	Metalla 510 165° Sprung Hinge Half Overlay with 0mm Cruciform Mounting plate, Drilling Pattern 48/6	329.19.035

* Set contains 1 hinge, 1 mounting Plate

Metalla 510 110° Midnight Black Standard Application Hinge

- With integrated soft closing mechanism in hinge cup
- The soft closing mechanism can be activated at an opening angle of 30° or 10° via damper shifter
- **Material:** Steel cup and Zinc alloy hinge arm
- **Finish:** Midnight black
- **Cup fixing:** For screw fixing
- **Installation:** Door to cabinet for quick fixing with SM quick fixing system
- **Drilling depth:** Hinge cup 13.5 mm
- **Adjustment facility:** Side adjustment -1.5 to +4.5 mm, height adjustment -2 to +2 mm, depth adjustment with mounting plate +2.8 mm
- **Opening angle:** 110°
- **Door thickness:** 16-26 mm



1 Full overlay mounting



2 Half overlay mounting/twin mounting



3 Inset mounting

ORDERING INFORMATION

Standard Set		Article. No.
1	Metalla 510 110° Midnight Black Full Overlay Hinge, Drilling Pattern 48/6	329.19.051
2	Metalla 510 110° Midnight Black Half Overlay Hinge, Drilling Pattern 48/6	329.19.052
3	Metalla 510 110° Midnight Black Inset Hinge, Drilling Pattern 48/6	329.19.053

* Set contains 1 hinge, 1 mounting plate, 1 hinge arm cover cap, 1 hinge cup cover cap

Metalla 510 155° Midnight Black Hinge Sets for Standard Application



- With or without soft close integrated into the hinge cup.
- 0-door offset for use with internal pull outs or extending trays
- **Material:** Steel cup and Zinc alloy hinge arm
- **Finish:** Midnight black
- **Cup fixing:** For screw fixing
- **Installation:** Door to cabinet for quick fixing with SM quick fixing system
- **Drilling depth:** 13.5 mm for soft close hinge and 11mm for sprung hinge
- **Adjustment facility:** Side adjustment -1.5 to +4.5 mm, height adjustment -2 to +2 mm, depth adjustment with mounting plate +2.8 mm
- **Opening angle:** 155°
- **Door thickness:** 16-26 mm



1 Full overlay mounting

ORDERING INFORMATION

Standard Set		Article. No.
1	Metalla 510 155° Zero Potrusion Soft Close Hinge, Midnight Black Full Overlay Drilling Pattern 48/6	329.19.054
	Metalla 510 155° Zero Potrusion Sprung Hinge, Midnight Black Full Overlay Drilling Pattern 48/6	329.19.055

* Set contains 1 hinge, 1 mounting plate, 1 hinge arm cover cap, 1 hinge cup cover cap

Metalla 510 94° Thick Door Midnight Black Standard Application Hinges

- With integrated soft closing mechanism in hinge cup
- The soft closing mechanism can be activated at an opening angle of 30° or 10° via damper shifter.
- **Material:** Steel cup and Zinc alloy hinge arm
- **Finish:** Midnight black
- **Cup fixing:** For screw fixing
- **Installation:** Door to cabinet for quick fixing with SM quick fixing system
- **Drilling depth:** Hinge cup 13.5 mm
- **Adjustment facility:** Side adjustment -1.5 to +4.5 mm, height adjustment -2 to +2 mm, depth adjustment with mounting plate +2.8 mm
- **Opening angle:** 94°
- **Door thickness:** 19-35 mm



1 Full overlay mounting

ORDERING INFORMATION

Standard Set	Article. No.
1 Metalla 510 94° Thick Door Midnight Black Full Overlay Hinge, Drilling Pattern 48/6	329.19.056

* Set contains 1 hinge, 1 mounting plate,
1 hinge arm cover cap, 1 hinge cup cover cap

Metalla 510 94° Thick Door Midnight Black Unsprung Hinge



- Springless Hinge
- They can be used in combination with PTO triggers with magnet
- **Material:** Steel cup and Zinc alloy hinge arm
- **Finish:** Midnight Black
- **Cup fixing:** For screw fixing
- **Installation:** Door to cabinet for quick fixing with SM quick fixing system
- **Drilling depth:** Hinge cup 11 mm
- **Adjustment facility:** Side adjustment -1.5 to +4.5 mm, height adjustment -2 to +2 mm, depth adjustment with mounting plate +2.8 mm
- **Opening angle:** 94°
- **Door thickness:** 19-35 mm



1 Full overlay mounting

ORDERING INFORMATION

Standard Set	Article. No.
1 Metalla 510 94° Thick door Midnight Black Full Overlay Hinge, Drilling Pattern 48/6	329.19.057

* Set contains 1 hinge, 1 mounting plate, 1 hinge arm cover cap, 1 hinge cup cover cap

Push To Open Triggers and Adapters

Push-to-Open Triggers come with a fresh captivating design and enable automatic opening for doors without handles or knobs with just a slight push. These mechanisms provide silent, yet powerful operations, granting long-term durability which make them perfectly suitable for a wide range of doors. They come with extensive spring strengths that guarantee their flawless functioning even with large and heavy doors. Tested for 80,000 cycles, certified by CATAS, the triggers are available with buffer for cabinets using sprung / soft close hinges, and with magnet for cabinets using unsprung or reverse-spring hinges.

- **Output path lengths:** Short (20 mm) and Long (37 mm)
- **Installation possibilities:** Concealed or visible, fixed with adapter housing
- **Finishes:** Anthracite, Grey and White
- **Gap between door and cabinet:** Activation gap is 1.4 mm, ring thickness is 0.6 mm.
- **Adjustment:** +6 / -0.45 mm. Beyond this negative adjustment the spring is deactivated. This feature allows to disable the ejector pin for safety reasons



Versions



Adapters



ORDERING INFORMATION

Colour	Push to Open Triggers			
	With Magnet*		With Buffer	
	20mm	37mm	20mm	37mm
Anthracite	356.12.362	356.12.308	356.12.613	356.12.317
White	356.12.762	356.12.708	356.12.612	356.12.717
Grey	356.12.562	356.12.508	356.12.614	356.12.517
	Trigger Adapters			
	20mm		37mm	
Anthracite	356.12.334		356.12.324	
White	356.12.734		356.12.724	
Grey	356.12.534		356.12.524	

* Comes with door catch plates

Unit: 1 Set

Metalla Clip-On Hinges (with Soft-Close)



Soft Closing Damper Hinge

- Soft Close integrated into hinge arm
- Clip-on Mounting
- **Material:** Mild steel
- **Finish:** Nickel plated
- **Cycle testing:** Passed 40,000 cycles
- Passed 48 hour salt test
- Material certified according to TUV Germany
- 3 Dimensional adjustment facility

Technical Information:

- **Opening angle:** 110°
- **Thickness of hinge cup:** 11.3 mm
- **Diameter of hinge cup:** 35 mm
- **Door thickness:** 14-22 mm

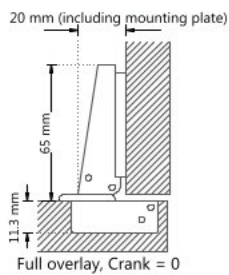

1 Full overlay mounting

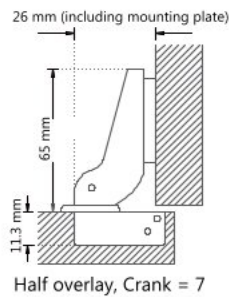

2 Half overlay mounting

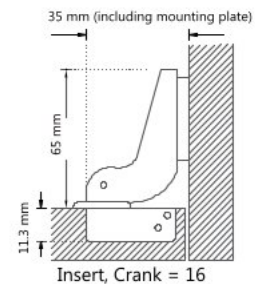

3 Inset mounting

Note:

- Not suitable for undersink application
- Article consists of 2 Hinges+2 Mounting Plates+ 8 fixing screws

ORDERING INFORMATION

Product Description		Article No.
1	Metalla Soft Close Hinge 110° Full Overlay	315.07.075
2	Metalla Soft Close Hinge 110° Half Overlay	315.07.076
3	Metalla Soft Close Hinge 110° Inset Overlay	315.07.077

Metalla Slide-On Hinges (with Soft-Close)

- Slide-on Mounting
- **Material:** Mild steel
- **Finish:** Nickel plated
- **Cycle testing:** Passed 40,000 cycles
- Passed 48 hours salt spray test
- 3-Dimensional adjustment

Technical Information:

- **Opening angle:** 105°
- **Thickness of hinge arm:** 11.3 mm
- **Diameter of hinge cup:** 35 mm
- **Door thickness:** 14-22 mm
- **Drilling pattern:** 48/6 mm

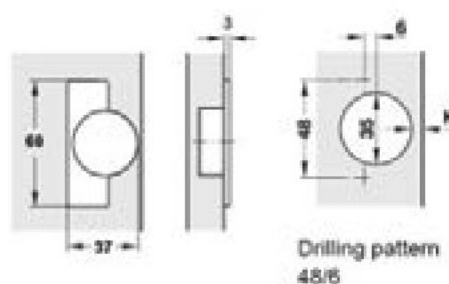
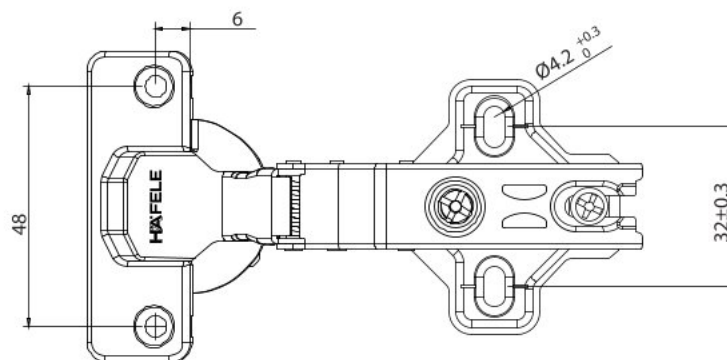

Note:

- Not suitable for undersink application
- Article consists of 2 hinges + 2 mounting plates + 8 screws

ORDERING INFORMATION

Product Description	Article No.
1 Slide on Soft Close Hinge Full Overlay	315.07.042
2 Slide on Soft Close Hinge Half Overlay	315.07.043
3 Slide on Soft Close Hinge Inset	315.07.044

Metalla Clip-On Hinges (with 4 Holes Mounting Plate)



- Mounting Plate with 4 holes for extra stability
- Clip-on Mounting
- **Material:** Mild steel
- **Finish:** Nickel plated
- **Cycle testing:** Passed 40,000 cycles
- Passed 48 hours salt spray test
- 3-Dimensional adjustment

Technical Information:

- **Opening angle:** 110°
- **Thickness of hinge arm:** 11.3 mm
- **Door thickness:** 14-22 mm
- **Drilling pattern:** A= 48 mm & B = 6 mm

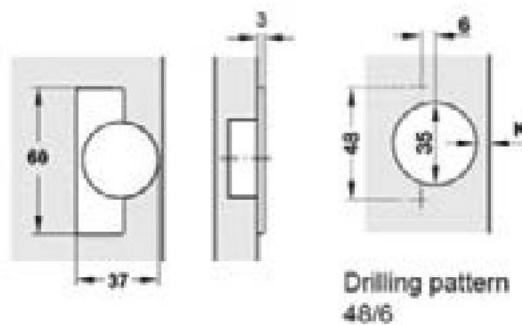
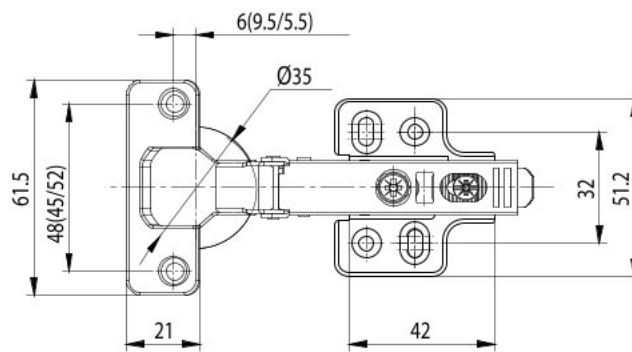

Note:

- Not suitable for undersink application
- Article consists of 2 hinges + 2 mounting plates + 12 screws

ORDERING INFORMATION

Product Description	Article No.
1 Clip-On Metalla 0 Crank 4 Hole MP	311.01.146
2 Clip-On Metalla Half Crank 4 Hole MP	311.01.145
3 Clip-On Metalla Inset Crank 4 Hole MP	311.01.144

Metalla Slide-On Hinges (with 4 Holes Mounting Plate)

- Slide-on hinges with automatic closing spring with 3 dimensional adjusting facility.

Technical Information:

- **Opening angle:** 110°
- **Door thickness:** 14-22 mm
- **Finish:** Nickel plate
- **Material:** Mild steel
- **Mounting plate:** 4 hole

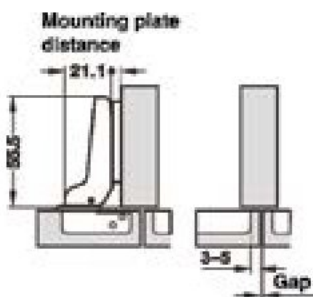

1 Full overlay mounting

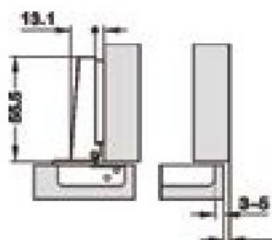

2 Half overlay mounting

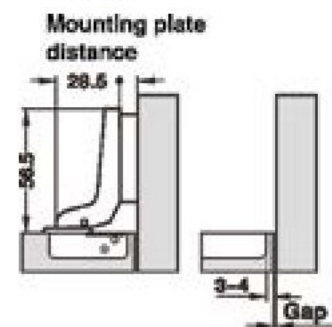

3 Inset mounting

Note:

- Not suitable for undersink application
- BOM article consist of 2 Hinges + 2 Mounting Plates
- We dont provide screws with these Articles, (Please use nickel plated screws to avoid rusting)

ORDERING INFORMATION

Product Description	Mounting	Article No.
1 Metalla With 4 Hole Mounting Plate, Full Overlay Mounting	0 Crank	311.01.121
2 Metalla With 4 Hole Mounting Plate, Half Overlay Mounting	7 Crank	311.01.122
3 Metalla With 4 Hole Mounting Plate, Inset Mounting	16 Crank	311.01.123

Metalla SS304 Hinges (with Soft-Close) - Clip-On **SS 304**



Full overlay mounting with mounting plate

- Soft opening and soft closing integrated into Hinge arm
- Clip-on Mounting
- Grade 3 Hinge
- **Material:** Stainless Steel 304
- **Finish:** SS Polished
- **Cycle testing:** Passed 80,000 cycles
- Passed 96 hours salt spray test
- 3-Dimensional adjustment

Technical Information:

- **Opening angle:** 98°
- **Thickness of hinge arm:** 11.3 mm
- **Diameter of hinge cup:** 35 mm
- **Door thickness:** 14-30 mm
- **Drilling pattern:** 48x6 mm
- **Drilling depth:** Hinge cup 12.0mm
- **Adjustment facility:** Side adjustment ±3.0mm, height adjustment ±2 mm (via mounting plate), depth adjustment: -0.5,+6.5mm

Product Application:

- Kitchen under sink cabinets
- Coastal areas

Full overlay mounting

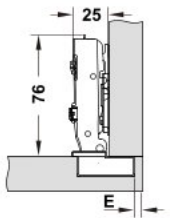

Door Overlay mm									
10	11	12	13	14	15	16	17	18	
				3	4	5	6	7	0
		3	4	5	6	7			2
Distance to cup E mm					Mounting plate distance mm				

Soft closing mechanism	Drilling pattern		
		45/9.5	48/6
With	334.00.000	334.01.000	334.02.000
Without	334.00.010	334.01.010	334.02.010

Packing: 200 pieces

Half overlay mounting

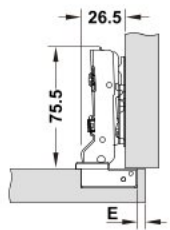

Door Overlay mm									
1	2	3	4	5	6	7	8	9	
				3	4	5	6	7	0
		3	4	5	6	7			2
Distance to cup E mm					Mounting plate distance mm				

Soft closing mechanism	Drilling pattern		
		45/9.5	48/6
With	334.10.000	334.11.000	334.12.000
Without	334.10.010	334.11.010	334.12.010

Packing: 200 pieces

Inset mounting

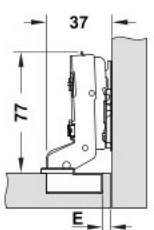

Door Overlay mm									
-5	-4	-3	-2	-1	0	1	2	3	
				3	4	5	6	7	0
		3	4	5	6	7			2
Distance to cup E mm					Mounting plate distance mm				

Soft closing mechanism	Drilling pattern		
		45/9.5	48/6
With	334.20.000	334.21.000	334.22.000
Without	334.20.010	334.21.010	334.22.010

Packing: 200 pieces

Note: Article consists of 2 hinges + 2 mounting plates + 12 screws

ORDERING INFORMATION

Product Description	Article No.
1 Stainless Steel Soft Close Hinge, 48/6 mm, Full Overlay, 104° Opening, SS Polished	311.01.652
2 Stainless Steel Soft Close Hinge, 48/6 mm, Half Overlay, 104° Opening, SS Polished	311.01.653
3 Stainless Steel Soft Close Hinge, 48/6 mm, Inset overlay 104° Opening, SS Polished	311.01.654

Metalla Thick Door Hinges (with Soft-Close) - Clip-On

- **Material:** Mild steel
- **Finish:** Nickel plated
- **Anti corrosion testing:** Cleared 48 hours of salt testing
- **Material certification:** TUV certified
- **Cycle testing:** Passed 20,000 cycle test

Technical Information:

- **Opening angle:** 95°
- **Hinge boss depth:** 13.5 mm
 - **For full overlay:** 18-30 mm
 - **For half overlay:** 18-30 mm
 - **For inset:** 18-25 mm
- **Diameter of hinge cup:** 40 mm
- **Door thickness:** 18-30 mm
- **Drilling pattern:** 52/5.5 mm

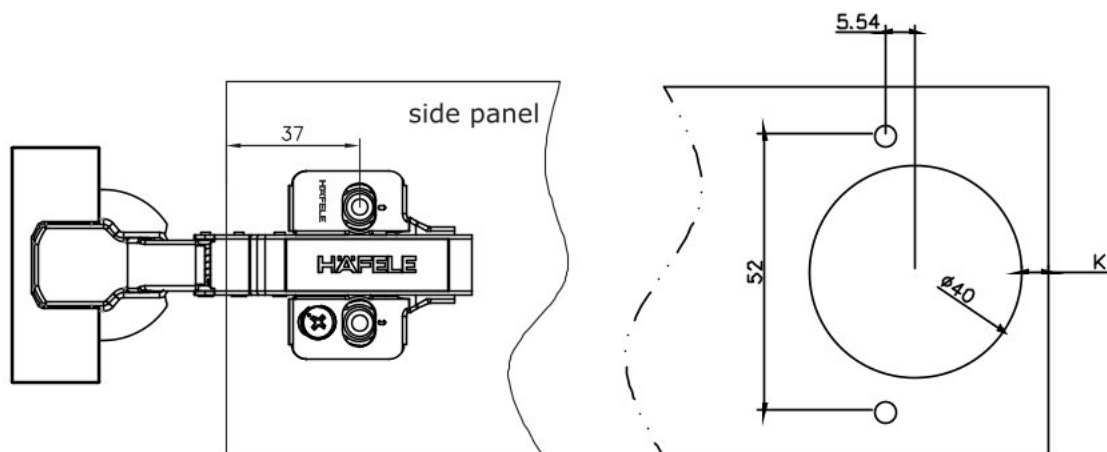
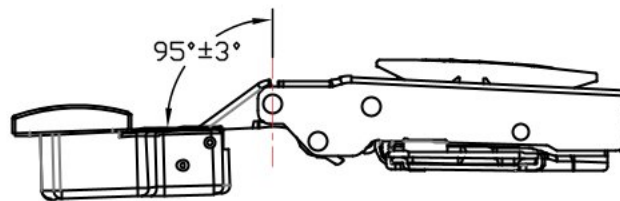

Note:

- Not suitable for undersink application
- 1 set consist of 2 hinges+2mounting plates +8 fixing screws +2 hinge cup caps +2 hinge arm cap

ORDERING INFORMATION

Product Description	Article No.
1 Thick door Metalla Soft Close Hinge, Full Overlay, 30mm Door Thickness	315.07.072
2 Thick door Metalla Soft Close Hinge, Half Overlay, 30mm Door Thickness	315.07.073
3 Thick door Metalla Soft Close Hinge, Inset, 25 mm Door Thickness	315.07.074

Eco Metalla Hinge



- Slide-on Mounting
- **Material:** Mild steel
- **Finish:** Nickel plated
- **Cycle testing:** Passed 20,000 cycles
- Passed 24 hours salt spray test
- 3-Dimensional adjustment

Technical Information:

- **Opening angle:** 110°
- **Thickness of hinge arm:** 11.3 mm
- **Diameter of hinge cup:** 35 mm
- **Door thickness:** 14-22 mm
- **Finish:** SS Polished
- 4 hole mounting plate

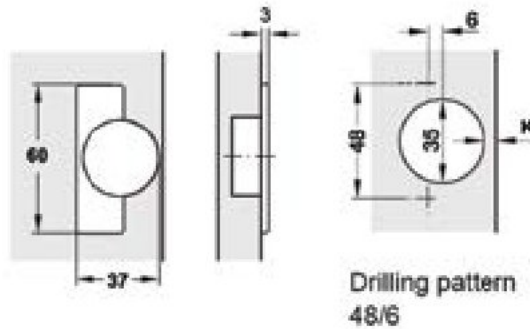

Note:

- Not suitable for undersink application
- Article consists of 2 Hinges+2 Mounting Plates+ 12 fixing screws

ORDERING INFORMATION

Overlay	Article No.
1 Full Overlay With 4 Hole Mounting Plate, Steel Nickel Plated	483.01.745
2 Half Overlay With 4 Hole Mounting Plate, Steel Nickel Plated	483.01.746
3 Inset With 4 Hole Mounting Plate, Steel Nickel Plated	483.01.747

Metalla Pie Cut Hinges - Clip-On

- **Material:** Cup - Steel,
Hinge arm & Mounting plate - Zinc alloy
- **Finish:** Nickel plated

Technical Information:

- **Drilling pattern:** 48/6 mm
- **Hinge cup dia:** 35 mm
- **Drilling depth** 11 mm
for cup:
- **Door thickness:** 14-22 mm
- **Opening angle:** 135°

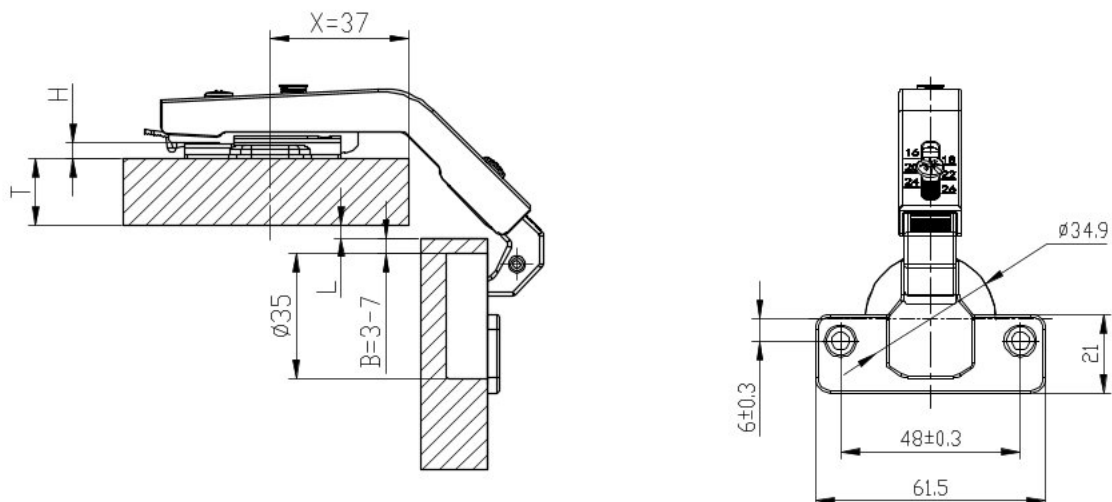

	Door thickness < 18mm	22mm>Door thickness>18mm
H	2	0
X	37	37

X-Mounting plate drilling holes-position.

Note: Article consists of 2 hinges+2 mounting plate+8 screws

ORDERING INFORMATION

Product Description	Article No.
1 Pie Cut Corner Hinge 135° 48/6 mm	311.66.542

Metalla Wide Angle Hinges (with Soft-Close) - Clip-On



Wide Angle Metalla Hinge with integrated Soft Close

- **Material:** Mild steel
- **Finish:** Nickel plated
- 3-Dimensional adjustment
- Full overlay mounting

Technical details:

- **Opening angle:** 165°
- **Thickness of hinge arm:** 11.5 mm
- **Diameter of hinge cup:** 35 mm

Applications:

- Pantry pullouts
- Larder units
- Tall units

Installation requisites:

- **Door thickness:** 14-22 mm
- **Drilling pattern:** 48 x 6 mm
- **Certification details:**
- Salt spray test: Tested for 48 hrs
- Cycle testing: 40,000 cycles
- Material certified by TÜV Germany



1 Full overlay mounting with mounting plate

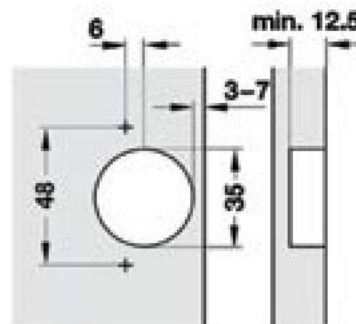
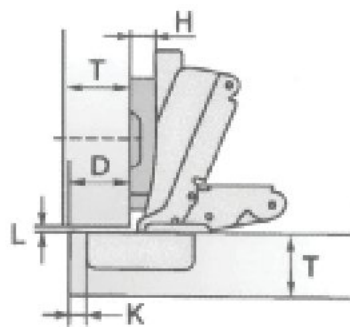

K	3	4	5	6	7
D	17	18	19	20	21

- H - Mounting plate thickness (H=0)
- K - Distance to the cup from the edge of the door
- D - Door Overlay
- T - Door Thickness / Side Panel
- L - Gap

Note: Article consists of 2 hinges + 2 mounting plates + 8 screws

ORDERING INFORMATION

Product Description	Mounting	Article No.
1 Wide Angle Metalla Soft Close Hinge 165°	0 Crank	315.07.012

Kimana

Kimana is the new hinge to open and close drop-down doors. Provided with a unique and exclusive movement, it allows to open doors even when the bottom lies upon another panel.

- The small dimensions (Ø 26 mm boring for both the door and the bottom) and minimalistic and elegant design contribute to make Kimana not only a functional hinge, but also a product unique in its genre.
- It helps in attaining zero protrusion surface in drop down doors.
- Kimana can be easily adjusted through the screws which are hidden underneath the cover.
- The fixing screws are perpendicular, thus making Kimana perfectly placed in position and suitable for aluminium profiles.
- Various door and bottom thickness-combinations can be solutioned as Kimana allows the ideal movement and alignment of the door.
- Zinc alloy and steel.

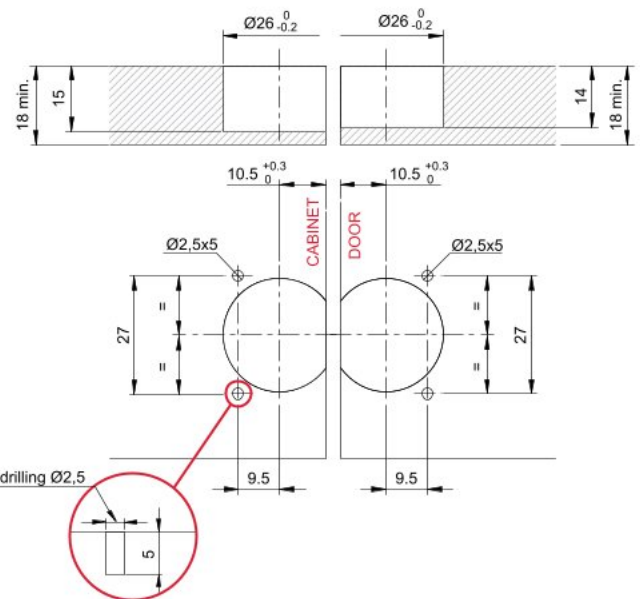
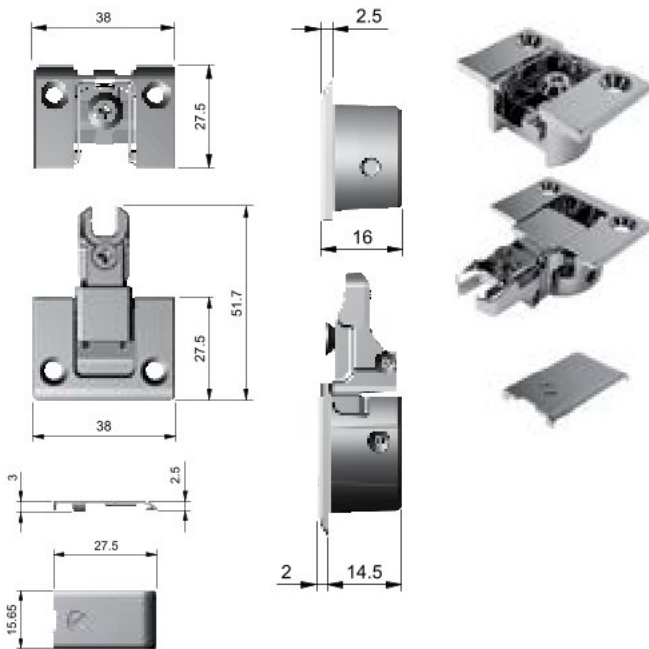

NUMBER OF HINGES

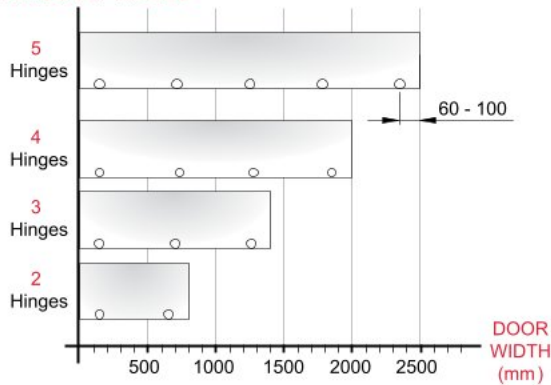

ORDERING INFORMATION

Product Description		Article No.
1	Kimana Hinge Kit, Black Nickel	342.73.310
2	Kimana Hinge Kit, Nickel Plated	342.73.610

Each set includes wood screws and instruction sheet.

CORNER UNITS



QANTO

Optimize your space with maximum storage 

Requirements regarding kitchens have changed enormously in recent years. Exacting design standards are now every bit as important as outstanding functionality. It is precisely due to these customers' requirements that Häfele's new plug and play corner solution – Qanto hits the mark.

This new pre-assembled corner solution comes with two versatile trays that can be extracted and retracted vertically by a linear drive, at a press of a button. Just one press on the integrated switch is all it takes for the Qanto trays to rise up. Reaching stored items in the kitchen has never been as easy.

The top tray that seals the gap when fully retracted can be fitted with a wooden board or can accommodate a "little urban garden" for fresh herbs. The tray below it offers further organisational space and storage for electrical appliances, perhaps or for wine and spices. The trays are crafted from high quality, easy to clean ABS with a polished crystal glass finish and are completely illuminated by LED light fixtures integrated beneath the top tray.



Product Specifications

- **Number of trays mounted:** Two
- Integrated LED Light
- **Colour temperature of LED light:** Warm white
- **Operation:** Linear drive lifting mechanism
- **Max. load bearing capacity for upper tray:** 10kg
- **Max. load bearing capacity for bottom tray:** 15kg
- **Stroke distance:** 500mm
- **Time taken for Qanto corner solution to completely move out:** 15 secs

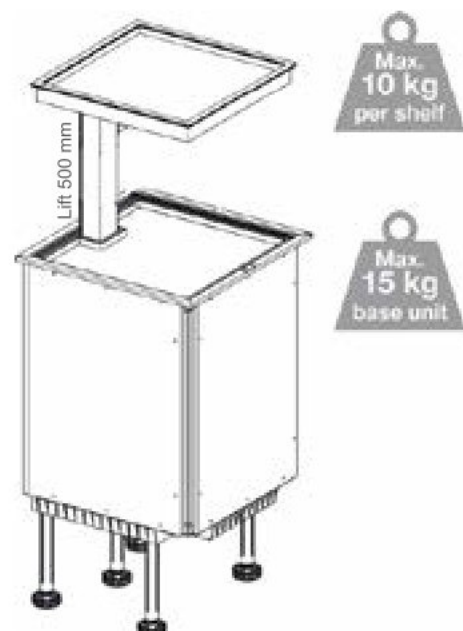

ORDERING INFORMATION

Product Description	Article No.
1 Qanto Corner Solution	542.72.300

VS COR Fold



Planero Lava Grey

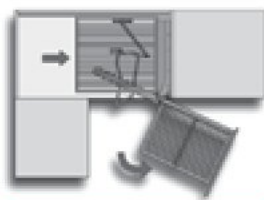

1 VS COR Fold Right

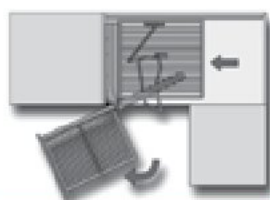

2 VS COR Fold Left

VS COR Fold, is the most optimized version among the classic corner cabinets. Due to its user-friendly movement, the Wari corner is easily accessible when opened. Thanks to its fronts with integrated 3D adjustment and central height alignment, the VS COR Fold can be fitted perfectly. By opening the cabinet, the front baskets swing sideward automatically enabling free access to the rear baskets. The newly integrated damping guarantees a quiet and smooth closing of the pull-outs.

VS COR Fold, technical details:

- Variants for corner cabinets with min. door widths of 450 mm
- Easy assembly of fronts with central height alignment
- Height adjustable storage elements
- **Available basket variants:** Premea grey, Artline chrome, Premea chrome and Planero lava grey
- Intergrated soft closing mechanism
- Adjustable opening angle
- **Installation depth:** Min. 485 mm
- **Installation height:** Min. 530 mm
- **System payload capacity:** 35 kg
- **Payload capacity:** 8 kg front basket (max.)
9.5 kg rear basket (max.)



Premea basket



ARTLINE basket



Planero basket

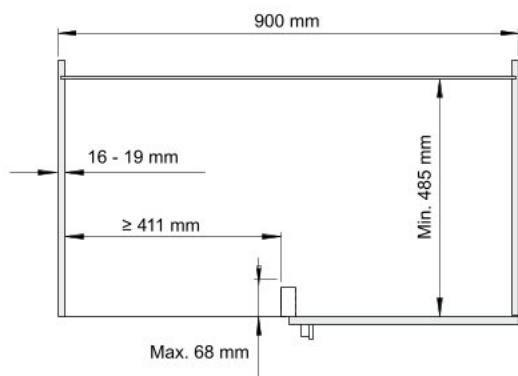

Cabinet dimension

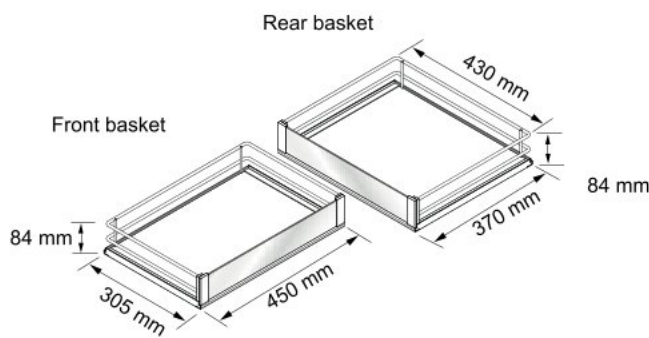

Product dimension

Note: Right & Left to be ordered depending on Corner Construction

ORDERING INFORMATION

Product Description	Artline Chrome	Premea Grey	Planero Lava Grey
1 VS Cor Fold for 900 mm cabinet width - 450 mm door width Right	548.18.231	548.18.980	548.13.386
2 VS Cor Fold for 900 mm cabinet width - 450 mm door width Left	548.18.230	548.18.981	548.13.387

VS CORNERSTONE® Swing

THE CORNER IN THE CENTRE.

The CORNERSTONE® Swing carousel moves the entire content in front of the unit, thereby unlocking completely new design perspectives. The shelves swivel out to a comfortable distance away from the cabinet; everything is within easy reach. Each shelf can be attached at the required height, and the shelves disappear back inside the unit when the door is closed.

Details

- L-movement of the shelves allows free access to neighbouring cabinets
- Unhanded
- Easy assembly - only support tube needs to be mounted
- Optional door attachment, modular design
- Soft-close damping
- **Cabinet width:** 900 mm
- **Door width:** 450 mm
- **Storage version:** Rail

Benefits

1. Lower tray automatically slides out when cupboard is opened
2. Optimal access with everything within reach
3. Lower trays automatically slide back in when cupboard is closed
4. Customisable height adjustment
5. Up to 18 kg per tray
6. Maximised storage space & optimal access



VS CORNERSTONE® Swing I Rail

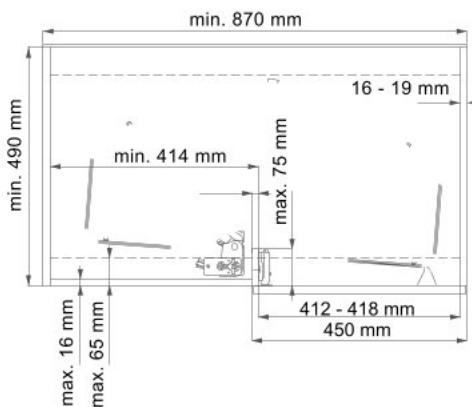
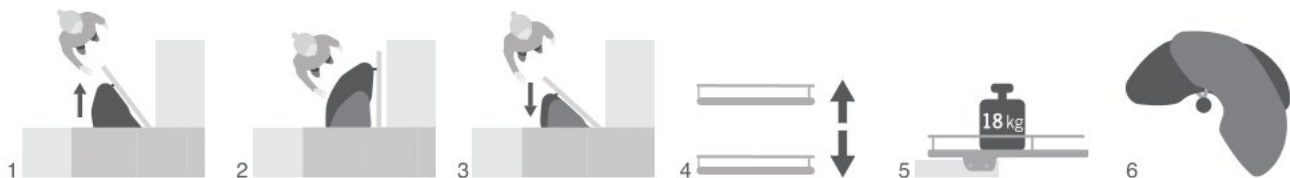

Cabinet dimension

ORDERING INFORMATION

Product Description	Premea Chrome	Silver Grey
1 CORNERSTONE Swing Universal for 900 mm cabinet	542.02.771	-
2 CORNERSTONE Swing Universal for 900 mm cabinet	-	542.13.971

VS Cornerstone Maxx



1 VS Cornerstone Maxx



When you use the corner cabinet in the kitchen, you need a solution that meets you with the full contents - without obstructing the adjacent cabinets. CORNERSTONE MAXX fulfills this need. Straight-extending kinematics with energy storage support, floating design with wide stable shelf surface and simple installation. Your kitchen is upgraded in every respect as a result.

Details

- Simple height adjustment, even when installed
- The bases can be moved in and out independently and do not obstruct
- Floating design due to hidden fastening
- Large-area shelves
- **Cabinet widths:** 900 and 1,200 mm
- **Door widths:** 450 and 600 mm
- **Installation depth:** min. 490 mm
- **Load capacity:** max. 25 kg per shelf
- **EasyFit:** Tool-free assembly of shelf elements on the support arms
- **PAM:** Power assisted movement in pull-out direction resulting in soft open and close
- **Storage version:** Planero lava grey

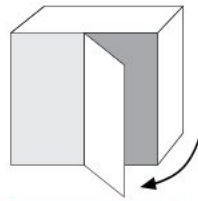

1 right-handed

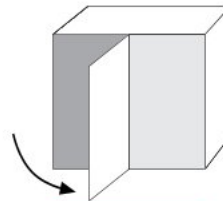

2 left-handed

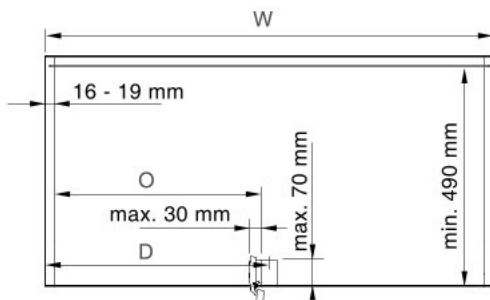

D	W	O
450 mm	600 mm	min. 411 mm
900 mm	1000 mm	min. 561 mm

Product Description		Planero Lava Grey
1	Cornerstone Maxx for 900 mm cabinet width Right version, 450 mm door	542.02.492
2	Cornerstone Maxx for 900 mm cabinet width Left version, 450 mm door	542.02.493
3	Cornerstone Maxx for 1200 mm cabinet width Right version, 600 mm door	542.02.496
4	Cornerstone Maxx for 1200 mm cabinet width Left version, 600 mm door	542.02.497

VS COR Flex

Maximum access in any corner cabinet makes the best use of storage space and keeps things organized and accessible.

VS COR Flex maximizes space in corner cabinets while allowing full accessibility to the entire unit. Right and left handed versions are identical. This non-handed corner unit is easily installed to the bottom of the cabinet. With the VS COR Flex all the space in corner cabinets is turned into functional, reliable and stylish storage space. The unit can be fully retracted from the cabinet and all the shelves can be easily accessed.

Details

- Individual height adjustment for baskets
- Integral soft-closing and self-closing on both pull-outs
- **Cabinet width:** min. 900 mm
- **Door width:** min. 450 mm
- **Installation depth:** min. 500 mm
- **Installation height:** min. 530 mm
- **Installation template:** No measuring necessary when installing into cabinet
- **Max. load:** 8 kg per basket
- **Max. load-bearing:** 32 kg
- **Storage versions:** Premea chrome, Premea grey & Planero lava grey



VS COR Flex, Planero

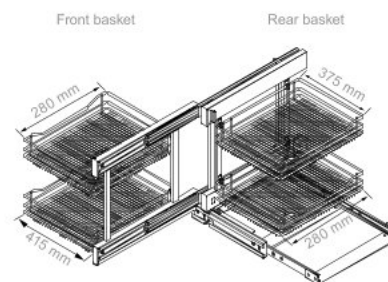
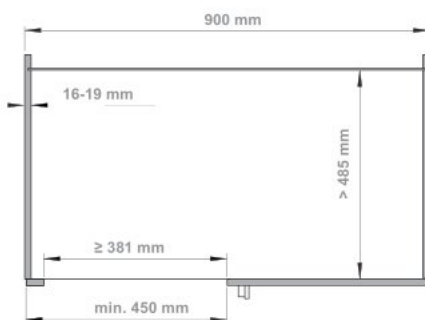

Flex corner frame with basket set

ORDERING INFORMATION

Product Description	Premea Grey	Planero Lava Grey
VS Cor Flex for 900 mm cabinet width	548.29.283	548.29.343

Eco Pro-Arc Powerslide



The Functional Tray System

Timeless design, highest processing quality

The interior of a kitchen should not be left to chance. Pro-Arc, a classic among carousel trays, is characterized by timeless design and proven product quality. Combined with the newly developed PowerSlide fitting, for asymmetric kitchen corner cabinets, it forms a harmonic duo. Due to its ergonomic shape and easy access to the goods stored on it, this carousel tray becomes a sought-after element in every kitchen.

Pro-Arc half trays

- One-piece moulded, seamless, and easy to clean
- Textured interior surface guarantees stability for the stored items
- Invisible underside ribbing provides for a high torsional stiffness and solidity



Features

- Easy to install and remove for cleaning and maintenance of cabinet
- Closed sides ensure no spilling of content from tray to cabinet
- Trays made up of plastic have no effect of humidity
- The trays slide straight out like a drawer, ensuring that the access to adjacent cabinets is not affected
- Loading capacity up to 20 kgs per tray
- For interior cabinet depths from 490 mm
- Available for door width minimum 450 mm

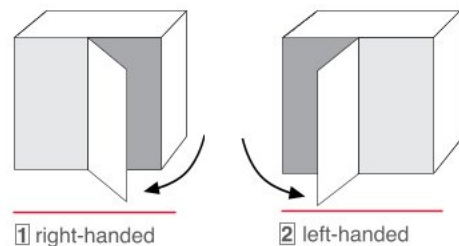
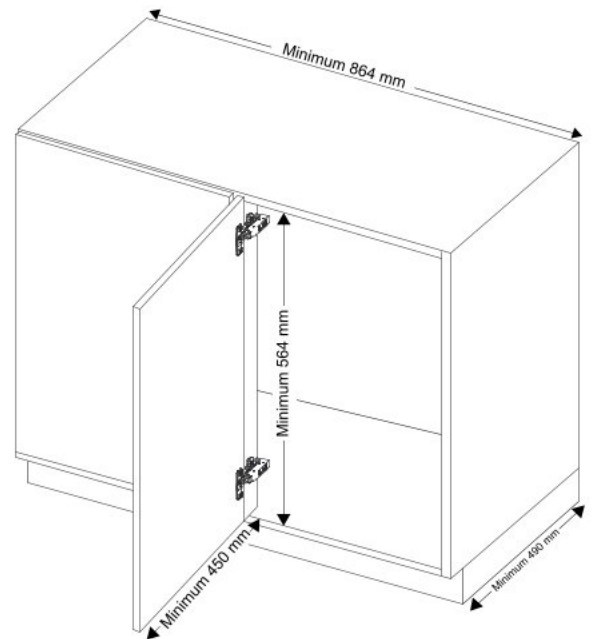

ORDERING INFORMATION

Product Description		Aluminum Grey
1	Eco Pro-Arc Powerslide for 900 mm cabinet width Right version	541.55.440
2	Eco Pro-Arc Powerslide for 900 mm cabinet width Left version	541.55.441

VS COR Wheel Pro

VS COR Wheel Pro., the corner cabinet solution with a distinctly better use of storage space. Due to its unique construction of no central column, space availability in the tray is now increased to 20% more. This corner solution is perfect to store bulky utensils too. The shelves are suspended by a diagonal rod that runs through the cabinet. The mechanics being virtually invisible just enhances the aesthetics of your kitchen.

Details

- Height-adjustable base positioning, independently of cabinet heights
- Can be installed in base cabinets, tall cabinets and top cabinets
- Can be retrofit into an installed kitchen
- **Cabinet width:** 900 x 900 mm
- **Side installation depth:** min. 490 mm
- **EasyFit:** Toolless assembly of shelf elements on the support arms
- **Load capacity:** max. 27.5 kg per shelf
- **Storage versions:** Rail and Smart



Rail Basket



Smart Basket

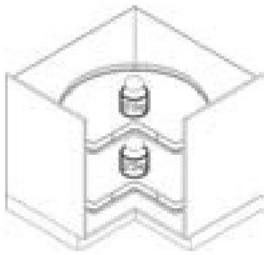

VS COR Wheel Pro 3/4

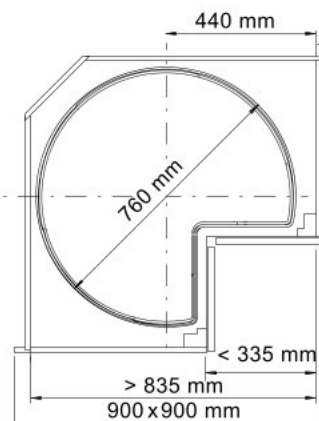

VS COR Wheel 3/4, Rail

Cabinet dimension



1 VS COR Wheel Pro Smart



2 VS COR Wheel Pro Rail

ORDERING INFORMATION

Product Description	Article No.
1 VS Cor Wheel Pro 3/4 for 900 mm Cabinet width (Smart Chrome)	542.62.742
2a VS Cor Wheel Pro 3/4 for 900 mm Cabinet width (Rail Silver)	542.62.522
2b VS Cor Wheel Pro 3/4 for 900 mm Cabinet width (Rail Chrome)	542.62.712

High End Pro-Arc Carousel Tray



L and U shaped kitchens are popular and characteristic of modern kitchen design. With its Pro-Arc tray system Häfele offers individual equipment and comfortable access in every kitchen corner – whether symmetric or asymmetric.

The tray system offers various differentiation possibilities as to colouring, edge and surface design. An optionally available non-slip foil prevents the stored items from slipping.

Features

- Optimum utilization of the storage space in every kitchen corner
- Comfortable access to the stored items thanks to extractable or revolving trays
- Timeless design
- Seamless surfaces ensure maximum hygiene
- Surfaces loadable up to 25 kg thanks to solid underside ribbing
- Slightly convex-structured surfaces avoid wear and tear
- For all established cabinet heights
- Wide fitting range available for different corner situations



Aluminum Grey

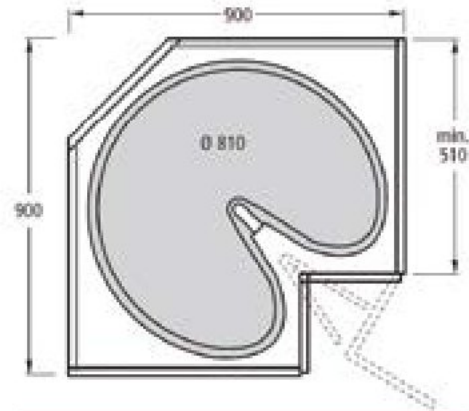

1 Carousel Tray for Cabinet Width 900 mm

ORDERING INFORMATION

Product Description	Aluminum Grey
1 High End Pro-Arc Carousel for 900 mm Cabinet width	542.85.560

TALL UNITS





VS TAL Larder

Every item in your pull-out pantry is easily accessible with full view thanks to a modern European design.

- Stabilizing of the front by front strips and 3D front adjustments.
- Height-adjustable basket assembly, using functional clip for firm grip and low - noise.
- Full pull-out with damping.
- The specially developed silver grey finish is anti corrosive and prevents the metal parts from rusting under harsh conditions.
- **System payload capacity:** 80 kg
- **Installation depth:** 500 mm
- **Installation height:** 1900-2140 mm

New improvements -

- **Available basket variants:** Premea grey, Premea chrome, Artline chrome & Planero lava grey
- Improved operation due to new roller bearing, automatic closing and enhanced profile geometry
- **EasyFit:** Click system for assembling the frame on the lower and upper rails. Synchronic end caps up and down guarantee stability.



Premea Basket



Artline Basket



Planero Basket

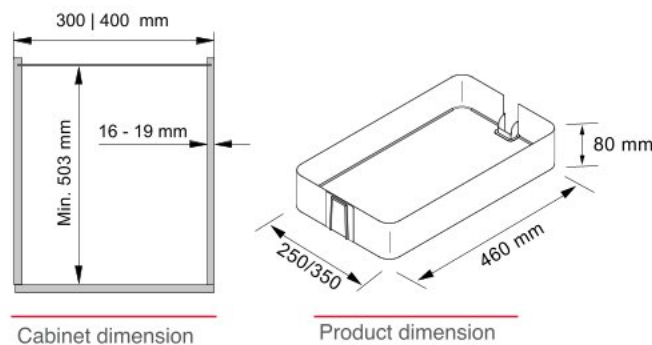

ORDERING INFORMATION

Product Description	Premea Grey	Artline Chrome	Planero Lava Grey
1a VS Tal Larder Frame 6 (1,900 - 2,140 mm) 300 mm	547.49.915	547.49.715	547.49.415
1b VS Tal Larder Frame 6 (1,900 - 2,140 mm) 400 mm	547.49.935	547.49.735	547.49.435

Note: Set includes baskets.

Frame 6: 5 baskets



VS TAL Larder Spin

VS TAL Larder Spin^(90° swivel on either sides)

The term 'comfort' needs to be redefined for kitchens with the new VS Tal Larder Spin

- VS Tal Larder Spin provides optimum functionality and optimum accessibility along with European style.
- VS Tal Larder Spin enables the user to swivel the entire unit to the right or to the left for optimal and better ergonomic access.
- VS Tal Larder Spin integrated with soft closing mechanism ensures gentle and silent closing.
- Installation is easy and effortless
- Total load capacity of 120 kg
- **Installation depth:** 500 mm

New improvements:

- **Available basket variants:** Premea grey, Premea chrome, Artline chrome & Planero lava grey
- Stabilizing front strips
- 3D front adjustment
- Functional clip for height adjustment of the basket assembly; firm grip and low-noise level.



Premea Basket



Artline Basket



Planero Basket

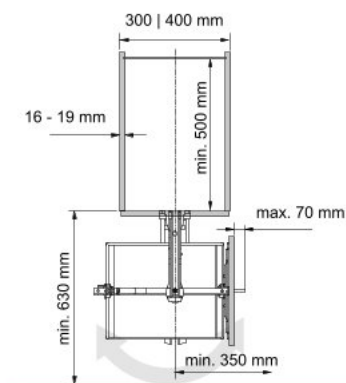

Cabinet dimension

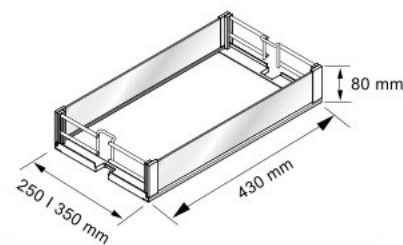

Product dimension

ORDERING INFORMATION

Product Description		Premea Grey	Artline Chrome	Planero Lava Grey
1	VS Tal Larder Spin Frame 6 (1,990 - 2,230 mm) 300 mm	547.46.905	547.46.305	547.46.405
2	VS Tal Larder Spin Frame 6 (1,990 - 2,230 mm) 400 mm	547.46.925	547.46.325	547.46.425

Note: Set includes baskets.

Frame 6: 5 baskets



VS TAL Gate Pro

VS Tal Gate Pro is an ergonomically designed basket pull out for the kitchen. The baskets swing out when the cabinet is being opened; this enables easy access to its content and optimum use of storage space.

Details

- **Cabinet widths:** 450 and 600 mm
- **Installation depth:** min. 480 mm
- **EasyFit:** Toolless frame assembly on the lower runner
- **EasyFit:** Toolless connection between the driver and support frame
- Individually height-adjustable baskets
- **System payload capacity:** front basket max. 20 kg (5 kg per basket), pull-out max. 80 kg (20 kg per basket)
- **Storage versions:** Premea, Artline and Planero



Premea Basket



Artline Basket



Planero Basket

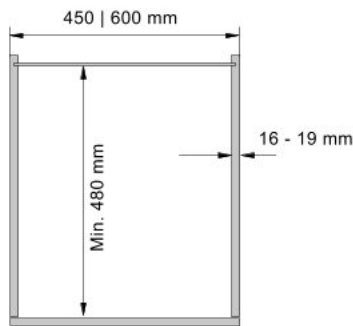

Cabinet dimension

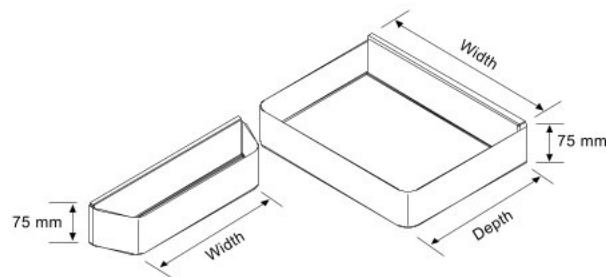

Product dimension

Front basket dimension

Cabinet width	Width	Depth
450mm	365 mm	110 mm
600 mm	465 mm	110 mm

Rear basket dimension

Cabinet width	Width
450mm	350 mm
600 mm	500 mm

ORDERING INFORMATION

Product Description		Premea Grey	Artline Chrome	Planero Lava Grey
1	VS Tal Gate Pro Frame 6 (1,900 - 2,150 mm) 450 mm	547.27.505	547.27.405	547.27.005
2	VS Tal Gate Pro Frame 6 (1,900 - 2,150 mm) 600 mm	547.27.525	547.27.425	547.27.025

Note: Set includes baskets.

Frame 3: 4 baskets

Frame 6: 5 baskets



VS TAL Gate

Slightly different from the VS Tal Gate Pro – but boasting of the same advantages – the VS Tal Gate storage unit sets new standards in comfort and design. Its efficient opening mechanism allows the storage baskets to automatically slide out once the cabinet door is opened; providing for maximum storage space along with easy access.

- Comes with an integrated damping system that ensures soft and silent closing
- Comes with an advanced opening mechanism that automatically slides out the baskets on opening the cabinet, making way for optimum reach.
- 3-Dimensional front adjustment facility allows for perfect symmetry and the convenience of adding or removing the baskets from the cabinet frame as per your storage needs.

Details:

- **Carcase widths:** 450 & 600 mm
- **Min. installation depth:** 480 mm
- **EasyFit:** Free installation of frame onto the lower runners
- **EasyFit:** Tool free attachment of carriers to mounting frame
- Individual height adjustment for baskets
- **System payload capacity:** Max. 75 Kg
- Available in Premea grey, Premea chrome, Artline chrome & Planero lava grey



Premea Basket



Artline Basket



Planero Basket

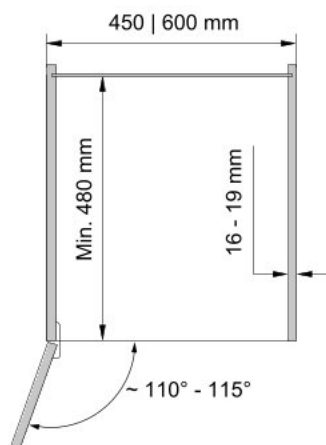

Cabinet dimension

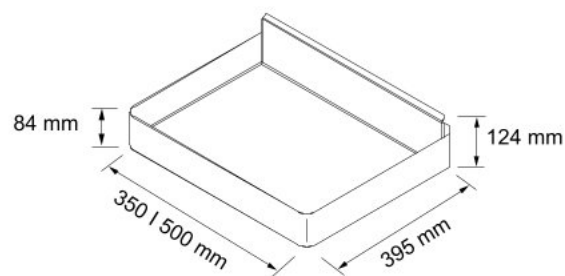

Product dimension

ORDERING INFORMATION

Product Description		Premea Grey	Artline Chrome	Planero Lava Grey
1	VS Tal Gate Frame 3 (1,200 - 1,450 mm) 450 mm	549.58.521	549.58.421	
2	VS Tal Gate Frame 3 (1,200 - 1,450 mm) 600 mm	549.58.541	549.58.441	
3	VS Tal Gate Frame 6 (1,900 - 2,150 mm) 450 mm	549.58.524	549.58.424	549.58.224
4	VS Tal Gate Frame 6 (1,900 - 2,150 mm) 600 mm	549.58.544	549.58.444	549.58.244

Note: Set includes baskets.

Frame 3: 4 baskets

Frame 6: 5 baskets

VS TAL Gate N



1 VS TAL Gate N, Premea

The practical storage cabinet pull-out with a flowing opening movement uses narrow cabinets for optimal storage space. With a single grip it provides an insight into the entire contents of the cabinet. The elegant tall cabinet solution with a door opening of 160° offers individual, ideal adjustment to the cabinet contents by height adjustable shelves. Storage containers and packaging find a suitable place here. They are easily visible and thus ready to hand. With only one pull the total inventories are placed in front of the cabinet - the optimal storage solution.

Details

- **Cabinet width:** 400 mm
- **Min. installation depth:** 480 mm
- **EasyFit:** Tool-free installation of frame onto the lower runners
- **EasyFit:** Tool-free attachment of carriers to mounting frame
- Individual height adjustment for baskets
- **Max. load-bearing:** 75 kg
- **Storage versions:** Premea chrome & Planero lava grey



Premea Basket



Planero Basket

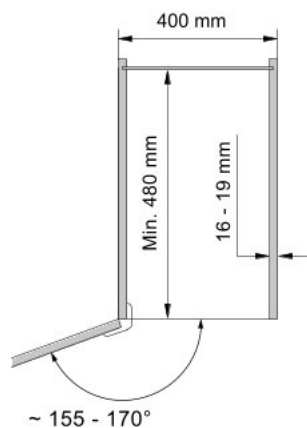

Cabinet dimension

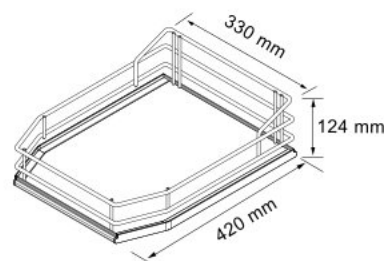

Product dimension

ORDERING INFORMATION

Product Description	Planero Lava Grey
1 VS Tal Gate N Frame 6 (1,900 - 2,150 mm) 400 mm	549.58.214

VS TAL Wiro Bottle 15

The new bottle pull-out storage unit is a good storage place for homemade fruit juices and wines. Already familiar from the base cabinet, it is now available for high cabinets from a height of 185 centimetres and in this version presents itself as, among other things, a convenient end cabinet. Fitted with the Classic basket end cabinet, it is a real eye-catcher and offers adequate storage space for 16 bottles and further accessories.

Details

- **Cabinet width:** 150 mm
- **Min. installation depth:** 500 mm
- **Min. installation height:** 1,780 mm
- **Storage versions:** Grey, Chrome & Lava grey
- **Load capacity max:** 25 kgs
- 3-D front adjustment allows simple, convenient front adjustment
- Integral soft-closing and self-closing

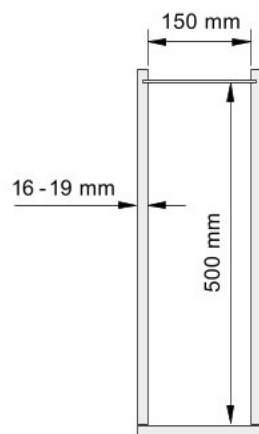

Cabinet dimension

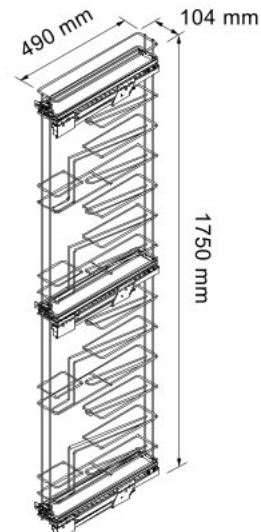

Product dimension

ORDERING INFORMATION

Product Description	Grey	Planero Lava Grey
1 VS Wiro Bottle Rack (16 Bottles)	549.85.931	549.85.503

VS Wiro Broom Pull Out



A practical fitting for a broom cabinet.

Details

- **Cabinet width:** 150 mm
- **Min. installation depth:** 500 mm
- **Min. installation height:** 1,780 mm
- Includes five shelves and four 1.2 litre plastic trays
- With front attachment
- Under mount slide with soft-close and damping
- 3-D front adjustment allows simple, convenient front adjustment
- **Max. load-bearing:** 25 kg
- **Storage versions:** Grey (Left hand access)
Lava grey (Right hand access)

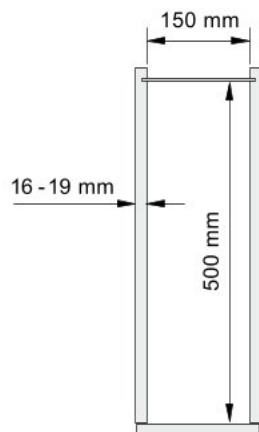

Cabinet dimension

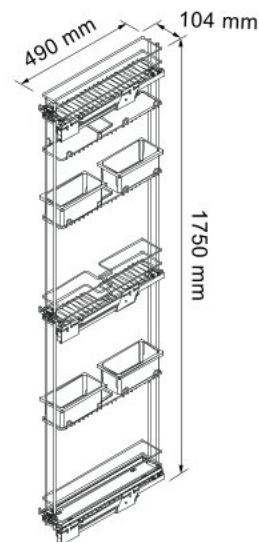

Product dimension

ORDERING INFORMATION

Product Description	Grey	Planero Lava Grey
1 VS Wiro Broom Pull Out	549.94.900	549.85.343

Chef's Pantry Pull Out

Chef Pantry Pull-Out System

The kitchen is probably the most used room in the house. It is where the day starts and ends and is generally a hive of activity when the family is at home. It is therefore very important that this room is well organized and the use of space is carefully planned. Häfele's Chef Pantry pull out unit is one product that can be used to organize your space to the maximum. It has adjustable height facility and soft close mechanism which ensure a noiseless closing experience.

Features:

- **Material:** Steel
- **Finish:** Basket bright chrome plated
- **Frames** are powder coated for longer life
- **Version:** Soft Closing
- **For cabinet width:** 900mm **Thickness:** 16 - 19mm
- **Min. internal cabinet depth:** 500mm

Chrome basket, Inner

Basket for inner frame

- **Width x Depth x Height:** 356 x 115 x 80 mm
- Chrome-plated steel wire

Chrome basket, Swivel frame

Basket for swivel frame

- **Width x Depth x Height:** 356 x 115 x 80 mm
- Chrome-plated steel wire

Chrome basket, Door

Basket for door mounted hanging rails

- **Width x Depth x Height:** 356 x 102 x 80mm
- Chrome-plated steel wire

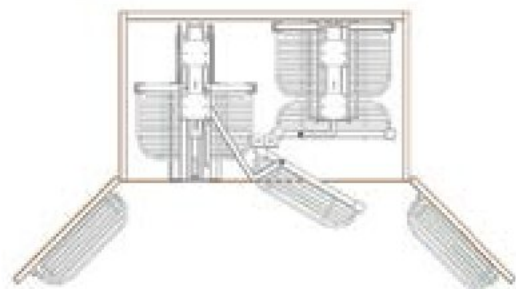

When the swivel frame is opened inner extension frame is automatically moves forward.

Load capacity:

546.97.206 - 156 kgs
546.97.202 - 104 kgs

- Rear Basket - 8 kg.
- Swing Basket - 3 kg
- Door Basket - 2 kg

ORDERING INFORMATION

Product Description	Rear Basket	Swing Basket	Door Basket	Total Baskets	Chrome
1 Swing Out Chef's Pantry Unit for 900 mm cabinet width (1900mm - 2200 mm)	12	12	12	36	546.97.206
2 Swing Out Chef's Pantry Unit for 900 mm cabinet width (1200mm - 1500 mm)	8	8	8	24	546.97.202

ROLLER SHUTTERS



Metallic Line & Easy Line Roller Shutter

Häfele brings to you the latest in modern kitchen designing - **Roller Shutter System** that's easy to install and a very convenient solution to store your kitchen appliances. These shutters are aesthetically more appealing because the gaps between the slats become smaller in closed state, making your kitchen look more attractive.

They provide optimum functionality with a high quality mechanism that ensures a smooth motion. This stylish system requires a flat bottom profile to be fitted in and is ready to be installed in the finished furniture cabinet, These are available in PVC shutter options.

Features:

- Easy to install cassette
- Light weight supporting material covered with an aluminum foil on ABS plastic
- Metallic line available in aluminum silver finish
- Easy Line available in silver finish
- Available in width 600 & 900 mm with height 1350 mm



The set includes following parts

- 1 1 x Cassette
- 2 2 x Pelmet adapter
- 3 1 x Pelmet
- 4 2 x Vertical tracks (End cap pre-installed)
- 5 14 x Ø3 x 14 mm
6 x Ø4 x 20 mm
2 x Ø4 x 25 mm
- 6 1 x Installation Guide



Cabinet dimensions

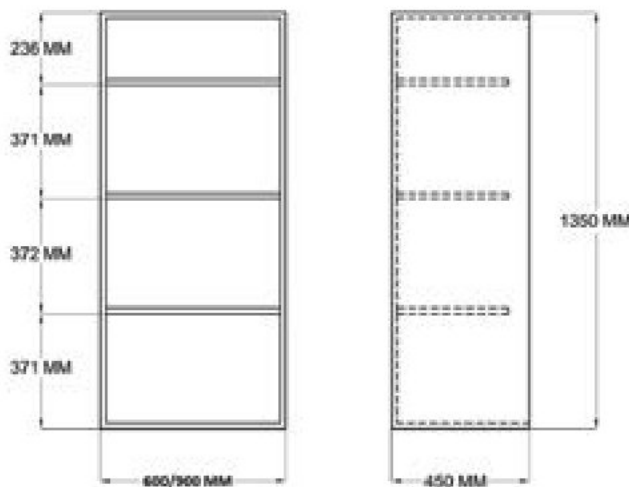

Measurement

For 600/900 mm cabinet the maximum height will be 1350 mm. The height required for cassette is minimum 236 mm.

ORDERING INFORMATION

Product Description	Finish	Size (mm)	Article No.
1 Metallic Line Roller Shutter	Metallic Aluminium	(W) 600 x (H) 1350 (W) 900 x (H) 1350	442.84.942 442.84.943
2 Easy Line Roller Shutter	Silver	(W) 600 x (H) 1350 (W) 900 x (H) 1350	442.84.940 442.84.941

Vetro Line - Glass Roller Shutter



Features:

- **Space Saving:** Our glass roller shutters save up to 30% more space as compared to regular swing doors - the shutter can be left open at any desired height for the convenience of 100% access.
- **Operation:** The excellent gliding properties of our glass roller shutters offer smooth and quiet opening and closure of the cabinet.
- **Material:** Our roller shutters are made of high grade tempered glass that is extremely easy to handle and install.
- **Tested to last:** The glass roller shutters have been tested to withstand extreme heat, steam and water conditions in the kitchen.

The set includes following parts

- 1 x Cassette
- 2 x Pelmet adapter
- 1 x Pelmet
- 2 x Vertical tracks (End cap pre-installed)
- 14 x Ø3 x 14 mm
6 x Ø4 x 20 mm
2 x Ø4 x 25 mm
- 1 x Installation Guide

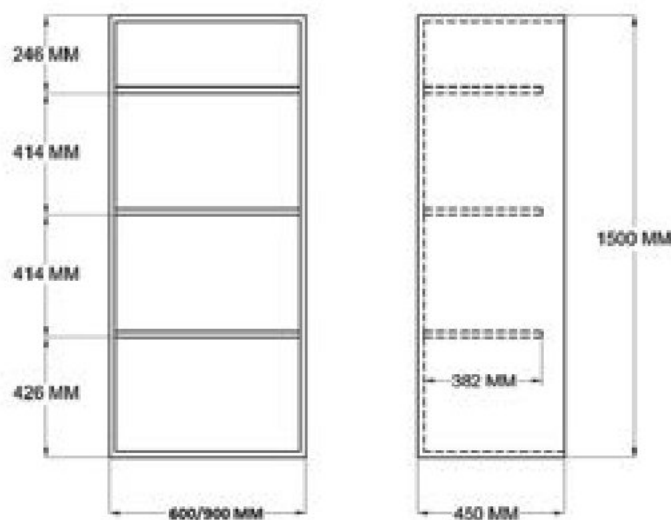

Measurement

For 600/900 mm cabinet the maximum height will be 1350 mm. The height required for cassette is minimum 246 mm.

ORDERING INFORMATION

Product Description		Finish	Size (mm)	Article No.
1	Vetro Line Roller Shutter	Frosted Glass	(W)600 x (H)1350	443.20.490
			(W)900 x (H)1350	443.20.491
		White	(W)600 x (H)1350	443.20.494
			(W)900 x (H)1350	443.20.495
		Black	(W)600 x (H)1350	443.20.492
			(W)900 x (H)1350	443.20.493

WASTE BINS



BO-BIN Free Standing



Häfele's BO Touch Bin is a stylish bin designed to match your kitchen's décor. Its unique soft –touch opening and closing mechanism makes it easy to operate just at the touch of your hand.

It fits perfectly against a wall space and thanks to adjustable non-skid legs which allows you to adjust the height of the bin so that you don't have to bend yourself for disposing things.

The 11+23 Litre Bo-Bins are available in 3 colour options - Matt Black, Mineral Golden Beach, and Mineral Windsor Red. Each bin includes 2 removable inner buckets and comes with 10 year guarantee.

Ease of Use:

- 'Soft-Touch' opening and closing system - opens silently with the lightest touch
- Space efficient - it fits closely to the wall or conveniently in a corner
- Sparkling mineral finish, beautiful design
- Easy waste disposal without spilling - large opening
- Perfect height - better for your back and cleaning underneath is easy
- Ideal for large chores - lid stays open
- Easy to assemble - click on legs
- Adjustable legs with non- slip base - protects the floor and keeps the bin steady
- Easy to clean - removable plastic inner bucket
- 2 removable inner buckets - ideal for waste separation at home

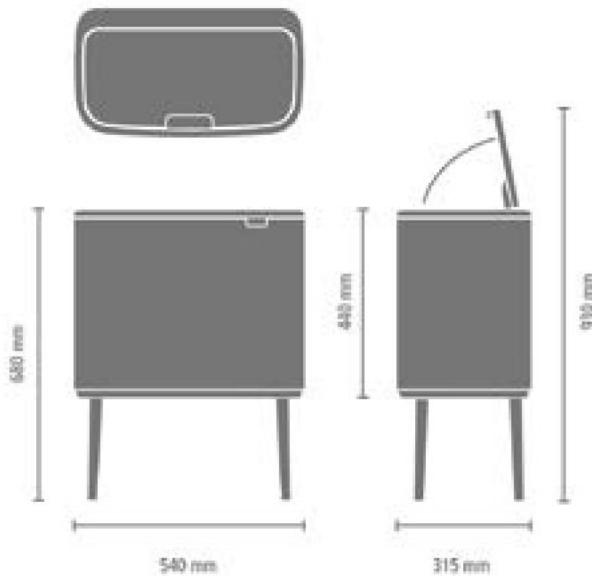

1 BO BIN - 11+23L Matt Black



2 BO BIN - 11+23L Mineral Golden Beach



3 BO BIN - 11+23L Mineral Windsor Red

ORDERING INFORMATION

Product Description		Article No.
1	BO BIN - 11 + 23L Matt Black	503.83.364
2	BO BIN - 11 + 23L Mineral Golden Beach	503.83.864
3	BO BIN - 11 + 23L Mineral Windsor Red	503.83.964

New Icon Pedal Bins

- **Type:** Freestanding waste bin
- **Available capacities:** 5 and 12 litres
- **Material:** Pre-coated Stainless Steel Grade 304
- **Colour options:** Stainless steel (Anti-fingerprint), platinum, passion red and white
- Soft closure and super-light pedal operation
- Odour-proof closure
- Easy to clean with a removable inner bucket
- Non-slip base protects the floor and keeps the bin steady
- Cradle to cradle certified
- Made up of 40% high-grade recycled materials and after use, 98% of the bin and packaging is recyclable



Stainless Steel 5L



Passion Red 12L

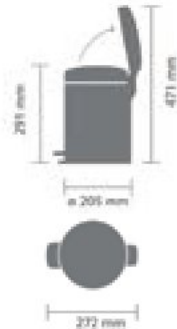

ORDERING INFORMATION

Product Description	Dimensions (W x D x H) mm	Capacity	Finish	Article No.
1	Ø 205 x 272 x 291	5 L	Stainless Steel Anti-fingerprint	503.83.171
2	Ø 251 x 338 x 411	12 L	Stainless Steel Anti-fingerprint	503.83.173
3	Ø 205 x 272 x 291	5 L	Passion Red	503.83.971
4	Ø 251 x 338 x 411	12 L	Passion Red	503.83.973
5	Ø 205 x 272 x 291	5 L	White	503.83.771
6	Ø 251 x 338 x 411	12 L	White	503.83.773
7	Ø 205 x 272 x 291	5 L	Platinum	503.83.071
8	Ø 251 x 338 x 411	12 L	Platinum	503.83.073

VS ENVI Center Waste Bin for Cabinets



- **Type:** Built-in Waste Bin
- **Available capacity:** 18 litres
- **Variants:** 1 bin (18 litres) and 2 bins (9 litres each)
- **Material:** High grade plastic
- Bin lids lift up and the bins swing out when the system is opened
- Bin lids move back snugly against the bins upon closing
- Can be combined with all standard hinges
- No additional strain on the front
- Tool-free removal and replacement after initial installation

Installation Details:

- **Min. cabinet width:** 400 mm
- **Min. installation depth:** 350 mm
- **Min. installation height:** 525 mm



1 VS Envi Center / 1 Bin capacity (18 Litre)



2 VS Envi Center / 2 Bins capacity (9 Litres each)

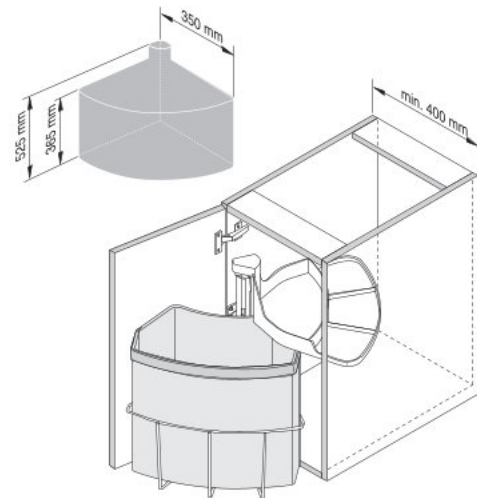

Cabinet Dimensions: Height: 525 mm, Width: 400 mm

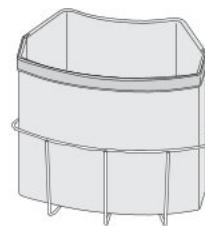

1 x 18 litres

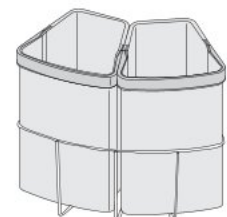

2 x 9 litres

ORDERING INFORMATION

Product Description	Capacity	Finish	Article No.
1 VS ENVI Center	1 x 18 L bin (1 set)	Grey	502.79.500
2 VS ENVI Center	2 x 9 L bin (1 set)	Grey	502.79.501

VS ENVI Space / VS ENVI Space Pro/ VS ENVI Space XX

- **Type:** Built-in Waste Bin
- **Variants:**
 - **VS ENVI Space:** 42 litres (2 × 21 litres);
Cabinet width: 450 mm
 - **VS ENVI Space Pro:** 44 litres (2 × 22 litres);
Cabinet width: 600 mm
 - **VS ENVI Space XX:** 70 litres (2 × 35 litres);
Cabinet width: 450 mm
- **Material:** High Grade Plastic
- Equipped with a guide system, the bins can be installed laterally even in small kitchen cabinets
- Soft-close pull-out guarantees quiet, effortless closing
- Can be used directly under the counter-top, ensuring easy waste disposal directly from the work surface
- Cover plate offers additional storage space



VS ENVI Space

Installation Details:

For VS ENVI Space & VS ENVI Space Pro

- **Min. installation depth:** 464 mm
- **Min. installation height:** 470 mm

For VS ENVI Space XX

- **Min. installation depth:** 480 mm
- **Min. installation height:** 580 mm



4 VS ENVI Kick Pedal

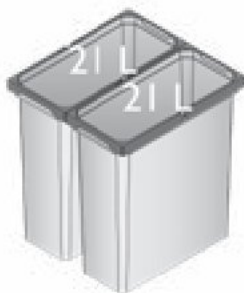

1 VS ENVI Space Pro 42 L (2x21L)
Cabinet Width: 450 mm

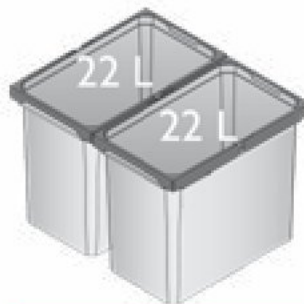

2 VS ENVI Space 44 L (2x22L)
Cabinet Width: 600 mm

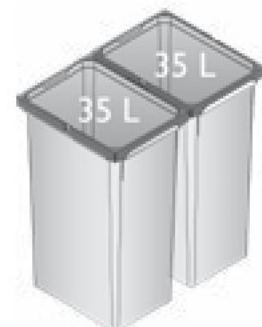

3 VS ENVI Space XX 70 L (2x35L)
Cabinet Width: 450 mm

ORDERING INFORMATION

Product Description	Dimensions (W x D x H) mm	Capacity (Litres)	Finish	Article No.
1 VS ENVI Space Pro, 2 bins	183 x 382 x 426	2 x 21	Grey	503.04.514
2 VS ENVI Space, 2 bins	230 x 382 x 326	2 x 22	Grey	503.04.508
3 VS ENVI Space XX, 2 bins	250 x 340 x 550	2 x 35	Grey	503.17.502
4 VS ENVI Kick Pedal			Grey	503.04.950

Wasteboy Waste Separator System



- **Type:** Built-in Waste Bin
- **Total available capacity:** 32 litres
- **Variant:** 2 bins (16 litres each)
- **Material:** High grade plastic
- **Colour:** Dark grey
- **Cabinet width:** 400 mm
- Compact, space-saving design for installation under the drainage pipe in the sink base cabinet
- Stable frame construction with full-extension telescopic runners ensures extremely smooth operations
- Optimized design and small gap sizes between handles and bins allows for hygienic waste separation
- Can be combined with all standard hinges
- Stable frame construction
- Cover plate offers additional storage space
- Tool-less assembly by means of latching connections

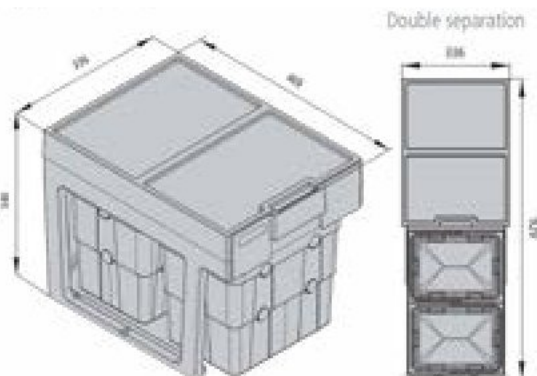

ORDERING INFORMATION

Product Description	Dimensions (W x D x H) mm	Capacity	Finish	Article No.
1 Wasteboy for 400 mm cabinet	336 x 469 x 346	2x16 L	Dark Grey	503.74.504

Drawer-Mounted Waste Bins

- **Type:** Built-in
- **Variant:**
 - **3 Bin set:** 33 litres (2 × 8 litres + 1 × 17 litres);
Cabinet width: 450 mm
 - **4 Bin set:** 50 litres (2 × 8 litres + 2 × 17 litres);
Cabinet width: 600 mm
 - **6 Bin set:** 75 litres (3 × 8 litres + 3 × 17 litres);
Cabinet width: 900 mm
- **Material:** High grade plastic
- **Colour:** Aluminium grey
- **Cabinet width:** 450 mm – 900 mm
- Compact, space-saving design for installation in the under sink drawers
- Intelligently and systematically combined as a set, the bins offer individual configurations for varied applications
- Waste bins slide out along with the drawer while opening
- Base plate avoids the bins from slipping while the drawer is in motion ensuring silent movement
- Glass-fibre reinforced carrying handles allow comfortable removal of the bins and also prevent the waste bags from slipping
- Cover plate offers additional storage space

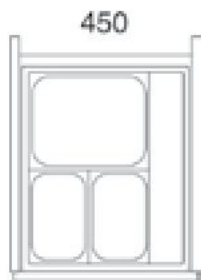

1 3 Bins: (2x8 Litres) +(1x17 Litres)

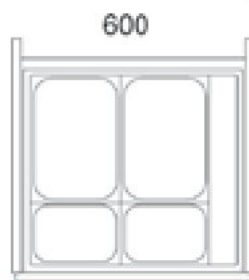

2 4 Bins: (2x 8Litres) + (2x17 Litres)

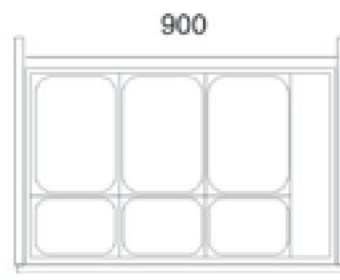

3 6 Bins: (3x8 Litres) + (3x17 Litres)

Dimensions in mm

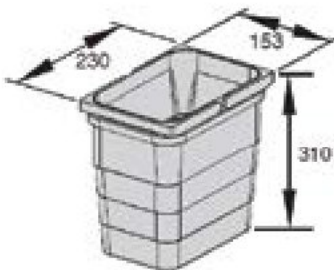

8 litres

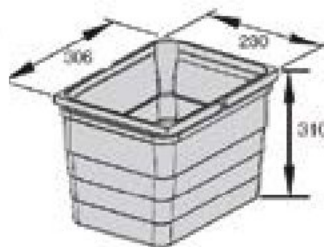

17 litres



4 SERVO DRIVE UNO

ORDERING INFORMATION

Product Description	Capacity	Finish	Article No.
1 Set of 3 waste bins & non slip base plate for installation in drawer boxes	3 Bins: (2x8 Litres) + (1x17 L)	Aluminium Grey	502.91.040
2 Set of 4 waste bins & non slip base plate for installation in drawer boxes	4 Bins: (2x 8 Litres) + (2x17 L)	Aluminium Grey	502.91.041
3 Set of 6 waste bins & non slip base plate for installation in drawer boxes	6 Bins: (3x8 Litres) + (3x17 L)	Aluminium Grey	502.91.050
4 SERVO DRIVE UNO for Drawer Mounted Waste Bins			554.99.092

Sort & Go Waste Bin Set



- **Type:** Built-in Waste Bin
- **Total available capacity:** 24 Litres / 32 Litres
- **Variant:** 2 Bins (2 × 12 Litres) and 2 Bins (2 × 16 Litres)
- **Material:** High grade plastic
- **Colour:** Mint and Grey
- Set fits easily into almost any cabinet without any load falling onto the door hinges due to the self-supporting mounting frame
- Wastebins come out of the cabinet when opened, providing complete accessibility
- Compact and space-saving design
- Sturdy handle and convenient grip on the base makes cleaning and emptying the bins easier
- Stay-Open Lid feature keeps the lid in the open position
- 10 year guarantee

Please Note: While the Sort and Go built-in set is available in a pair, you can also choose to order Sort & Go stand-alone bins. The stand-alone bins are available in an option of 6, 12 and 16 Litres. The 6-litre bin with stay-open lid is perfect for disposal of organic waste right on the kitchen counter while the 12 and 16-litre bins can be used for bottles, cans, packaging or anything else you want sorted. These bins can also be easily mounted on the wall. All bins have their own easy-fix wall mount (enclosed) and are easy to take off and hang back again.



1 Sort & Go Built-in-Set



Sort & Go Stand-alone Bins (Grey)



Sort & Go Stand-alone Bins (Mint)

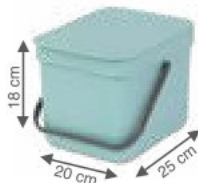

2 6 Litres



3 12 Litres



4 16 Litres

ORDERING INFORMATION

Product Description	Dimensions (W x D x H) mm	Capacity	Finish	Article No.
1 Sort & Go Bin Set	200 x 250 x 400	32 L (2x16)	Mint Grey	502.22.502
2 Sort & Go Waste Bin	200 x 250 x 180	6 L	Mint	502.22.090
			Grey	502.22.590
3 Sort & Go Waste Bin	200 x 250 x 350	12 L	Mint	502.22.091
			Grey	502.22.591
4 Sort & Go Waste Bin	200 x 250 x 400	16 L	Grey	502.22.592

Swing-Out Bins

- **Type:** Built-in Waste Bin
- **Total available capacity:** 15 Litres
- **Material:** Pre-coated Stainless Steel Grade 304
- **Colour:** Brilliant Steel and White
- Set fits easily into almost any cabinet without any load falling onto the door hinges due to the self-supporting mounting frame
- Easy operation as the lid opens and closes automatically when opening and closing the cupboard door
- Waste bin comes out of the cabinet when opened, providing complete accessibility
- Compact and space-saving design
- **Minimum built-in space:**
 - Height: 350 mm
 - Width: 369 mm
 - Depth: 475 mm



1 Brilliant Steel

ORDERING INFORMATION

Product Description	Dimensions mm	Capacity	Finish	Article No.
1 Swing-Out Bins	Ø 293 x 347 (H)	15 L	Brilliant Steel	503.78.115

Deck Mounted Waste Bin



- **Type:** Worktop Waste Bin
- **Total available capacity:** 11 Litres
- **Installation:** Surface mounted or recess mounted
- **Material:** Black plastic bin, stainless steel lid, soft rubber ring and stainless steel ring
- Compact and space-saving design
- Easy access to dispose organic waste while cooking
- In case of recess mounting, cut a \varnothing 285 mm hole in the worktop

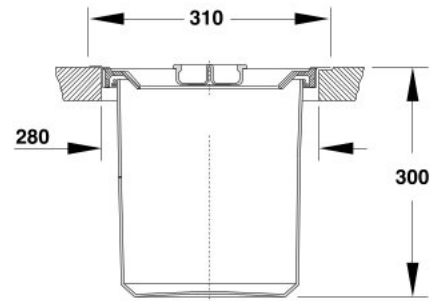

1 Deck Mounted Waste Bin - 11 litres

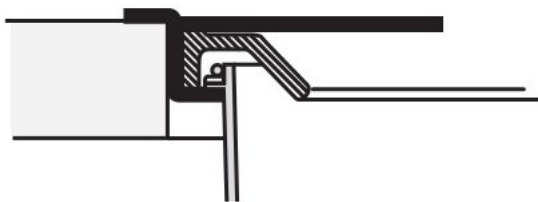

Surface Mounted

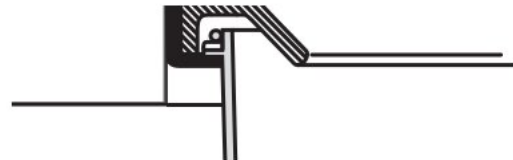

Recess Mounted

ORDERING INFORMATION

Product Description	Dimensions (W x D x H) mm	Capacity	Finish	Article No.
1 Deck mounted waste bin	280 x 310 x 300	11 L	Stainless Steel	502.94.000

Bioboy Waste Bin

- **Type:** Worktop Waste Bin
- **Total available capacity:** 4.2 Litres
- **Suitable door thickness:** 16-22 mm
- **Material:** High grade plastic
- Compact and space-saving design
- Hooks over the top of the cupboard door and the fitting under the worktop and provides easy access to dispose organic waste while cooking
- Keeps the worktop hygienic at all times and keeps the unpleasant smells at bay by simply closing the lid
- Easy to clean



Front view



Rear view



ORDERING INFORMATION

Product Description	Dimensions (W x D x H) mm	Capacity	Finish	Article No.
1 BioBoy Waste Bin	227 x 172 x 170	4.2 L	Grey	502.47.991

Detergent Rack & Waste Bin Holder



Häfele's new pull-out and storage systems add convenience and functionality to your kitchens. The new detergent storage systems from Häfele fit snugly into your under-sink cabinets and prove to be an ideal solution for storing detergents and other cleaning agents.

Bottom Mounted Detergent Pull-out:

This Detergent Pull-out is fixed on the base of the under-sink cabinet and comes with an integrated dampened self-closing technology. The mild steel wire baskets are chrome-plated and can carry weight loads up to 30 kgs. The frame and rails are grey-powder coated and perfectly complement the baskets in finish and elegance.

Specifications:

- Ideal for cabinet width of 400 mm (minimum cabinet width: 300 mm)
- **Load carrying capacity:** 30 kgs
- **Finish:** **Wire basket:** Chrome plated
Frame: Grey-powder coated

Side Mounted Detergent Pull-out:

An alternate option to choose is the side-mounted detergent storage baskets. These baskets can be fixed either on the left or right vertical of the under-sink cabinet with the help of fixing brackets. The mild steel wire baskets are chrome-plated and can carry weight loads up to 30 kgs.

You can also choose to mount this system on runners and convert the application into a pull-out system (runners included).

Specifications:

- Ideal for cabinet width of 300 mm
- **Load carrying capacity:** 30 kgs
- **Finish:** Chrome plated



1 Bottom Mounted Detergent Rack



2 Side Mounted Detergent Rack

ORDERING INFORMATION

Product Description	Dimensions mm	Capacity	Finish	Article No.
1 Bottom Mounted Detergent Rack for Cabinet Width of 400 mm	466 x 286 x 475	30 kgs	Chrome plated	549.35.271
2 Side Mounted Detergent Rack for Cabinet Width of 300 mm	470 x 235 x 390	30 kgs	Chrome plated	549.30.293

Under Sink Detergent Pullout

- Convenient access to cleaning material.
- Slides out easily.
- Weight bearing capacity 15 kgs + 1 Ltr (Additional tray).
- Made out of high grade plastic

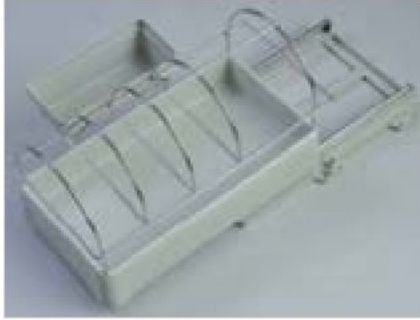

1 Under sink detergent pullout

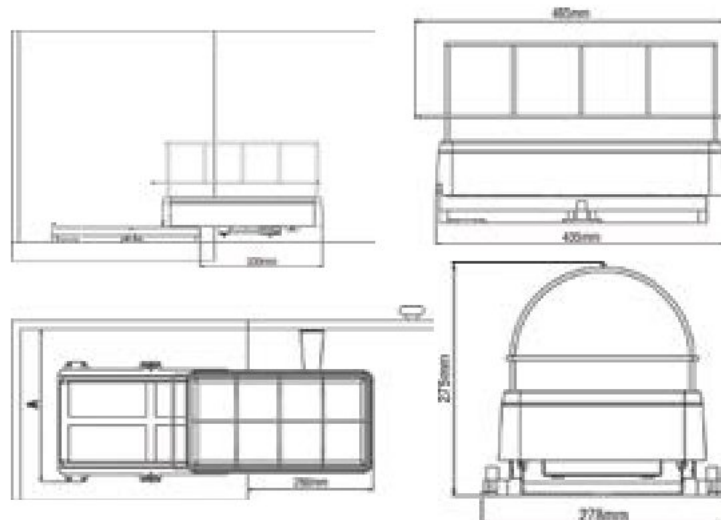

ORDERING INFORMATION

Product Description	Dimensions (W x D x H) mm	Capacity	Finish	Article No.
1 Under sink detergent pullout	278 x 465 x 275	15 kgs + 1 Ltr (Additional tray)		503.32.593

ALUMINIUM PROFILES





■ 2. Stack Modular Shelving



■ 1. Gola Profile

PROFIN RANGE of Aluminium Profiles

Gone are the days when kitchens had dedicated rooms, which were only used for daily chores like cooking and washing. With the on-going migration in to urban centres the concept of micro- living as a trend is now gaining importance among city dwellers. Separating walls disappear, living spaces merge. These spaces flow in to each other and therefore integrating family and living space with kitchens remains a very popular design option especially in upcoming cities.

An open kitchen layout comes with multiple advantages. It transforms your kitchen in to the pulsating hub of your home enabling easy conversations between your guests and you as you cook and prepare dishes. It also adds a sense of volume to your kitchen. With this layout the kitchen and its

cabinetry need to not only look immaculate but should also carry an individualistic appeal which blurs the lines of distinction between your living spaces. Hafele presents Profin – a new comprehensive range of state-of-the-art Aluminium Profiles that helps you achieve all this and much more. The range consists of 4 different categories of profiles – Gola profiles, Stack Modular Shelving, Rail Door Profiles and Strike Shelving System. These categories exploit an individual's sense of sophistication by proposing exciting design potentials and flawless in integration. These profiles are manufactured using advanced technology with meticulous precision that augments user- friendliness and ensures utmost ease of installation.

■ 3. Rail Door Profiles



■ Strike Shelving System

Finishes:

The Profin Range of Aluminium Profiles and their accessories, across categories, are available in five contemporary finishes – Silver, Graphite, Gold Rose Gold and Dark Bronze. Whether you opt for a dark kitchen or follow the recent trend of adapting metallic hues, our versatile range of profiles blends in perfectly with all color schemes. When used in contrast, they stand out like jeweled embellishments that radiates across the kitchen.

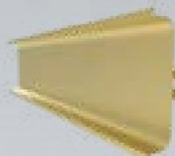

Gold



Dark Bronze



Silver



Rose Gold



Graphite

Profin Horizontal Gola Profile : Product Range

APPLICATION

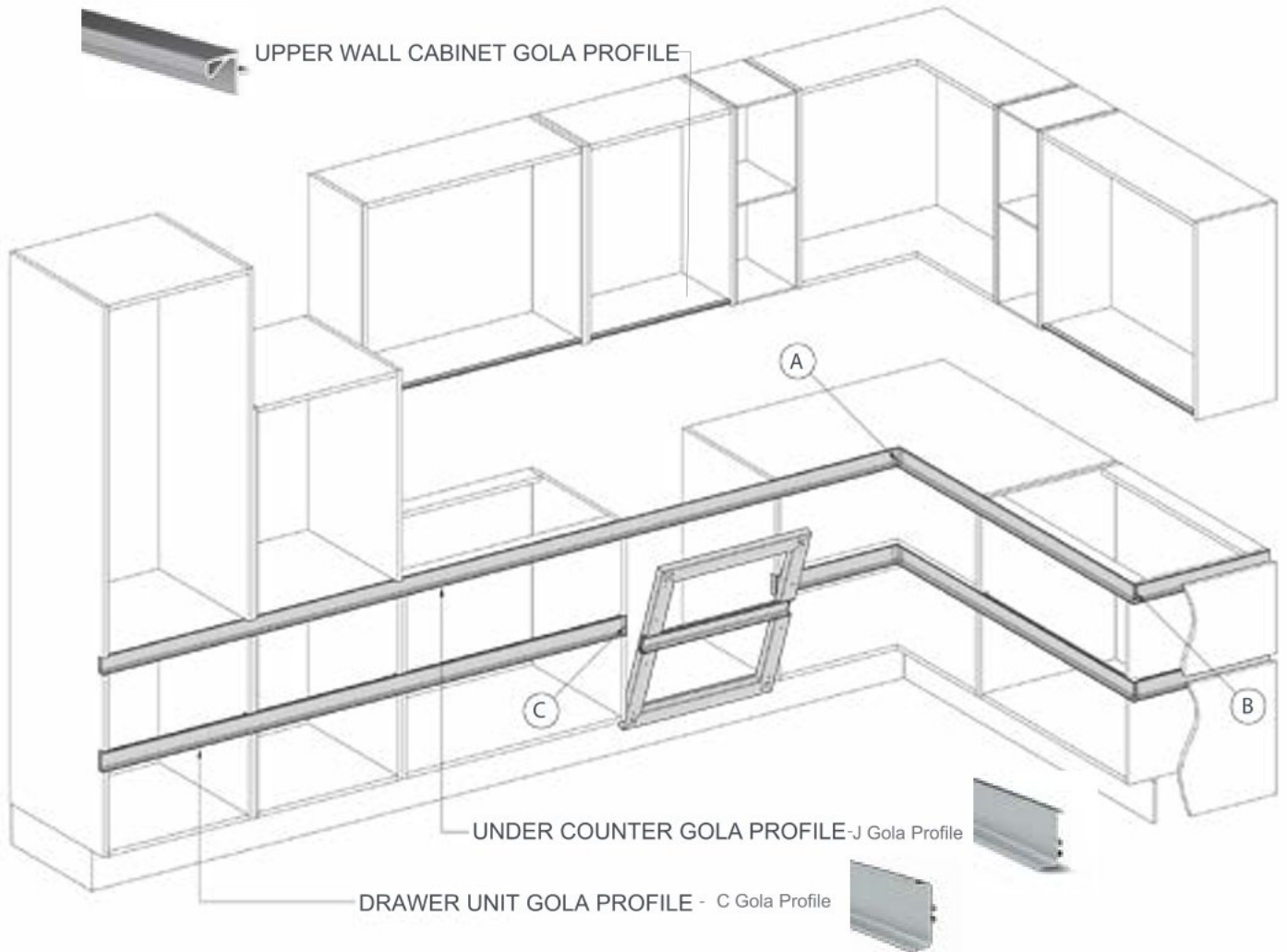

(A) INTERNAL CORNER CONNECTORS

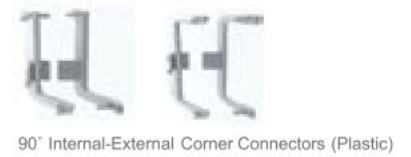
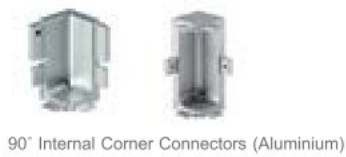

(B) EXTERNAL CORNER CONNECTORS



(C) TRIM CAPS



Profin - Under Counter J Gola Profile

Extensive surfaces, straight-cut designs and handle-less fronts – these furniture developments are trending. Häfele's Profin Range of Aluminium Profiles offers its diverse assortment of Gola Profiles which, thanks to its versatility, makes it possible to satisfy every aesthetic and construction need of contemporary kitchens. You can achieve a seamless handle-less kitchen cabinetry construction with our new Horizontal and Vertical Gola Profiles. The installation of these profiles is extremely simple and easy due to the inventive fastening system.

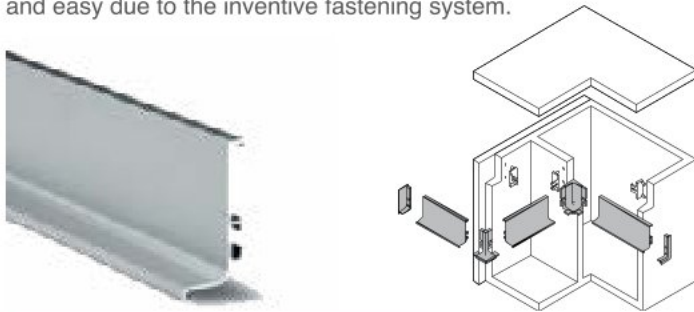

Profin - Under Counter J Gola Profile

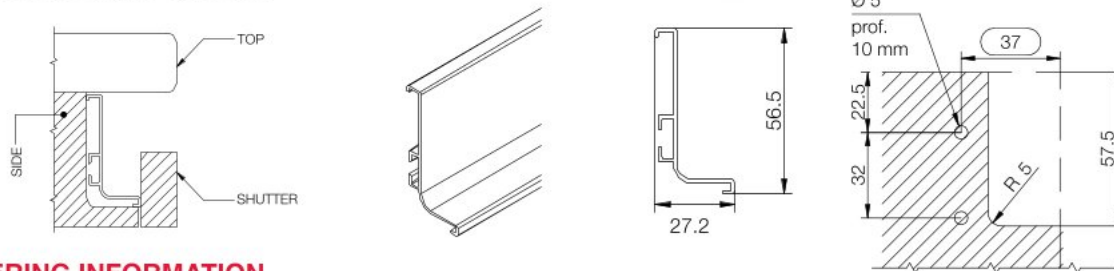

ORDERING INFORMATION

Product Description	Article No.
1 Profin - Under Counter J Gola Profile, Finish: Dark Bronze, Length: 3000 mm; Usable Length: 2800 mm	126.37.909
2 Profin - Under Counter J Gola Profile, Finish: Silver, Length: 3000 mm; Usable Length: 2800 mm	126.37.902
3 Profin - Under Counter J Gola Profile, Finish: Graphite, Length: 3000 mm; Usable Length: 2800 mm	126.37.903
4 Profin - Under Counter J Gola Profile, Finish: Gold, Length: 3000 mm; Usable Length: 2800 mm	126.37.904
5 Profin - Under Counter J Gola Profile, Finish: Rose Gold, Length: 3000 mm; Usable Length: 2800 mm	126.37.906

Unit- Piece

Accessories For J Gola Profile

Profin - 90° Internal Corner Connector - J Gola Profile



Profin - 90° Internal Corner Connector - J Gola Profile

Instruction: No mitre cut (45°) is required for connecting with the profiles

ORDERING INFORMATION

Product Description	Article No.
1 Profin - 90° Internal Corner Connector - J Gola Profile, Finish: Silver	126.36.946
2 Profin - 90° Internal Corner Connector - J Gola Profile, Finish: Graphite	126.36.781
3 Profin - 90° Internal Corner Connector - J Gola Profile, Finish: Gold	126.36.581
4 Profin - 90° Internal Corner Connector - J Gola Profile, Finish: Rose Gold	126.36.881
5 Profin - 90° Internal Corner Connector - J Gola Profile, Finish: Dark Bronze	126.36.181

Unit- Piece

Profin -90° External Corner Connector - J Gola Profile

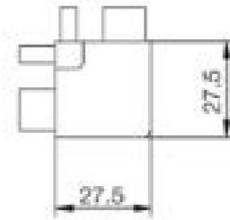
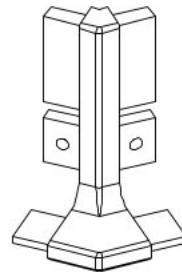

Profin - Under Counter J Gola Profile

Instruction: No mitre cut (45°) is required for connecting with the profiles

ORDERING INFORMATION

Product Description	Article No.
1 Profin - 90° External Connector - J Gola Profile, Finish: Silver	126.36.945
2 Profin - 90° External Connector - J Gola Profile, Finish: Graphite	126.36.782
3 Profin - 90° External Connector - J Gola Profile, Finish: Gold	126.36.582
4 Profin - 90° External Connector - J Gola Profile, Finish: Rose Gold	126.36.882
5 Profin - 90° External Connector - J Gola Profile, Finish: Dark Bronze	126.36.182

Unit- Piece

Profin - 90° Internal-External Corner Connector - J Gola Profile

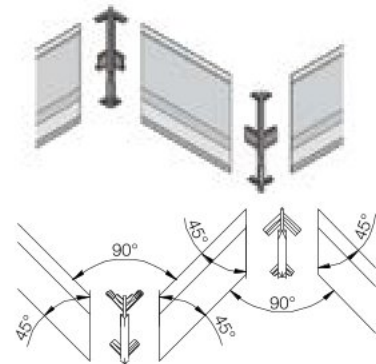

Profin - 90° Internal-External Corner Connector - J Gola Profile

Instruction: Aluminium Profiles have to be mitred (45°) to use these connectors

ORDERING INFORMATION

Product Description	Article No.
1 Profin - 90° Internal-External Corner Connector - J Gola Profile, Finish: Silver	126.37.716
2 Profin - 90° Internal-External Corner Connector - J Gola Profile, Finish: Graphite	126.37.717
3 Profin - 90° Internal-External Corner Connector - J Gola Profile, Finish: Gold	126.37.718
4 Profin - 90° Internal-External Corner Connector - J Gola Profile, Finish: Rose Gold	126.37.719
5 Profin - 90° Internal-External Corner Connector - J Gola Profile, Finish: Dark Bronze	126.37.715

Unit- Piece

Profin - Trim Caps - J Gola Profile

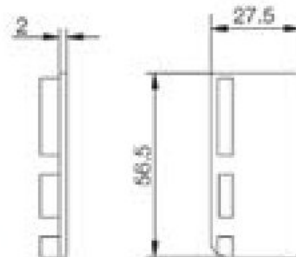

Profin - Trim Caps - J Gola Profile

ORDERING INFORMATION

Product Description	Article No.
1 Profin - Trim Caps - J Gola Profile, Finish: Silver	126.36.947
2 Profin - Trim Caps - J Gola Profile, Graphite	126.36.780
3 Profin - Trim Caps - J Gola Profile, Gold	126.36.580
4 Profin - Trim Caps - J Gola Profile, Rose Gold	126.36.880
5 Profin - Trim Caps - J Gola Profile, Dark Bronze	126.36.180

Unit- Piece

Profin - Drawer Unit Gola Profile

Profin -C Gola Profile



Profin -C Gola Profile

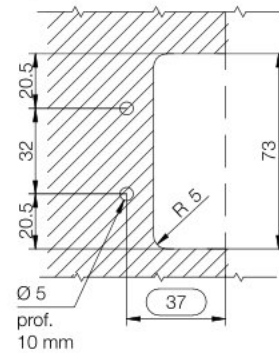
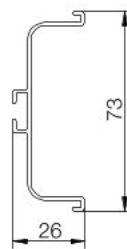
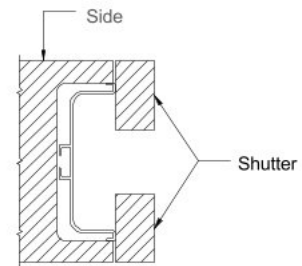
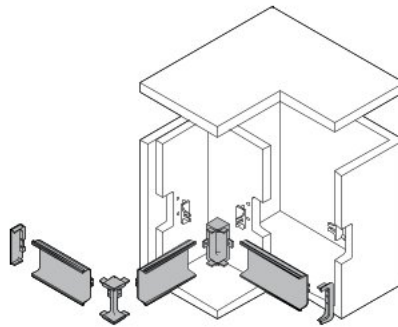
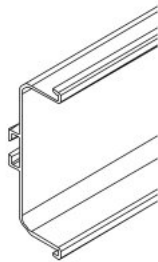

ORDERING INFORMATION

Product Description	Article No.
1 Profin - C Gola Profile, Finish: Silver, Length: 3000 mm, Usable Length: 2800 mm	126.37.926
2 Profin - C Gola Profile, Graphite, Length: 3000 mm, Usable Length: 2800 mm	126.37.927
3 Profin - C Gola Profile, Gold, Length: 3000 mm, Usable Length: 2800 mm	126.37.928
4 Profin - C Gola Profile, Rose Gold, Length: 3000 mm, Usable Length: 2800 mm	126.37.929
5 Profin - C Gola Profile, Dark Bronze, Length: 3000 mm, Usable Length: 2800 mm	126.37.925

Unit- Piece

Accessories For C Gola Profile

Profin - 90° Internal Corner Connector - C Gola Profile

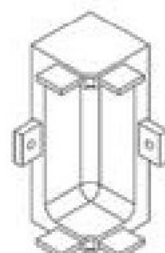

Profin - 90° Internal Corner Connector - C Gola Profile

Instruction: No mitre cut (45°) is required for connecting with the profiles

ORDERING INFORMATION

Product Description	Article No.
1 Profin - 90° Internal Corner Connector - C Gola Profile, Finish: Silver	126.36.985
2 Profin - 90° Internal Corner Connector - C Gola Profile, Finish: Graphite	126.36.784
3 Profin - 90° Internal Corner Connector - C Gola Profile, Finish: Gold	126.36.584
4 Profin - 90° Internal Corner Connector - C Gola Profile, Finish: Rose Gold	126.36.884
5 Profin - 90° Internal Corner Connector - C Gola Profile, Finish: Dark Bronze	126.36.184

Unit- Piece

Profin - 90° External Corner Connector for C Gola Profile

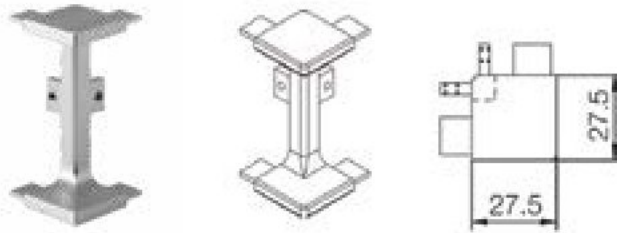

Profin - 90° External Corner Connector for C Gola Profile

Instruction: No mitre cut (45°) is required for connecting with the profiles

ORDERING INFORMATION

Product Description	Article No.
1 Profin - 90° External Corner Connector for C Gola Profile, Finish: Silver	126.37.916
2 Profin - 90° External Corner Connector for C Gola Profile, Finish: Graphite	126.37.917
3 Profin - 90° External Corner Connector for C Gola Profile, Finish: Gold	126.37.918
4 Profin - 90° External Corner Connector for C Gola Profile, Finish: Rose Gold	126.37.919
5 Profin - 90° External Corner Connector for C Gola Profile, Finish: Dark Bronze	126.37.915

Unit- Piece

Profin - 90° Internal-External Corner Connector for C Gola Profile

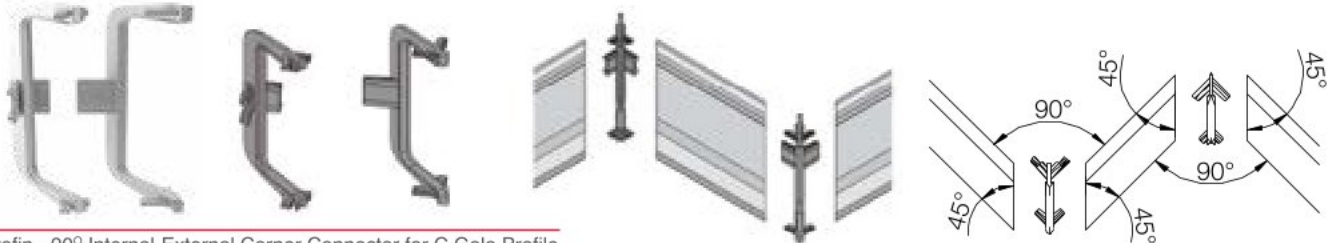

Profin - 90° Internal-External Corner Connector for C Gola Profile

Instruction: Aluminium Profiles have to be mitred (45°) to use these connectors

ORDERING INFORMATION

Product Description	Article No.
1 Profin - 90° Internal-External Corner Connector for C Gola Profile, Finish: Silver	126.37.726
2 Profin - 90° Internal-External Corner Connector for C Gola Profile, Finish: Graphite	126.37.727
3 Profin - 90° Internal-External Corner Connector for C Gola Profile, Finish: Gold	126.37.728
4 Profin - 90° Internal-External Corner Connector for C Gola Profile, Finish: Rose Gold	126.37.729
5 Profin - 90° Internal-External Corner Connector for C Gola Profile, Finish: Dark Bronze	126.37.725

Unit- Pair

Profin - Trim Caps - C Gola Profile

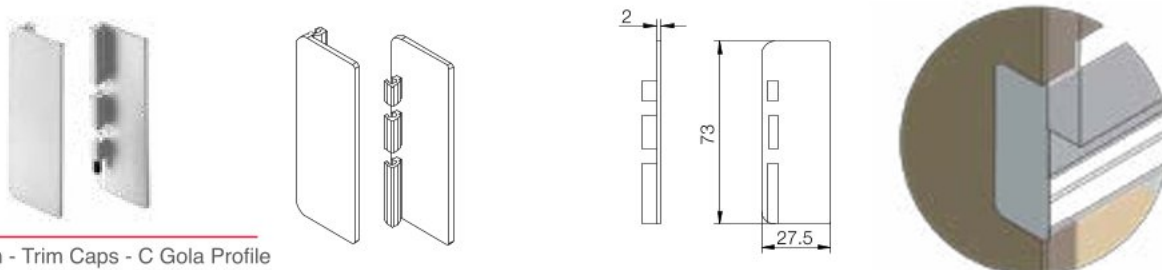

Profin - Trim Caps - C Gola Profile

ORDERING INFORMATION

Product Description	Article No.
1 Profin - Trim Caps - C Gola Profile, Finish: Silver	126.36.986
2 Profin - Trim Caps - C Gola Profile, Finish: Graphite	126.36.783
3 Profin - Trim Caps - C Gola Profile, Finish: Gold	126.36.583
4 Profin - Trim Caps - C Gola Profile, Finish: Rose Gold	126.36.883
5 Profin - Trim Caps - C Gola Profile, Finish: Dark Bronze	126.36.183

Unit- Pair

Quick Support Connector for Profin - J & C Gola Profiles

Screw On

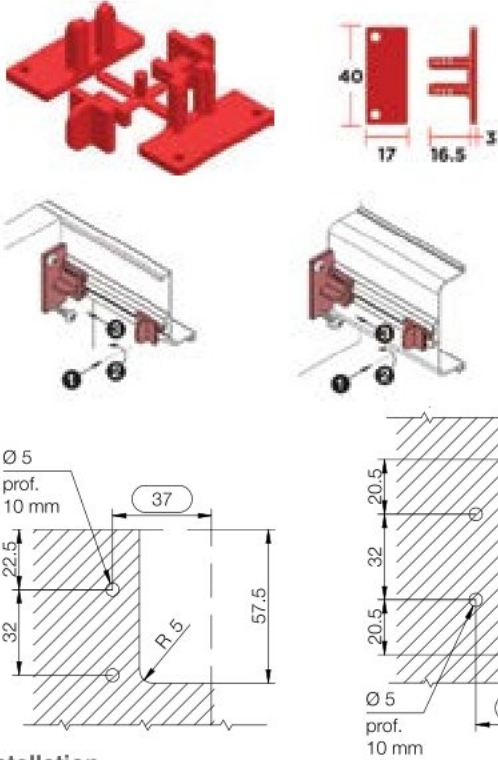

Dowel

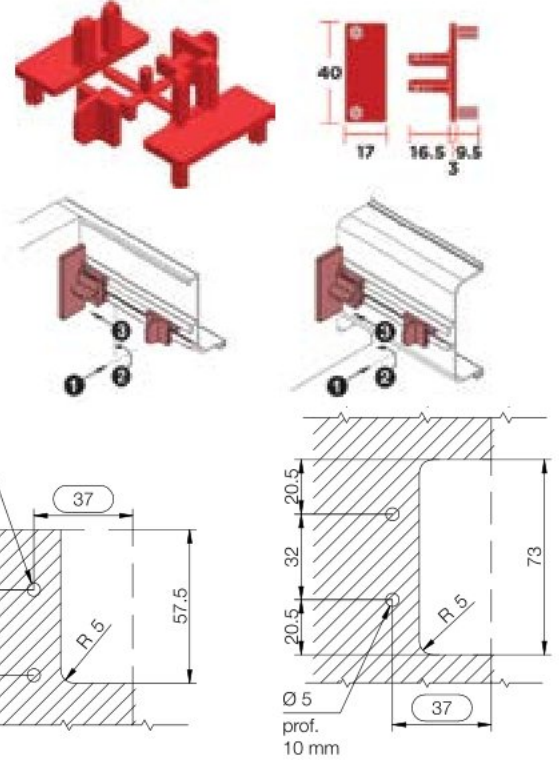

Installation

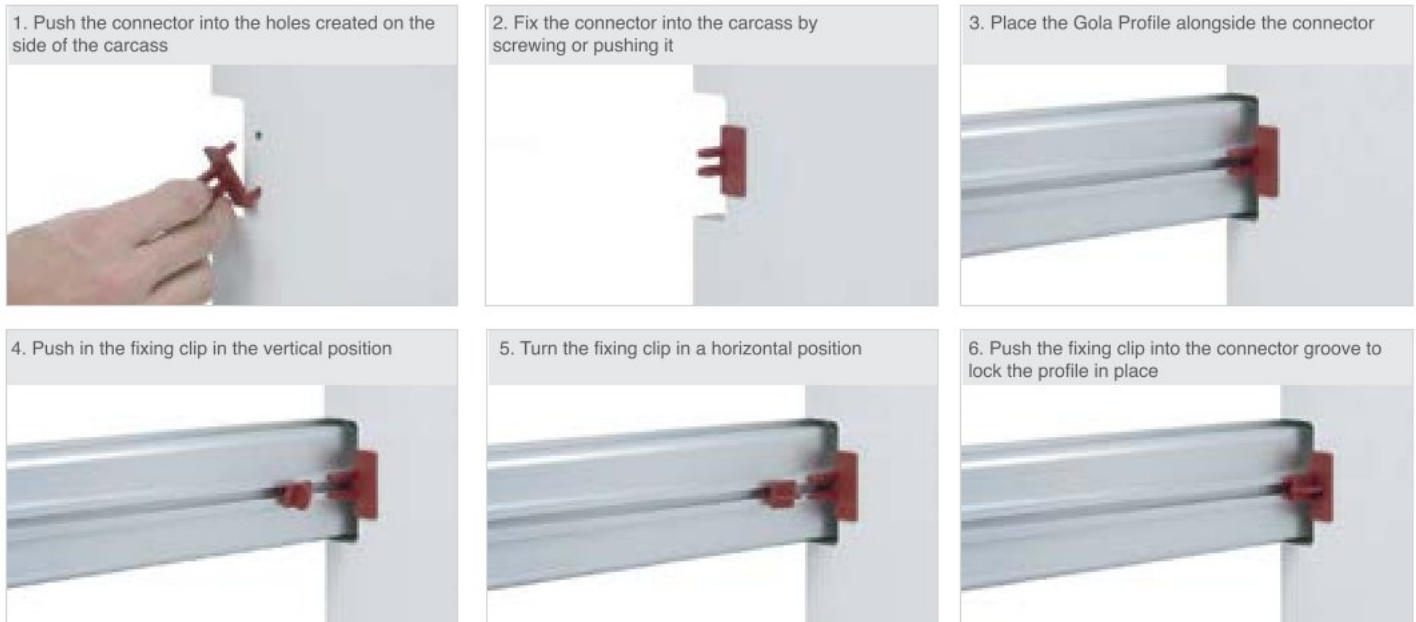

ORDERING INFORMATION

Product Description		Article No.
1	Profin - Quick Support Connector for J & C Gola Profiles, Screw On	712.63.511
2	Profin - Quick Support Connector for J & C Gola Profiles, Dowel	712.63.521

Door Calculations

Cabinet with Undercounter J Gola Profile

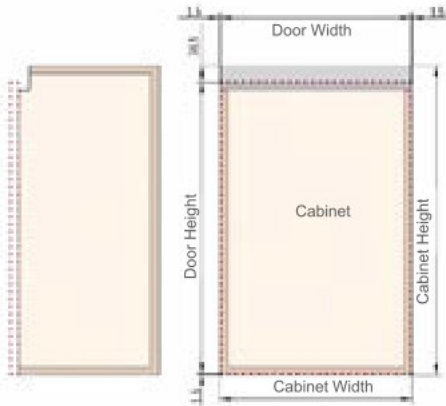

Door Height : Cabinet Height – 40 mm
 Door Width : Cabinet Width – 3 mm

Equal-sized High-fronted Drawers with Undercounter J & Drawer Unit C Gola Profiles

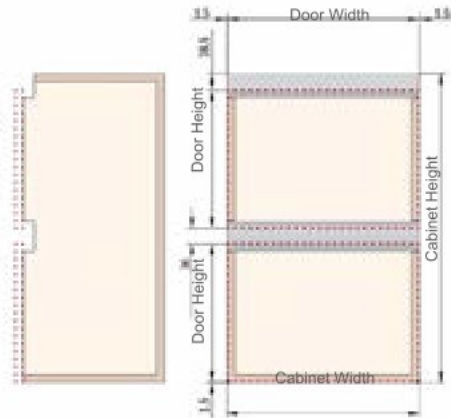

Drawer Height : (Cabinet Height – 76 mm) / 2
 Door Width : Cabinet Width – 3 mm

2 Equal-sized Cutlery Drawers and a High-fronted Drawer with Undercounter J & Drawer Unit C Gola Profiles

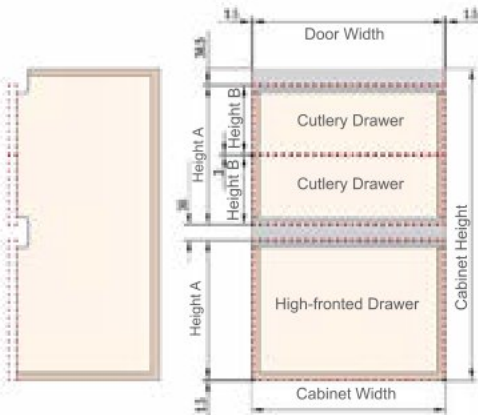

Drawer Height A : (Cabinet Height – 76 mm) / 2
 Drawer Height B : (Drawer Height A – 3) / 2
 Drawer Width : Cabinet Width – 3 mm

Equal-sized High-fronted Drawers with Drawer Unit C Gola Profile

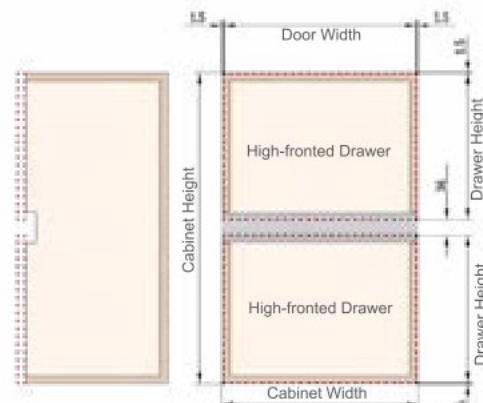

Drawer Height : (Cabinet Height – 39 mm) / 2
 Drawer Width : Cabinet Width – 3 mm

3 Equal, Mid-fronted Drawers with Undercounter J & Drawer Unit C Gola Profiles

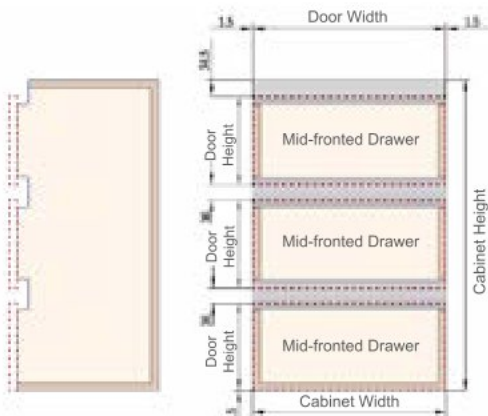

Drawer Height : (Cabinet Height – 112 mm) / 3
 Drawer Width : Cabinet Width – 3 mm

Note: The above mentioned calculations are for reference purposes only. Actual calculations may vary from case-to-case basis.

Profin - Profile for Upper Wall Cabinet



Profin - Profile for Upper Wall Cabinet

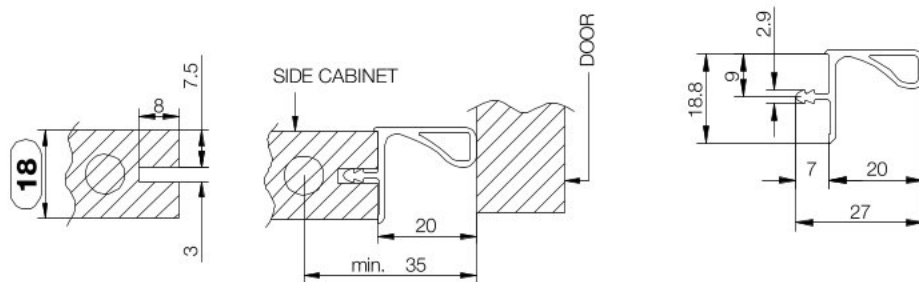
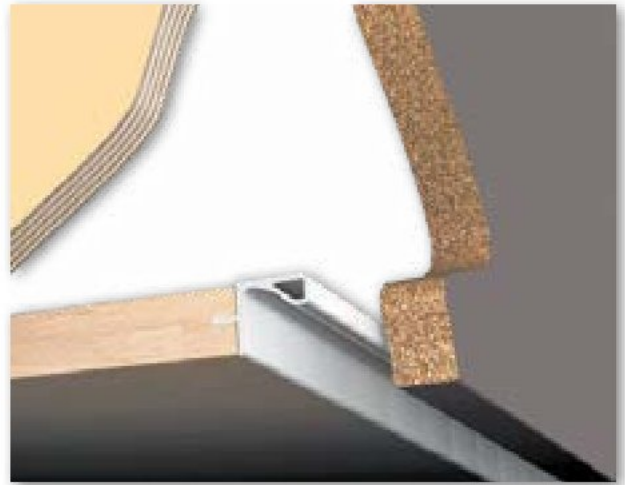

ORDERING INFORMATION

Product Description		Article No.
1	Profin - Profile for Upper Wall Cabinet, Finish: Silver, Length: 3000 mm, Usable Length: 2800 mm	126.37.736
2	Profin - Profile for Upper Wall Cabinet, Finish: Graphite, Length: 3000 mm, Usable Length: 2800 mm	126.37.737
3	Profin - Profile for Upper Wall Cabinet, Finish: Gold, Length: 3000 mm, Usable Length: 2800 mm	126.37.738
4	Profin - Profile for Upper Wall Cabinet, Finish: Rose Gold, Length: 3000 mm, Usable Length: 2800 mm	126.37.739
5	Profin - Profile for Upper Wall Cabinet, Finish: Dark Bronze, Length: 3000 mm, Usable Length: 2800 mm	126.37.735

Unit- Piece

Profin - Vertical Gola Profile
 Profin - Single/Side Snap - on Vertical Gola Profile

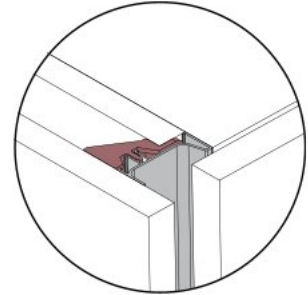
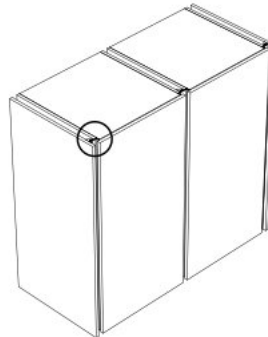
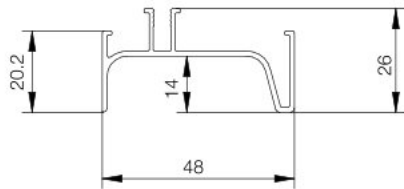

Profin - Single/Side Snap
 - on Vertical Gola Profile

Note: These vertical profiles snap onto special brackets, which ensure firm coupling between the two components

ORDERING INFORMATION

Product Description	Article No.
1 Profin - Single/Side Snap - on Vertical Gola Profile Finish: Dark Bronze, Length: 2400 mm	126.37.970
2 Profin - Single/Side Snap - on Vertical Gola Profile Finish: Silver, Length: 2400 mm	126.37.971
3 Profin - Single/Side Snap - on Vertical Gola Profile Finish: Graphite, Length: 2400 mm	126.37.972
4 Profin - Single/Side Snap - on Vertical Gola Profile Finish: Gold, Length: 2400 mm	126.37.973
5 Profin - Single/Side Snap - on Vertical Gola Profile Finish: Rose Gold, Length: 2400 mm	126.37.974

Unit- Piece

Profin - Double / Intermediate Snap-on Vertical Gola Profile

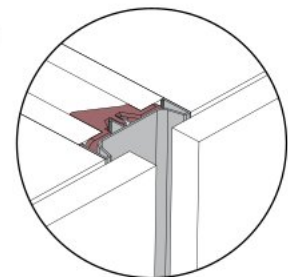
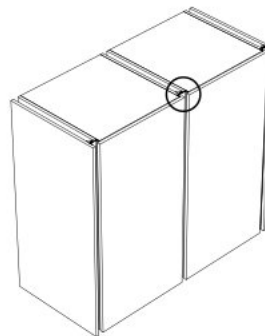
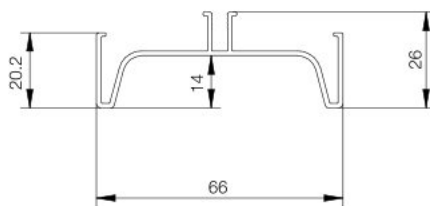

Profin - Double / Intermediate
 Snap-on Vertical Gola Profile

Note: These vertical profiles snap onto special brackets, which ensure firm coupling between the two components

ORDERING INFORMATION

Product Description	Article No.
1 Profin - Double / Intermediate Snap-on Vertical Gola Profile, Finish: Dark Bronze, Length: 2400 mm	126.37.945
2 Profin - Double / Intermediate Snap-on Vertical Gola Profile, Finish: Silver, Length: 2400 mm	126.37.946
3 Profin - Double / Intermediate Snap-on Vertical Gola Profile, Finish: Graphite, Length: 2400 mm	126.37.947
4 Profin - Double / Intermediate Snap-on Vertical Gola Profile, Finish: Gold, Length: 2400 mm	126.37.948
5 Profin - Double / Intermediate Snap-on Vertical Gola Profile, Finish: Rose Gold, Length: 2400 mm	126.37.949

Unit- Piece

Profin - Oven Protector for Side & Intermediate Vertical Gola Profiles

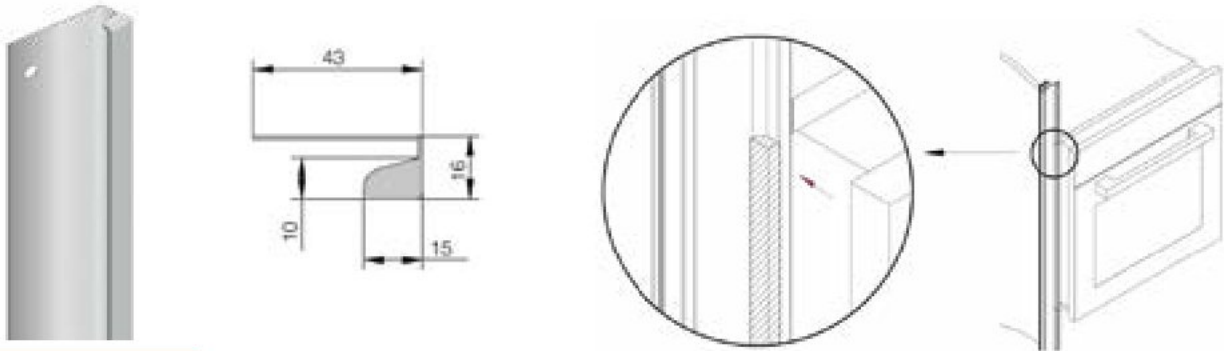

Profin - Oven Protector for Side & Intermediate Vertical Gola Profiles

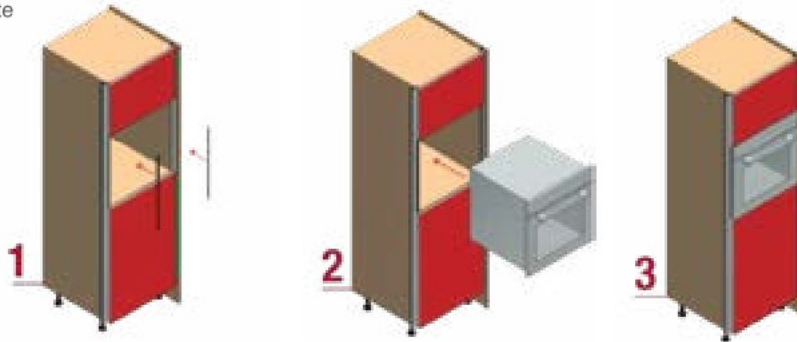

ORDERING INFORMATION

Product Description	Article No.
1 Profin - Oven Protector for Side & Intermediate Vertical Gola Profiles, Finish: Dark Bronze, Length: 580 mm	126.36.217
2 Profin - Oven Protector for Side & Intermediate Vertical Gola Profiles, Finish: Silver, Length: 580 mm	126.36.218
3 Profin - Oven Protector for Side & Intermediate Vertical Gola Profiles, Finish: Graphite, Length: 580 mm	126.36.219
4 Profin - Oven Protector for Side & Intermediate Vertical Gola Profiles, Finish: Gold, Length: 580 mm	126.36.220
5 Profin - Oven Protector for Side & Intermediate Vertical Gola Profiles, Finish: Rose Gold, Length: 580 mm	126.36.221

Unit- Piece

Profin - Brackets for Side and Intermediate Snap-on Vertical Gola Profile

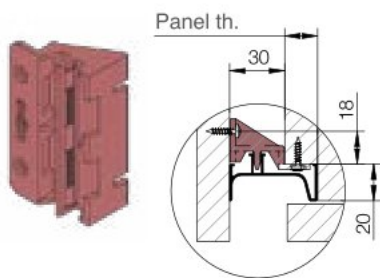

1 For Side Snap-on Gola Profile

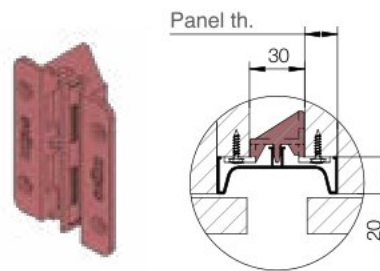

2 For Intermediate Snap-on Gola Profile

Note: The fixing of these brackets is on the front edge thereby eliminating the need of internal screwing and providing cleaner aesthetics inside the cabinet.

ORDERING INFORMATION

Product Description	Article No.
1 Profin - Brackets for Side and Intermediate Snap-on Vertical Gola Profile, For Side Snap-on Vertical Gola Profile	126.37.966
2 Profin - Brackets for Side and Intermediate Snap-on Vertical Gola Profile, For Intermediate Snap-on Vertical Gola Profile	126.37.965

Unit- Piece

Profin - Rear Brackets for Side and Intermediate Snap-on Vertical Gola Profile

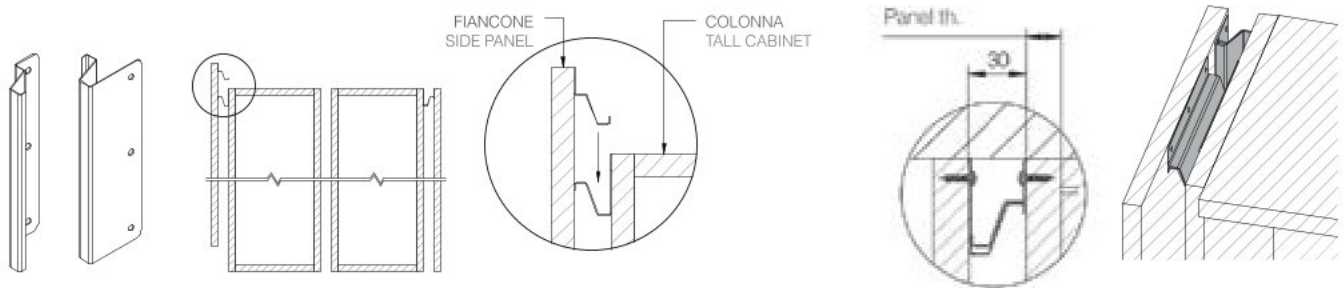

1 Profin - Rear Brackets for Side and Intermediate Snap-on Vertical Gola Profile

INSTALLATION

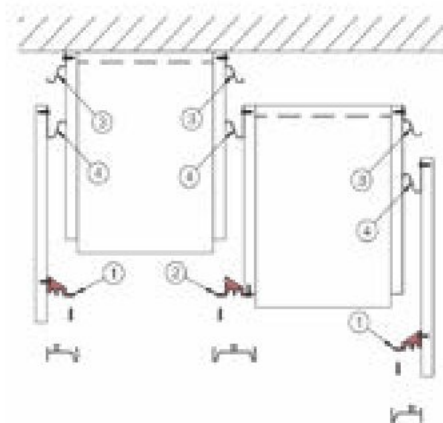
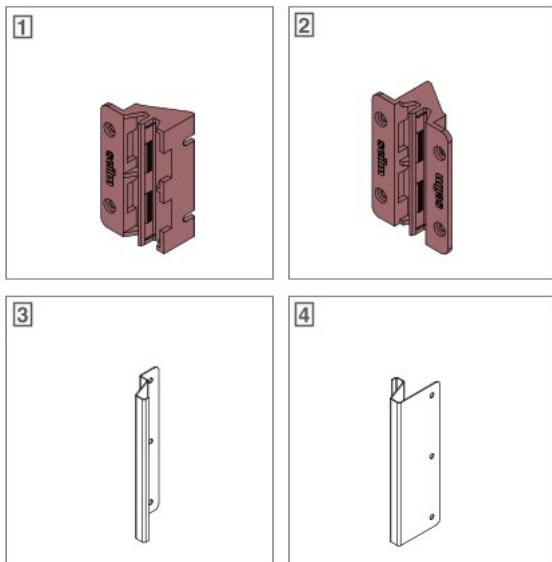

HINGE INSTALLATION DETAILS

- The gap between holes for installing a Cross Mounting Plate and Straight Mounting Plate should be 37 mm and 20-22 mm respectively from the front of the unit
- Hinges with Cross Mounting Plates should hence always be used with Gola Profiles
- Straight Mounting Plates can only be used on side panels without a Gola Profile

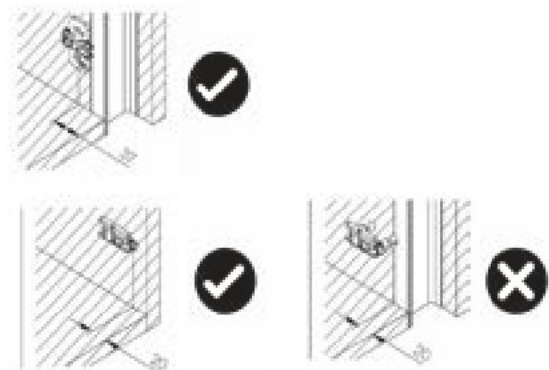

ORDERING INFORMATION

Product Description	Article No.
Profin - Rear Brackets for Side and Intermediate Snap-on Vertical Gola Profile	126.37.967

Unit- Pair

Profin - Stack Modular Shelving

For Decorative Open Shelving System

A new design concept of open shelving / cabinet systems is emerging. More and more enclosed storage areas in the kitchen seem to be fading into this new design concept. The open spaces are increasingly being used as platforms to showcase kitchenware, curated statement pieces of art or accessories. Häfele presents its Profin Range of Stack Modular Shelving Profiles that shapes your entire furniture aesthetics while silently delivering strength, stability and function to the units. These profiles and their accessories enable construction of open shelves with glass or wood and emanate elegance with their sleek and faultless built and finish.



Silver



Graphite



Gold



Rose Gold



Dark Bronze

Components

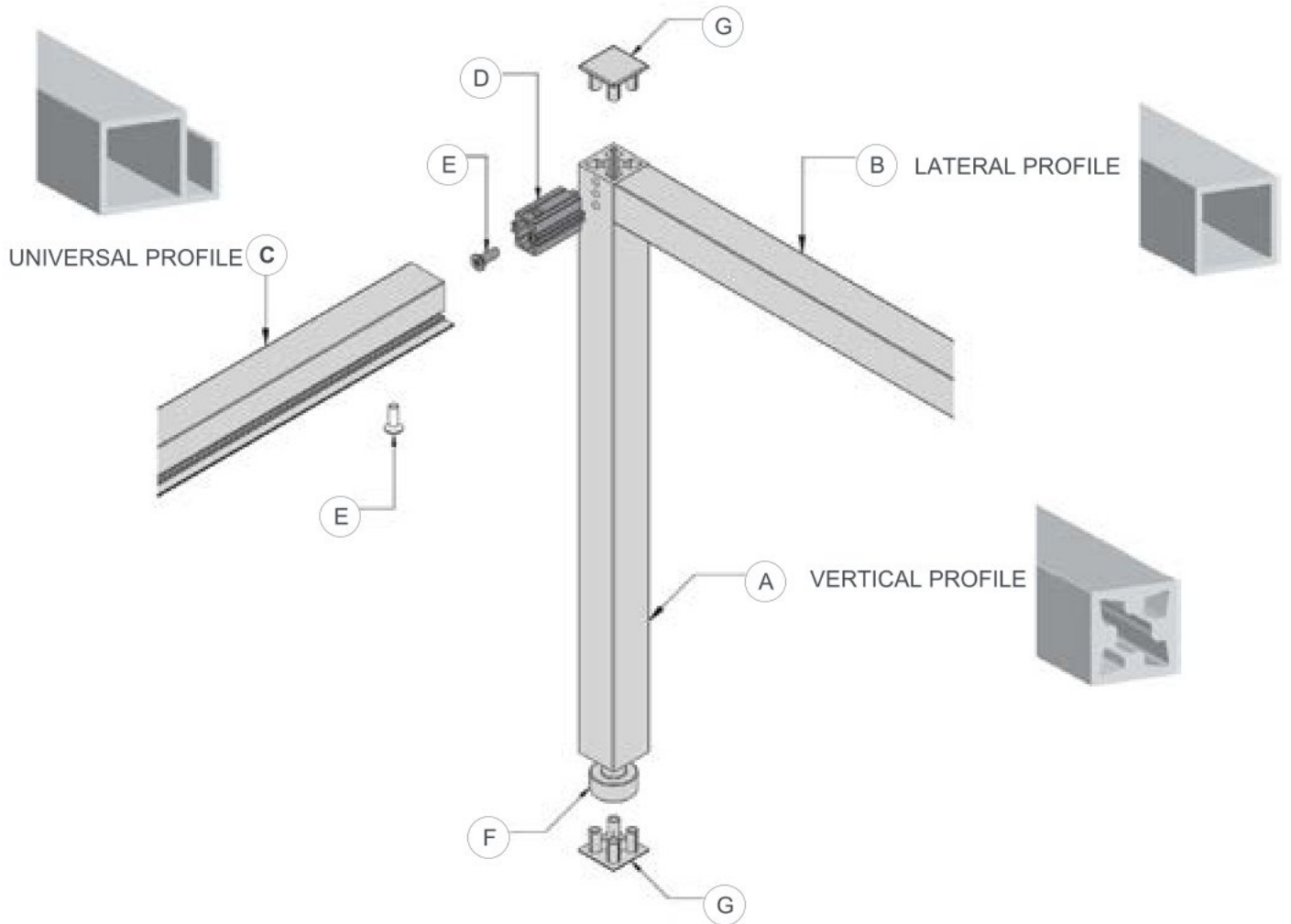

(D) & (E) JOINING BLOCK AND UNIVERSAL SCREW



(F) LEVELER



(G) COVER CAP



Profin - Stack Modular Shelving System

A. Profin - Vertical Profile, Length: 2670mm, Usable Length: 2450 mm

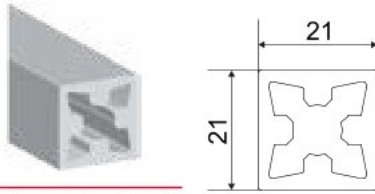

Profin - Vertical Profile

ORDERING INFORMATION

Product Description	Article No.
1 Profin - Vertical Profile, Finish: Dark Bronze, Length: 2670mm	793.10.102
2 Profin - Vertical Profile, Finish: Silver, Length: 2670mm	793.10.902
3 Profin - Vertical Profile, Finish: Graphite, Length: 2670mm	793.10.302
4 Profin - Vertical Profile, Finish: Gold, Length: 2670mm	793.10.502
5 Profin - Vertical Profile, Finish: Rose Gold, Length: 2670mm	793.10.402

Unit: Piece

B. Profin - Lateral Profile, Length: 2670mm

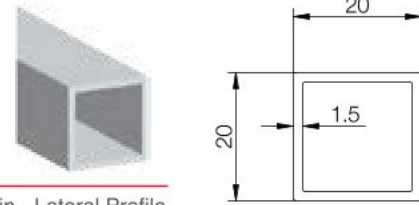

Profin - Lateral Profile

ORDERING INFORMATION

Product Description	Article No.
1 Profin - Lateral Profile, Finish: Dark Bronze, Length: 2670 mm	793.10.112
2 Profin - Lateral Profile, Finish: Silver, Length: 2670 mm	793.10.912
3 Profin - Lateral Profile, Finish: Graphite, Length: 2670 mm	793.10.312
4 Profin - Lateral Profile, Finish: Gold, Length: 2670 mm	793.10.512
5 Profin - Lateral Profile, Finish: Rose Gold, Length: 2670 mm	793.10.412

Unit: Piece

C. Profin - Universal Profile, Length : 2670mm, Usable Length : 2450 mm

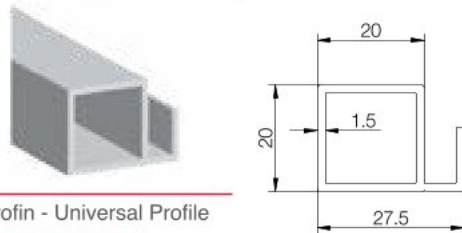

Profin - Universal Profile

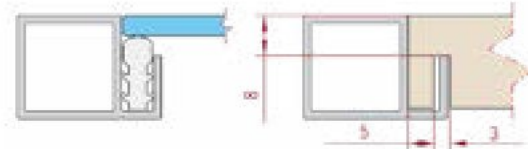

ORDERING INFORMATION

Product Description	Article No.
1 Profin - Universal Profile, Finish: Dark Bronze, Length: 2670mm	793.10.122
2 Profin - Universal Profile, Finish: Silver, Length: 2670mm	793.10.922
3 Profin - Universal Profile, Finish: Graphite, Length: 2670mm	793.10.322
4 Profin - Universal Profile, Finish: Gold, Length: 2670mm	793.10.522
5 Profin - Universal Profile, Finish: Rose Gold, Length: 2670mm	793.10.422

Unit: Piece

ACCESSORIES FOR PROFILES

D. Profin - Joining Block for Profile & Drilling Template for Vertical Profile



1 Profin - Joining Block

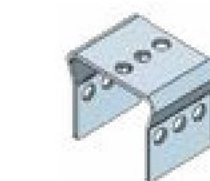
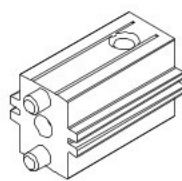

2 Drilling Template

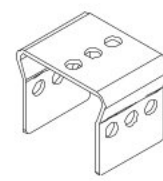

ORDERING INFORMATION

Product Description	Article No.
1 Profin - Joining Block for Profile, Finish: Zinc Plated	793.10.991
2 Profin - Drilling Template for Vertical Profile, Finish: Nickel Plated	793.10.996

Unit: Piece

E. Profin - Universal Screw

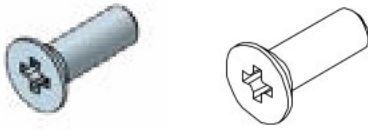

Profin - Universal Screw

ORDERING INFORMATION

Product Description	Article No.
1 Profin - Universal Screw, Finish: Darkened	793.10.992
2 Profin - Universal Screw, Finish: Nickel Plated	793.10.993
3 Profin - Universal Screw, Finish: Zinc Plated	793.10.994

Unit: Piece

G. Profin - Cover Cap

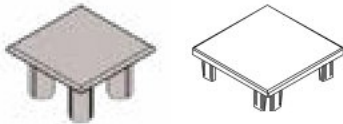

Profin - Cover Cap

ORDERING INFORMATION

Product Description	Article No.
1 Profin - Cover Cap, Finish: Dark Bronze	793.10.190
2 Profin - Cover Cap, Finish: Silver	793.10.990
3 Profin - Cover Cap, Finish: Graphite	793.10.390
4 Profin - Cover Cap, Finish: Gold	793.10.590
5 Profin - Cover Cap, Finish: Rose Gold	793.10.490

Unit: Piece

F. Profin - Leveller

Adjustable leg Ø20mm, thread M10

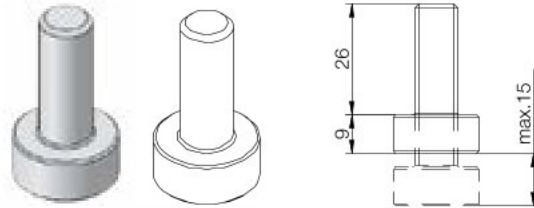

Profin - Leveller

ORDERING INFORMATION

Product Description	Article No.
1 Profin - Leveller, Finish: Nickel Plated	793.10.995

Unit: Piece

H. Profin - Gasket for 4mm Glass

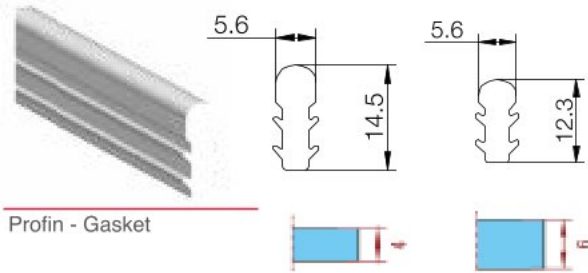

Profin - Gasket

ORDERING INFORMATION

Product Description	Article No.
1 Profin - Gasket For 4 mm Glass Shelf	793.10.980
2 Profin - Gasket For 6 mm Glass Shelf	793.10.981

Unit: 1 Meter

Profin - Stack Modular Shelving System: Technical Information

DRILLING DETAILS

Drilling for Lateral & Universal Profile

For Vertical Profile
By Drawings

By Template

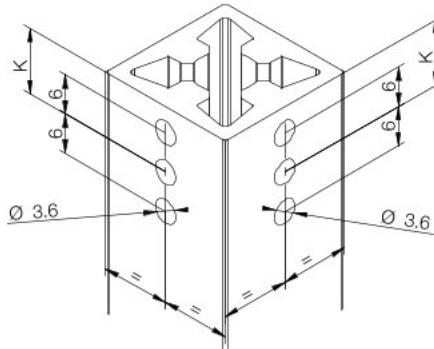
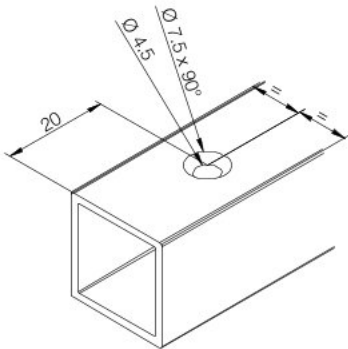

K : 8.7 mm with an end cap at the top
K : 9.7 mm without an end cap at the top

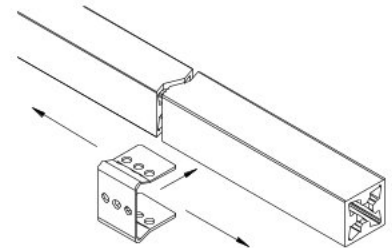

Step 1: Position the template on the profiles

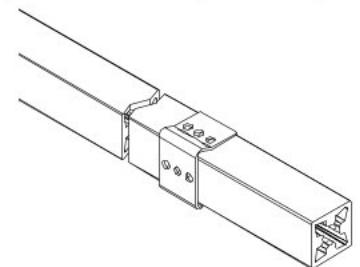

Step 2: Mark the holes, remove the template, drill the profile.

MOUNTING & CONSTRUCTION DETAILS

For Freestanding Application

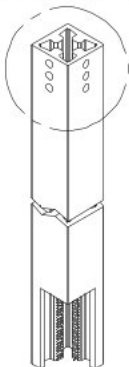

We recommend the use of levelers for a freestanding application. In this case, to install the leveler, thread a M10 hole with a 30 mm depth into the lower part of the vertical profile.

CALCULATIONS

For Glass / Wooden Shelf

Shelf Depth : Structure Depth – 42mm

Shelf Width : Structure Width – 42mm

Note: The Stack Profiles give you the freedom to design the structure as per your requirement, with no depth, height or width restrictions. It is therefore not possible for us to ascertain the maximum weight carrying capacity. This needs to be determined by the fabricator depending on the dimensions of the structure. These Profiles are not meant for heavy shelving.

For Wall Mounting Application

Method 1

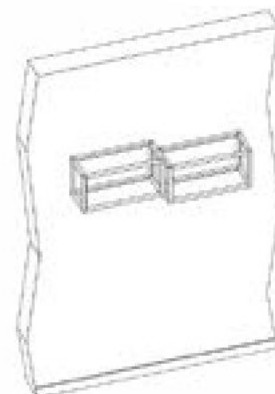
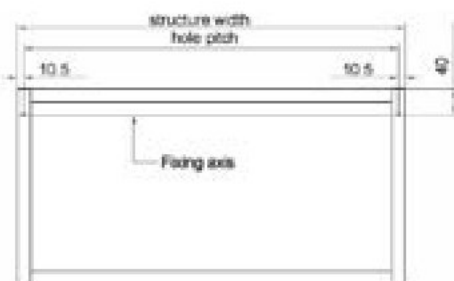

Drill holes of \varnothing 4.5 mm on the vertical profile in the position demonstrated in the drawing. The type of hole to be drilled depends on the fixing screw - Type A or Type B (details on the next page).

- Mark the height on the wall from the floor, where you want to mount the structure
- Mark the fixing axis and the hole pitch
- Drill holes into the wall

DRILLING DETAILS

Type A – Countersunk Hole

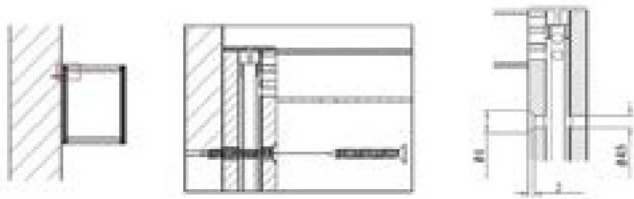

- In Type A, the countersunk screw secures the structure to the wall and flushes in line with the profile
- The screw head will be visible
- No adjustments are possible

Type B – Double Diameter Hole

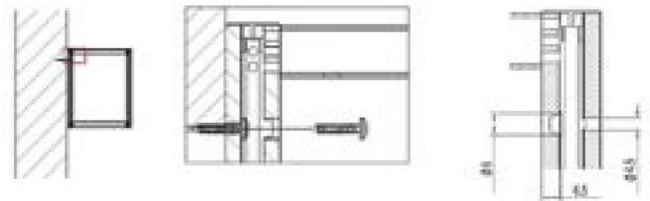

- In Type B, a through hole of diameter 4.5 mm is drilled into the profile. Another hole of diameter 8 mm with a depth of 6.5 mm is drilled into the front part of the back vertical profile
- The dome-head screw passes through the bigger hole into the diameter 4.5 mm hole and secures the structure to the wall
- The screw head will not be visible (if a cover cap is used to conceal the diameter 8 mm hole)
- Adjustment of 1 mm will be possible

Method 2

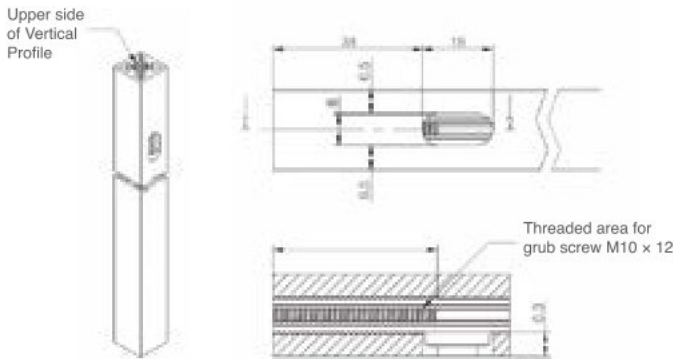

- Thread the Vertical Profile from the top to a height of 40 mm
- Cut an oval hole as per the dimensions provided in the diagram

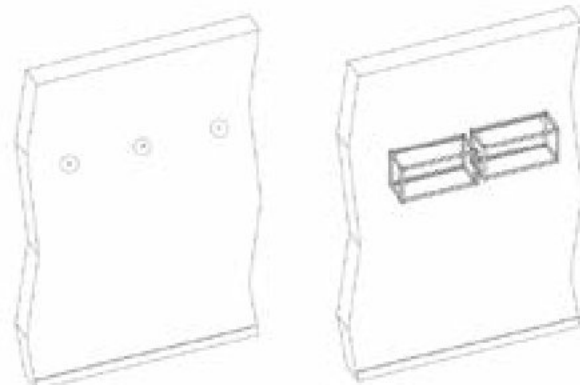

- Drill holes in the wall using a diameter 6 mm drill bit to a minimum depth of 40 mm
- Insert the dowels (not included in the offering) in the holes drilled
- Fix the curved hooks (not included in the offering) into the dowel

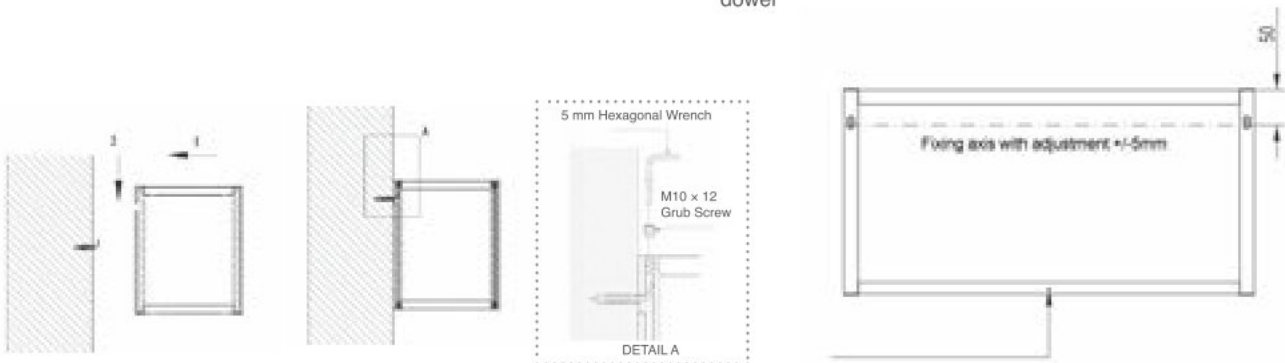

- Bring the assembled structure close to the wall and engage it with the curved hooks
- Once the structure is engaged with the hooks, adjust it to the desired height (can be adjusted to +/- 5mm) and insert the grub screws (not included in the offering) along the threaded rear vertical profiles from the upper side via a hexagonal wrench to tighten the grip and hold the hooks firmly in place

- Once hooked firmly, secure the structure to the wall with a normal screw through the hole (Type A or B) made in the universal profile

Profin - Rail Door Profiles

Decorative Cabinet Doors

Overhead cabinets and tall units are a must in any kitchen, especially in an open kitchen. These systems optimally utilize spaces available within kitchens and can effectively store bulk quantities of food (non-refrigerated) and other kitchen items in an organized way. To impart a similar grace to these systems as your handle-less furniture and open shelving units, Häfele brings to you its Profin Range of Rail Door Profiles. These profiles meander naturally forming innate grooves for the handles and border the glass to perfection thereby crafting timeless designs that never run out of fashion.



Silver



Graphite



Gold



Rose Gold



Dark Bronze

Profin - Rail Door: Profile Door System

Profin - Door Profile (thick)

Length : 3 Meters; Usable Length: 2800 mm

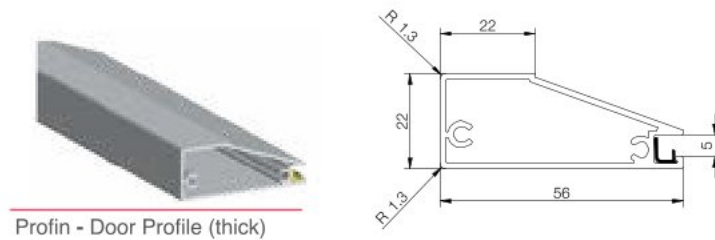

Profin - Door Profile (thick)

ORDERING INFORMATION

Product Description	Article No.
1 Profin - Door Profile (thick), Finish: Dark Bronze, Length: 3000 mm	563.97.113
2 Profin - Door Profile (thick), Finish: Silver, Length: 3000 mm	563.97.913
3 Profin - Door Profile (thick), Finish: Graphite, Length: 3000 mm	563.97.313
4 Profin - Door Profile (thick), Finish: Gold, Length: 3000 mm	563.97.513
5 Profin - Door Profile (thick), Finish: Rose Gold, Length: 3000 mm	563.97.413

Unit: Piece

Profin - Door Profile (thin)

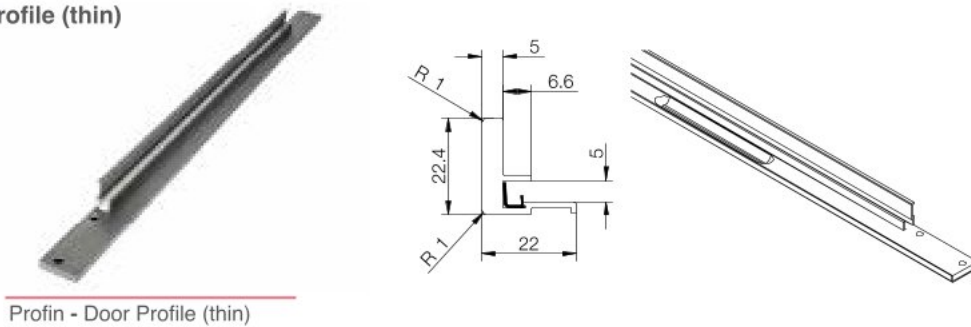

Profin - Door Profile (thin)

ORDERING INFORMATION

Product Description	Article No.
1 Profin - Door Profile (thin), Finish: Dark Bronze, Length: 448 mm	563.97.115
2 Profin - Door Profile (thin), Finish: Dark Bronze, Length: 598 mm	563.97.116
3 Profin - Door Profile (thin), Finish: Dark Bronze, Length: 898 mm	563.97.117
4 Profin - Door Profile (thin), Finish: Dark Bronze, Length: 1198 mm	563.97.118
5 Profin - Door Profile (thin), Finish: Silver, Length: 448 mm	563.97.915
6 Profin - Door Profile (thin), Finish: Silver, Length: 598 mm	563.97.916
7 Profin - Door Profile (thin), Finish: Silver, Length: 898 mm	563.97.917
8 Profin - Door Profile (thin), Finish: Silver, Length: 1198 mm	563.97.918
9 Profin - Door Profile (thin), Finish: Graphite, Length: 448 mm	563.97.315
10 Profin - Door Profile (thin), Finish: Graphite, Length: 598 mm	563.97.316
11 Profin - Door Profile (thin), Finish: Graphite, Length: 898 mm	563.97.317
12 Profin - Door Profile (thin), Finish: Graphite, Length: 1198 mm	563.97.318
13 Profin - Door Profile (thin), Finish: Gold, Length: 448 mm	563.97.515
14 Profin - Door Profile (thin), Finish: Gold, Length: 598 mm	563.97.516
15 Profin - Door Profile (thin), Finish: Gold, Length: 898 mm	563.97.517
16 Profin - Door Profile (thin), Finish: Gold, Length: 1198 mm	563.97.518
17 Profin - Door Profile (thin), Finish: Rose Gold, Length: 448 mm	563.97.415
18 Profin - Door Profile (thin), Finish: Rose Gold, Length: 598 mm	563.97.416
19 Profin - Door Profile (thin), Finish: Rose Gold, Length: 898 mm	563.97.417
20 Profin - Door Profile (thin), Finish: Rose Gold, Length: 1198 mm	563.97.418

Unit: Piece

Profin - Handle for Door Profile (thick) & Handle Screw

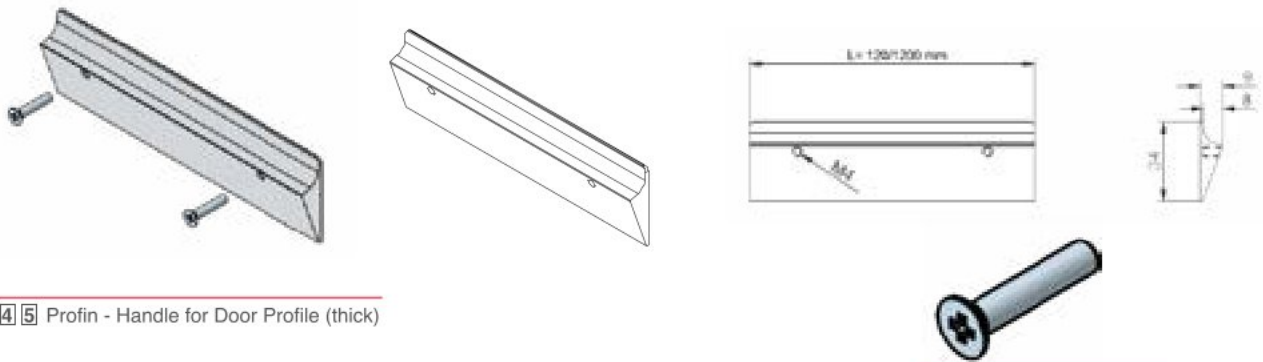

1 2 3 4 5 Profin - Handle for Door Profile (thick)

6 7 Handle Screw

ORDERING INFORMATION

Product Description		Article No.
1	Profin - Handle for Door Profile (thick), Finish: Dark Bronze, Length: 120 mm	563.97.121
	Profin - Handle for Door Profile (thick), Finish: Dark Bronze, Length: 1200 mm	563.97.131
2	Profin - Handle for Door Profile (thick), Finish: Silver, Length: 120 mm	563.97.921
	Profin - Handle for Door Profile (thick), Finish: Silver, Length: 1200 mm	563.97.931
3	Profin - Handle for Door Profile (thick), Finish: Graphite, Length: 120 mm	563.97.321
	Profin - Handle for Door Profile (thick), Finish: Graphite, Length: 1200 mm	563.97.331
4	Profin - Handle for Door Profile (thick), Finish: Gold, Length: 120 mm	563.97.521
	Profin - Handle for Door Profile (thick), Finish: Gold, Length: 1200 mm	563.97.531
5	Profin - Handle for Door Profile (thick), Finish: Rose Gold, Length: 120 mm	563.97.421
	Profin - Handle for Door Profile (thick), Finish: Rose Gold, Length: 1200 mm	563.97.431
6	Profin - Handle Screw, Finish: Zinc Plated	563.97.995
7	Profin - Handle Screw, Finish: Darkened	563.97.996

Unit: Piece

Profin - 45° Corner Connectors & Screw

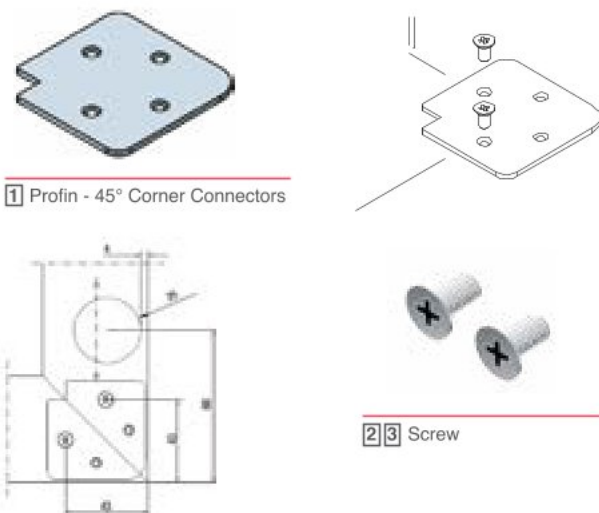

1 Profin - 45° Corner Connectors

2 3 Screw

Profin - 90° Connection Screw

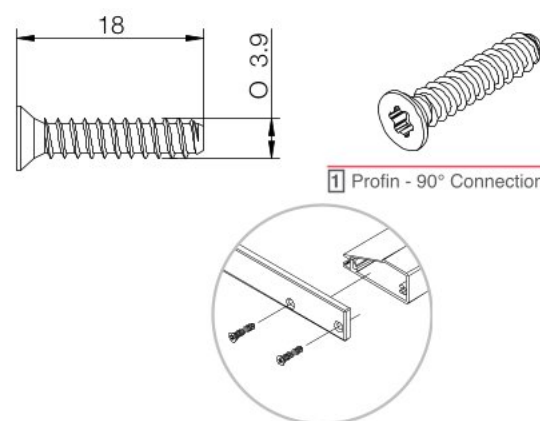

1 Profin - 90° Connection Screw

ORDERING INFORMATION

Product Description		Article No.
1	Profin - 45° Corner Connectors, Finish: Zinc Plated, (Req.: 4 Per Door)	563.97.997
2	Profin - Screw, Zinc Plated, (Req.:16 Per Door)	563.97.993
3	Profin - Screw, Darkened, (Req.:16 Per Door)	563.97.994

Unit: Piece

Note: Use a T15 Standard Torx Screwdriver with this screw

ORDERING INFORMATION

Product Description		Article No.
1	Profin - 90° Connecting Screw, (Req.: 8 Pcs Per Door), Finish: Zinc Plated	563.97.991
2	Profin - 90° Connecting Screw, (Req.: 8 Pcs Per Door), Finish: Darkened	563.97.992

Unit: Piece

INSTALLATION

For 90° Connection

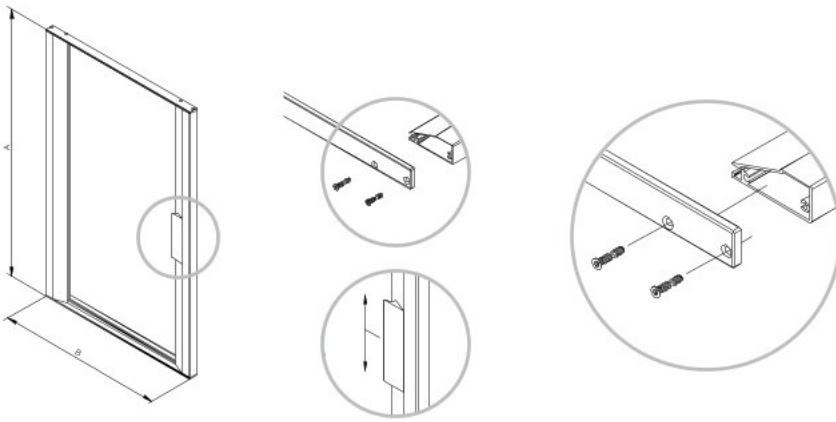

1. Cut the thick door profile to desired length
Length of the thick profile : Door length – 10mm
2. Insert a 4 mm glass panel into the profile
3. Using the 90° connection screws, fix the thin door profile to the thick door profile
4. Fix the handle

For 45° Connection

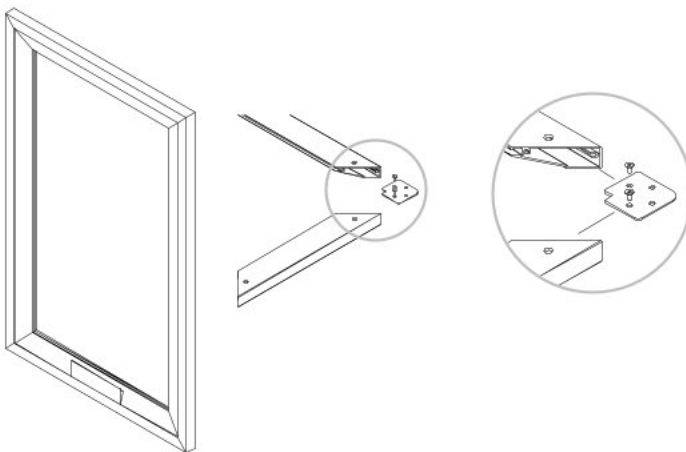

1. Mitre the thick door profiles and cut them to the desired length
2. Insert the 45° connector and using the screws build the frame on three sides
3. Slide in a 4 mm glass panel into the profile frame
4. Enclose the glass by adding in the profile on the fourth side and fixing it in place with the connector and screws
5. Fix the handle

GLASS SIZE CALCULATION

For 90° Connection

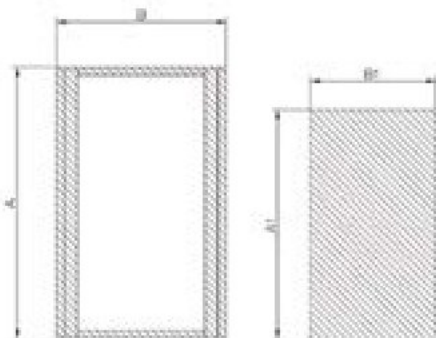

- A1 : A-13
- B1 : B-102

For 45° Connection

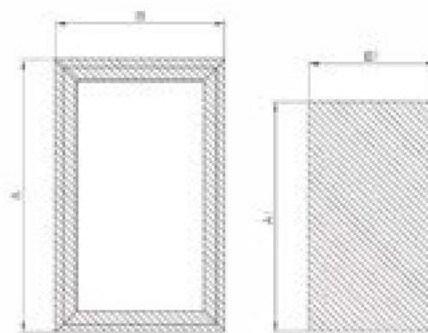

- A1 : A-102
- B1 : B-102

Profin - Strike Shelving System

Decorative Shelves

What's on the inside is as important as what lies on the outside. Häfele introduces its Profin Range of Strike Aluminium Profiles for shelves inside cabinets and tall units. These profiles are a brilliant way to complete the look of your interiors and add ambience, functionality and style to your furniture. The front profile, designed with modularity in concept, includes a groove to include LED strip lights which help illuminate the insides of the cabinet with indicative and directional lighting. These lights can be combined with drivers and sensors so that every time the shutter opens, the lights inside switches on.



Silver



Graphite



Gold



Rose Gold



Dark Bronze

COMPONENTS

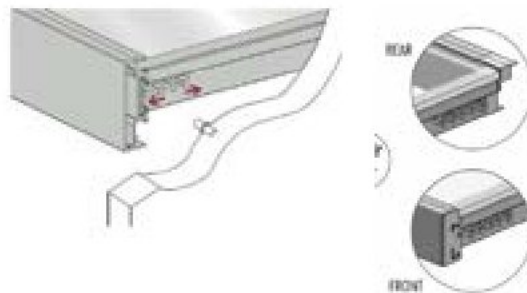
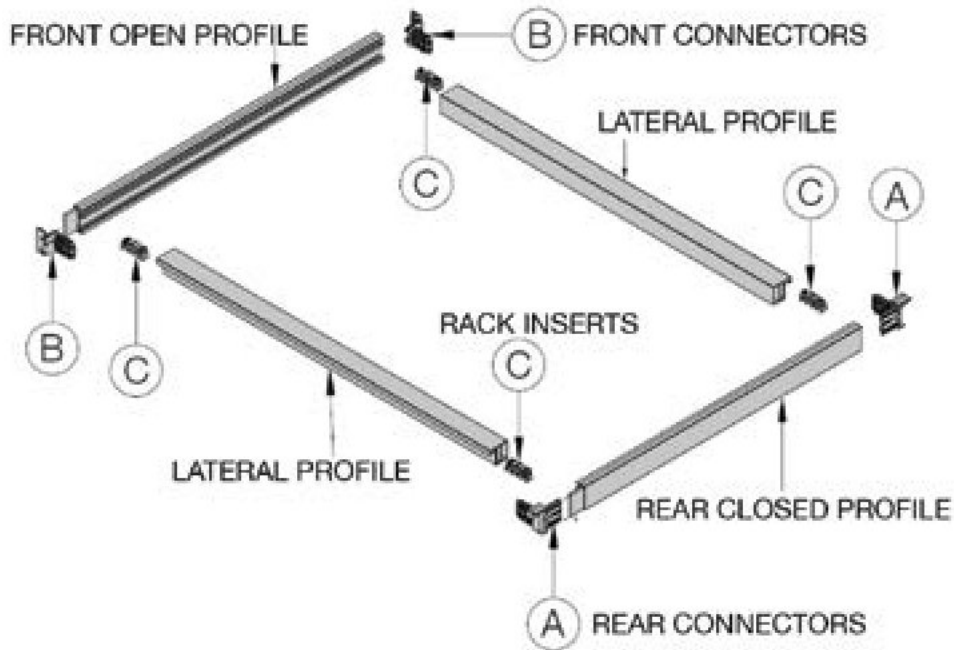

Note: The Rack Inserts placed in lateral profiles interlock with the shelf supports and allow a quick and easy assembly regardless to the position of the shelf supports on the cabinet.

KIT 1

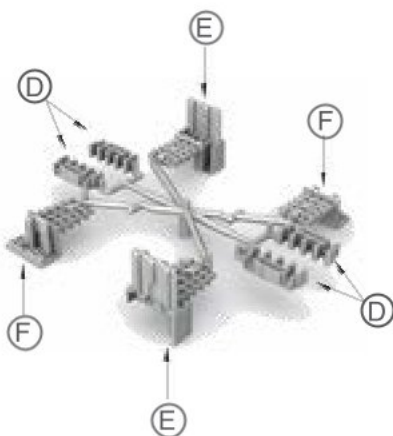

KIT 1: You should order KIT 1 when you use the Front Open Profile together with the Rear Closed Profile. The KIT 1 consists of:

- D. Rack Inserts (4)
- E. Rear Connectors (2)
- F. Front Connectors (2)

KIT 2

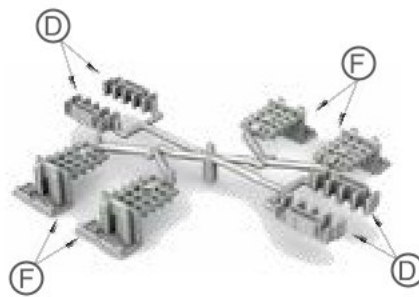

KIT 2: You should order KIT 2 when you use the Front Open Profile in the front as well as at the back (instead of a Rear Closed Profile). The KIT 2 consists of:

- D. Rack Inserts (4)
- F. Front Connectors (4)

APPLICATION

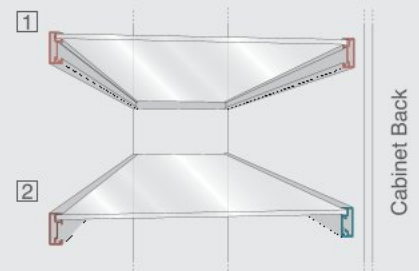

1 Strike shelf with Front Open Profiles in the front and at the back. For this application, KIT 2 needs to be ordered

2 Strike shelf with Front Open Profile in the front and Rear Closed Profile at the back. For this application, KIT 1 needs to be ordered

Note: We recommend using the Front Open Profile with the Rear Closed Profile for a clean aesthetic look.

Profin - Strike Shelving System

Profin - Front Open Profile

For glass thickness: 4mm

Application

- With or without LED strip lights (LED Strip Lights to be ordered separately)
- Can be used in the front as well as at the back

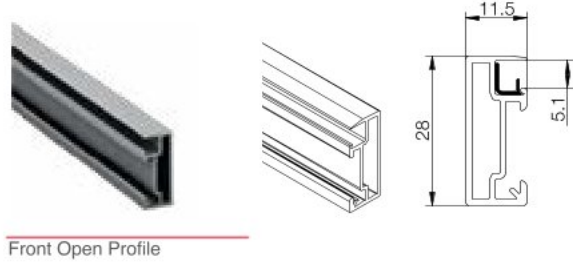

Front Open Profile

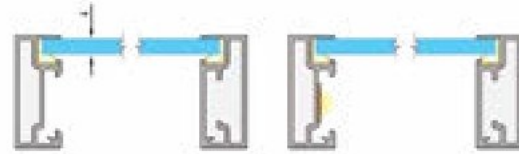

ORDERING INFORMATION

Product Description	Article No.
1 Profin - Front Open Profile, Finish: Dark Bronze, Length: 2050 mm	126.36.201
2 Profin - Front Open Profile, Finish: Silver, Length: 2050 mm	126.36.200
3 Profin - Front Open Profile, Finish: Graphite, Length: 2050 mm	126.36.204
4 Profin - Front Open Profile, Finish: Gold, Length: 2050 mm	126.36.202
5 Profin - Front Open Profile, Rose Gold, Length: 2050 mm	126.36.203

Unit: Piece

Profin - Rear Closed Profile

For glass thickness: 4mm

Application

Can be used only at the back

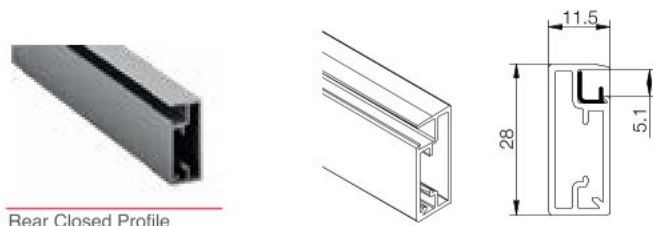

Rear Closed Profile

ORDERING INFORMATION

Product Description	Article No.
1 Profin - Rear Closed Profile, Finish: Dark Bronze, Length: 2050 mm	126.36.206
2 Profin - Rear Closed Profile, Finish: Silver, Length: 2050 mm	126.36.205
3 Profin - Rear Closed Profile, Finish: Graphite, Length: 2050 mm	126.36.209
4 Profin - Rear Closed Profile, Finish: Gold, Length: 2050 mm	126.36.207
5 Profin - Rear Closed Profile, Finish: Rose Gold, Length: 2050 mm	126.36.208

Unit: Piece

Profin - Lateral Profile

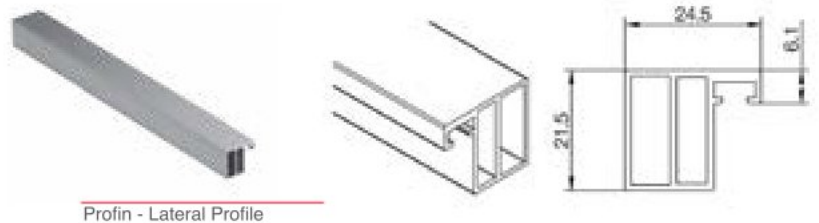

Profin - Lateral Profile

ORDERING INFORMATION

Product Description	Article No.
1 Profin - Lateral Profile, Finish: Dark Bronze, Length: 2050 mm	126.36.211
2 Profin - Lateral Profile, Finish: Silver, Length: 2050 mm	126.36.210
3 Profin - Lateral Profile, Finish: Graphite, Length: 2050 mm	126.36.214
4 Profin - Lateral Profile, Finish: Gold, Length: 2050 mm	126.36.212
5 Profin - Lateral Profile, Finish: Rose Gold, Length: 2050 mm	126.36.213

Unit: Piece

Accessories

Profin - Rack Inserts, Front Connectors & Rear Connectors

KIT 1

Application: Strike shelf with Front Open Profile in the front and Rear Closed Profile at the back

Consists of:

- 2 × Rack Inserts
- 2 × Front Connectors
- 2 × Rear Connectors

KIT 2

Application: Strike shelf with Front Open Profiles in the front and at the back

Consists of:

- 2 × Rack Inserts
- 4 × Front Connectors

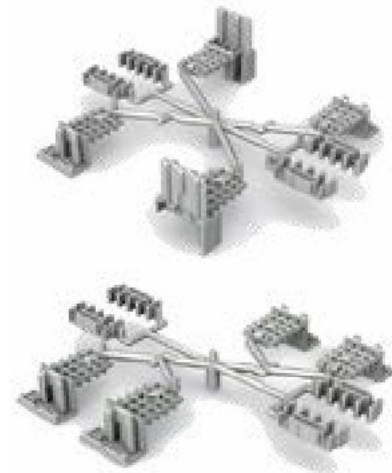

ORDERING INFORMATION

Product Description	Article No.
1 KIT 1, Finish: Grey, Strike Connector Set for Rear Closed Profile	126.36.216
2 KIT 2, Finish: Grey, Strike Connector Set for Rear Open Profile	126.36.215

Unit: Kit

Profin - Shelf Support Kit



Profin - Shelf Support Kit

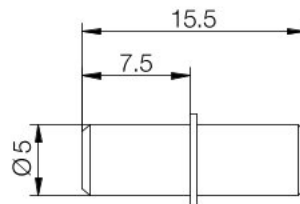

ORDERING INFORMATION

Product Description	Article No.
1 Profin - Shelf Support Kit, Finish: Nickel Plated	282.43.750

WEIGHT CARRYING CAPACITY DETAILS



Note:

- The weight carrying capacity is for reference purposes only and is limited to a shelf depth of 500 mm only
- The weight capacity includes the weight of the hardware as well as the weight of the shelf

Calculations

For cutting the Strike profiles

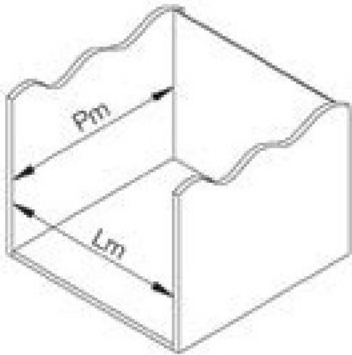

- Front Open Profile = Internal Cabinet Width (L_m) - 2 mm
- Closed Rear Profile = Internal Cabinet Width (L_m) - 50 mm
- Lateral Profile = Internal Cabinet Depth (P_m) - 26 mm

For glass dimensions



- Glass Width = Total Width of Shelf (L_s) - 2 mm
- Glass Depth = Total Depth of Shelf (P_s) - 13 mm

LED Strip Lights Configuration

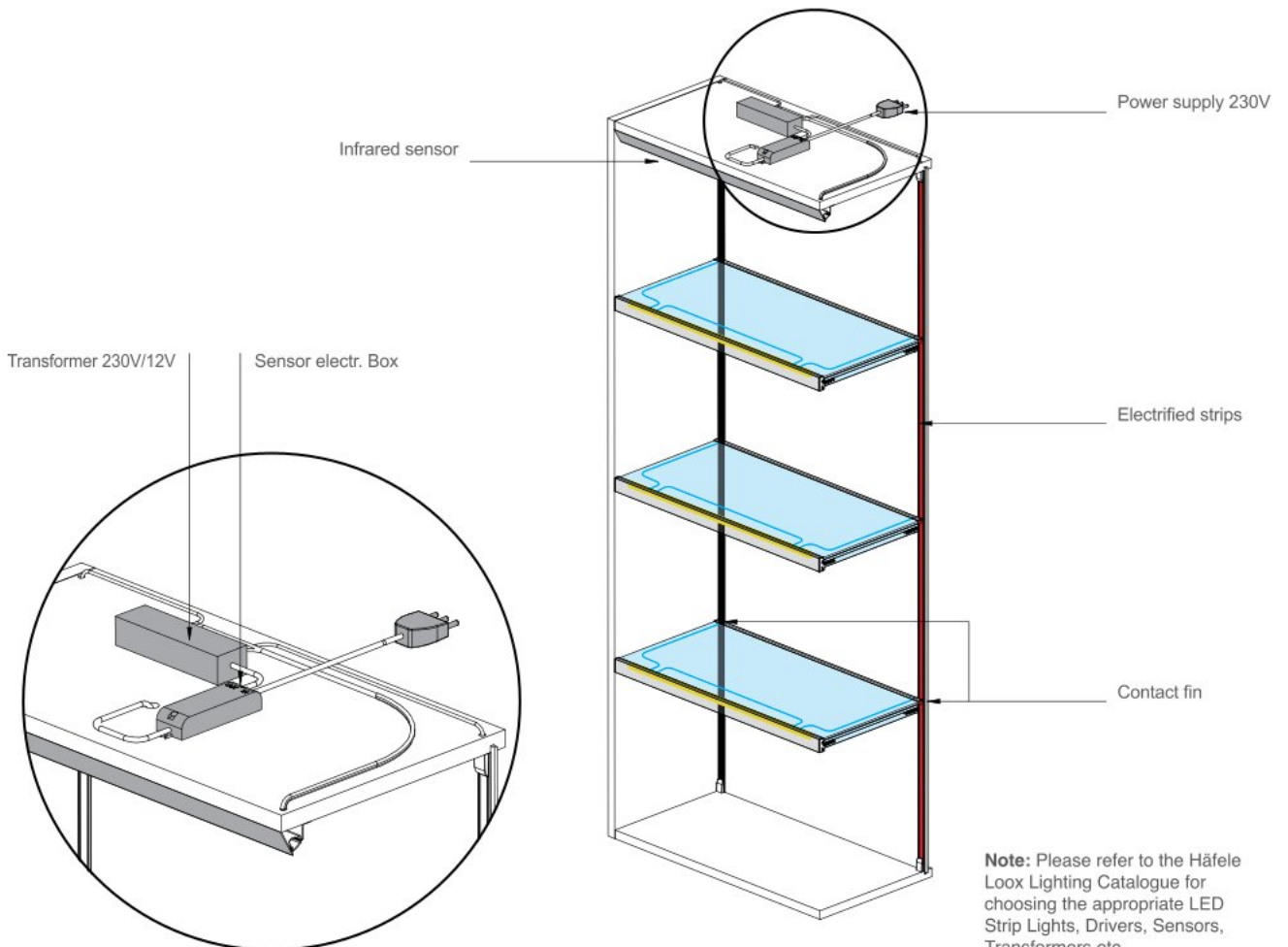

Aluminium Profiles for Frameless Glass Kitchen Shutters



- The design is attractive and easily blends with rest of the kitchen furnishing.
- Available in two trendy and contemporary finishes of silver anodized aluminum & matt black epoxy coated aluminum.
- This innovative hassle free system can be used in kitchens with 4 mm glass paneling.
- The aluminum profiles are connected by strong steel connectors which ensure sturdy joint connections, ideal for long-term use.
- These profiles are very easy to install and enhance the aesthetics of the kitchen.



Alu Facade Aluminium Frame Profile

- 1 Silver Anodized
- 3 Black Epoxy



Alu Facade Aluminium Frame Profile with Handle

- 2 Silver Anodized
- 4 Black Epoxy

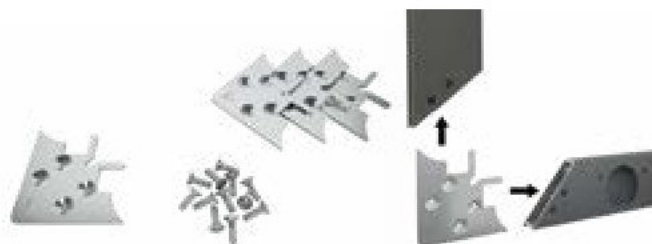

5 Corner Connector

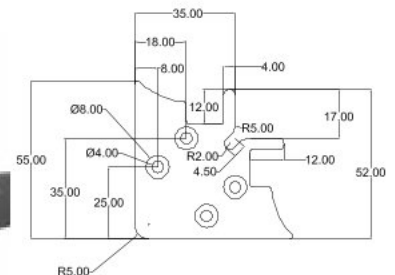

ORDERING INFORMATION

Product Description	Article No.
1 Aluminium frame profile, Finish: Silver anodized, Length: 3000 mm	563.95.905
2 Aluminium frame profile with handle, Finish: Silver anodized, Length: 3000 mm	563.95.915
3 Aluminium frame profile, Finish: Black Epoxy, Length: 3000 mm	563.95.303
4 Aluminium frame profile with handle, Finish: Black Epoxy, Length: 3000 mm	563.95.312
5 Corner connector for 45mm wide frameless aluminum profile compatible for hinge & mounting plate drilling (4 corner connectors & 16 m4x10mm machine thread screws), Finish: Zinc Galvanised, Length: 55 x 55 x 2.5 mm	563.47.991

(Same connectors to be ordered separately for all profiles)

Note: 3M VHB Tape - 30mm / 3M Tape primer 94 to be sourced by the customers.

ProDoor







In the world of design, trends change and evolve continuously with new innovation and technology. Keeping up with them and bringing to you the latest, technologically advanced and price-competent solutions for your home interiors is what we at Häfele strive to achieve. Kitchen as an area of the house, especially with many now opting for contemporary layouts that foster openness and community building activities among family members, often attracts the potential for constant innovation through the ever-evolving usage patterns and the ever-changing definitions of functionality and ergonomics.

Häfele introduces a new collection – ProDoor under its Aluminium Profiles Range that will enable you to visualise your furniture as a canvas and will let you play around with fittings, bringing to you the possibility of achieving trends such as handle-less doors, adaptive colour schemes, vintage-inspired contemporary designs and clean door designs with no visible hardware.

Häfele's ProDoor Range attempts to provide you with an array of profile systems for constructing cabinet doors that flawlessly complement the overall design aesthetics of not only the kitchen but also other living spaces of your home and have the potential of upgrading them to their most contemporary version yet. The range comprises of Match Door, Plusch Door, Klar Door and Wardrobe Rail. These door systems are available in two classic finishes, Brushed Stainless Steel for silent sophistication and Brushed Black for a hint of dramatic flair.

MATCH DOOR



For an overall clean and immaculate kitchen appearance, people are increasingly opting for handle-less kitchens. Handle-less solutions ensure that the kitchen interiors are completely clear with seamless visuals of cabinet and drawer fronts. Match Door Profiles transform this vision beautifully into a reality.

Fundamental in style and providing you with the option of customisation, these profiles offer you the freedom of working with the colour and tonality of your kitchen, creating it as per your imagination.

Handle-less and minimalistic appearance:

Match Door Profiles provide a modern handle-less look to your kitchen space. They are functionally useful in the form of handles as well as aesthetically pleasing when seen as part of the kitchen layout.

Can be matched to the décor:

With Match Door Profiles, you have an option of customising your door design by pasting an edge band in the slot provided. Whether you want to match the profile to your doors for a unified look or make the profile lining pop out in the kitchen layout, the possibilities are endless.

Ventilation for hobs:

The Match door profile installed onto the top drawer can be perforated to provide efficient ventilation for built-in hobs.

Application

• With Edge Banding



If your kitchen design demands a play on colour, you can easily extend the colour theme onto your Match Door Profiles that give you an option of pasting an edge-banding of any colour you desire onto the profile, thereby helping you achieve synergy in the overall aesthetics.

• Without Edge Banding



The Match Door Profiles inherently come in trendy finishes, Brushed Stainless Steel and Brushed Black. If you love minimalist design and colour schemes, you can use the profiles as is without adding that extra element of edge banding. The slightly lustrous finish of the profiles makes for an interesting addition in kitchens with traditional colour patterns.

Trends Match Door contributes to:

➤ Handle-less Appearance

Handle-less kitchens have gained tremendous popularity in the recent years owing to the clean and sophisticated look they provide to your kitchen. Made possible through solutions like push-to-open (automatic-opening mechanisms and profiles for cabinet doors, handle-less kitchens not only promote convenience but also create a view of streamlined flow in kitchen units resulting in a chic and clutter free look.

➤ Customisation in Colour Schemes

The kitchen is one of the places in the home where one spends a lot of time. It is therefore essential that it should look and feel comfortable, inviting, and most importantly 'you'. With customisations of key kitchen fittings, you can create your own colour scheme – whether monochromatic, where everything blends together or dual and multi-tone, where numerous colours are at play. You can also introduce colour pops that help break the monotony of a set coloured pattern and lay emphasis on a few furniture elements that need highlighting.

Assembly

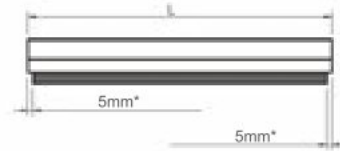
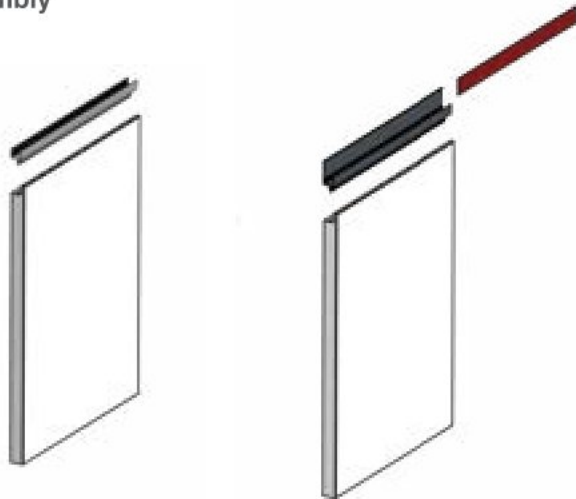

- Match Door Profile - Short
- Match Door Profile - Tall
- Edge Band

L: The length of the profile should be equal to the width of the panel
 Edge banding thickness: Up to 1 mm

* The part of the profile that fits into the groove of the panel needs to be shortened by 5 mm from both sides

Match Door - Tall



1 Brushed Stainless Steel



2 Brushed Black

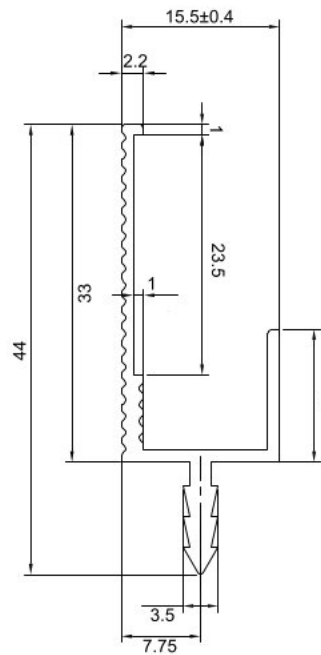

Match Door - Short



1 Brushed Stainless Steel



2 Brushed Black

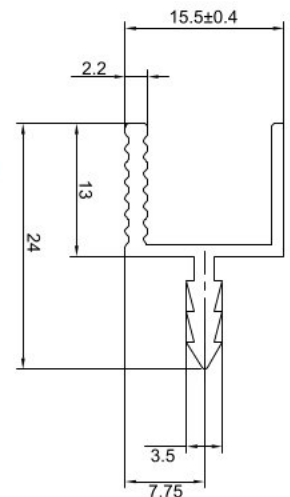

ORDERING INFORMATION

Product Description	Finish	Material	Length (mm)	Min. Door Thickness (mm)	Article No.
Match Door - Tall	Brushed Stainless Steel	Aluminium	3000	18	563.93.863
	Brushed Black				563.93.363

Customisation Option with Edge Band Available: Yes

Edge Band Dimensions: Height: 22 mm, Thickness: Up to 1 mm

Application: Cabinets, top and bottom drawers in two/ three drawer configurations

Product Description	Finish	Material	Length (mm)	Min. Door Thickness (mm)	Article No.
Match Door - Short	Brushed Stainless Steel	Aluminium	3000	18	563.93.873
	Brushed Black				563.93.073

Customisation Option with Edge Band Available: No

Application: Middle drawers in three drawer configurations

Installation

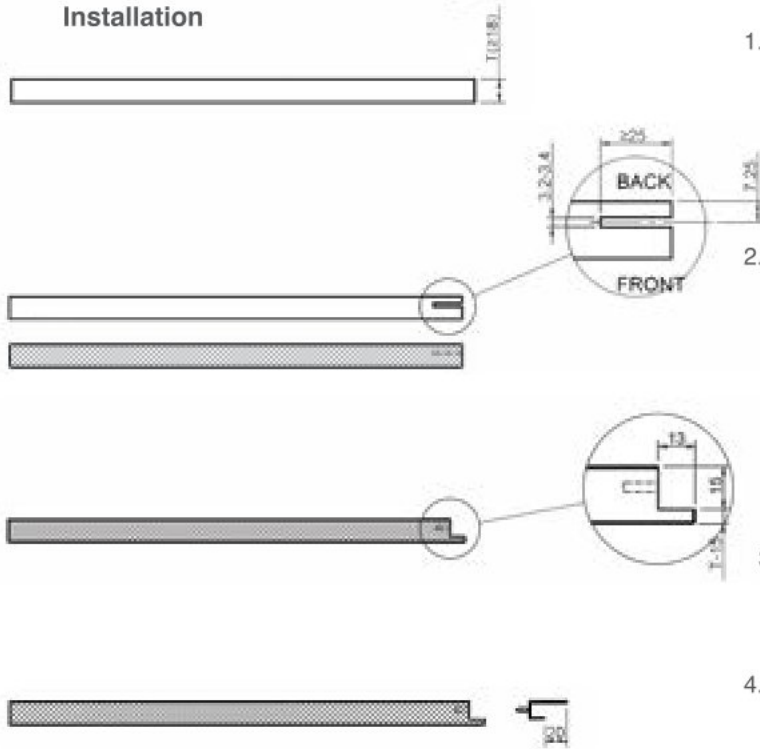

1. Cut the panel for the drawer front or cabinet door according to the size required and cut the profile equal to the width of the panel.

2. Make a groove in the panel for the profile to be inserted and stick edge banding along all the edges (thicknesses) of the wooden panel

3. Route out the space for positioning the handle

4. Apply silicon glue and press the match handle profile into position. You can paste edge band on the profile if needed.

Tips to achieve better aesthetics



Fig. a: Two drawer configuration

1. For a two drawer configuration, the tall version of match door profile is used for both the top and bottom drawers.



Fig. b: Three drawer configuration

2. For a three drawer configuration, there are two possibilities of installation:

- tall-tall-tall - for a spacious look
- tall-short-tall - The short profile can be installed below the second drawer for a minimum gap between the top two drawers and low profile visibility (refer fig. b)

PLUSCH DOOR



Plusch Door from the ProDoor Range goes one step beyond your conventional profiles. Multiple design schemes depending on the vision you are going for are now possible! With Plusch Door Profiles, you can experiment with different materials for the cabinet doors and drawer fronts like veneer, glass, metal sheets and ultra-compact stone surfaces like Dekton to create visually stunning interiors while keeping the door weight light. All the hardware and screws are hidden conveniently behind the decor material from the front while a thin back panel slid into the frame from the inside seals the hollow cavity created by the profiles, leaving you with flawless-looking furniture doors. The back panel colour can be matched to the cabinet interiors in order to create seamless aesthetics.

Lightweight shutters:

The Plusch Door Profiles when joined together form a hollow frame for the cabinet door. The decorative material is stuck onto the exterior frame side while a thin 2 mm back panel is slid into the frame interior. Even heavy materials like stone can be used in the form of thin sheets as the décor material. This construction makes the cabinet doors extremely lightweight, enhancing overall ease.

Decorative materials for doors:

As Plusch Door Profiles form the basic frame structure for the cabinet front, you have complete freedom in experimenting with the material of the door in addition to the more traditionally used wood and glass. Decorative materials like veneer, stone, metal sheets can be stuck on to the frame to create stunning design concepts in your kitchen.

Customisable 2 mm back panel:

Plusch Door Profiles come with a provision to slide in a 2 mm back panel to fill up the hollow cavity inside. This makes the structure of the shutter look wholesome and stable while maintaining its light weight. This panel can be matched to the colour of your cabinet interiors.

No visible joinery:

The connectors used for joining the Plusch Door Profiles are fixed with screws from the front (outward facing portion) of the profile, which is then covered by the decorative door material. There is hence no hardware visible from any side of the assembled cabinet door providing a clean and immaculate appearance.

Application

• Handle and Main Profiles for Framed Doors



Plusch Door Handle and Main Profiles are the primary shutter construction units. The handle profile on one side and three main profiles on the other, form a frame on to which the decorative door material is stuck. Plusch profile can also be used for sliding doors applications.

• Wooden Door Profiles



The Plusch Door range has two profiles for wooden doors, Wooden Door Lip Profile and Handle Profile. The lip profile is a simple profile that can be fixed on wooden doors to match the profile theme used for other cabinets and the handle profile can work as an individual handle for any drawer front or cabinet door.

Trends Plusch Door contributes to:

➤ Exploring New Design Possibilities with Different Materials

Gone are the days, when your furniture doors were formed entirely of wood, ply and laminates. With the aim of bringing about a change in the aesthetics of the kitchen and to explore new design possibilities, we now have kitchen furniture exhibiting stone surfaces, glass exteriors, metal sheets and veneer. This opens up a whole new world of materials for us to experiment with while attaining the same or improved level of functionality.

Assembly

Plusch Door Main and Handle Profiles

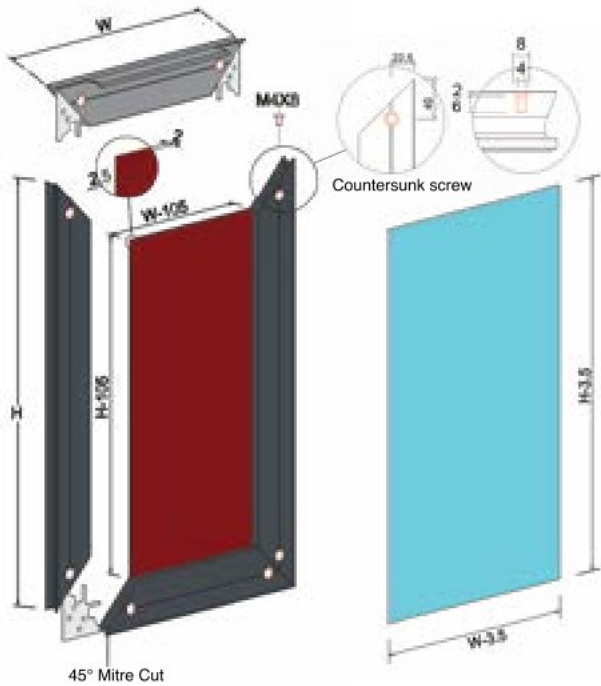

- Plusch Door Handle Profile
- Plusch Door Main Profile
- Kite connector
- 2 mm back panel (inserted into the groove in the back of the frame)
- Countersunk screw
- 3-6 mm decorative material (pasted on the front of the frame, visible from outside)

W: Width of the door
 H: Height of the door
 Width of the decorative material: W-3.5
 Height of the decorative material: H-3.5

Note: The screw holes are to be made on the face of the profile (which is then covered by the door material that gets stuck onto it) instead of at the back like in case of regular profiles

Plusch Wooden Door Lip and Handle Profiles

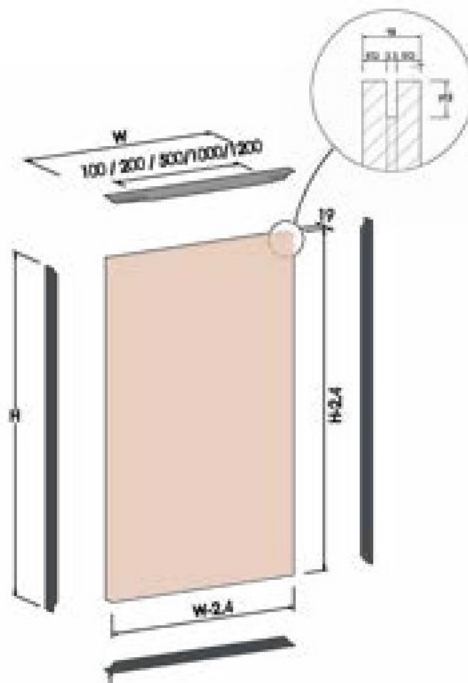

- Plusch Wooden Door Handle Profile
- Plusch Wooden Door Lip Profile
- Wooden panel

W: Profile length along the width of the door
 H: Profile length along the height of the door
 Width of the wooden panel: W-2.4
 Height of the wooden panel: H-2.4

Plusch Door Main Profile



1 Brushed Stainless Steel



2 Brushed Black

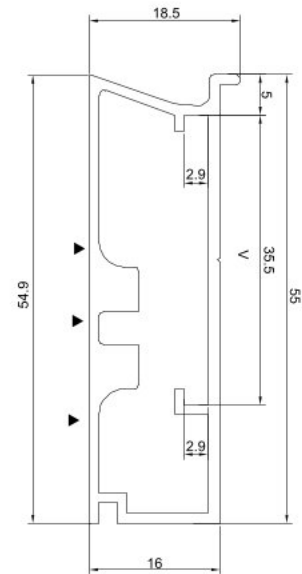

Plusch Door Handle Profile



1 Brushed Stainless Steel



2 Brushed Black

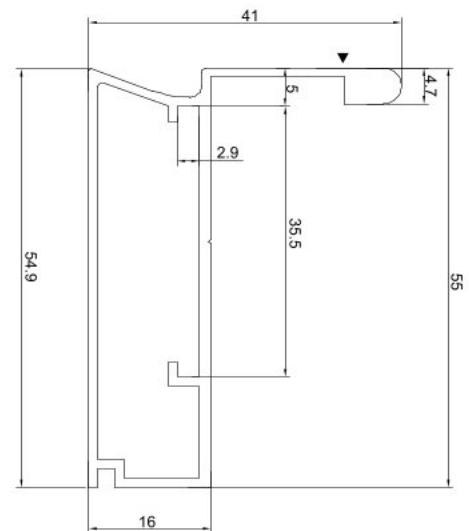

ORDERING INFORMATION

Plusch Door Main Profile

Material	Length (mm)	Weight of the Profile (kg)	Brushed Stainless Steel	Brushed Black
Aluminium	3000	2.27	563.93.003	563.93.303

Decorative Material Thickness: 3 - 6 mm (Up to 4 mm for glass and stone)

Back Panel Thickness: 2 mm (Material Recommended: Aluminium Composite Sheet)

Application: Non handle sides of the shutter frame

Plusch Door Handle Profile

Material	Length (mm)	Handle Length (mm)	Weight of the Profile (kg)	Brushed Stainless Steel	Brushed Black
Aluminium	200	100	0.15	563.94.014	563.94.314
	500	200	0.37	563.94.015	563.94.315
	1000	500	0.74	563.94.011	563.94.311
	1800	1000	1.33	563.94.012	563.94.312
	3200	1200	2.36	563.93.013 (Left)	563.93.313 (Left)
	3200	1200	2.36	563.93.023 (Right)	563.93.323 (Right)

Decorative Material Thickness: 3 - 6 mm (Up to 4 mm for glass and stone)

Back Panel Thickness: 2 mm (Material Recommended: Aluminium Composite Sheet)

Application: Handle side of the door frame

Plusch Wooden Door Lip Profile



1 Brushed Stainless Steel



2 Brushed Black

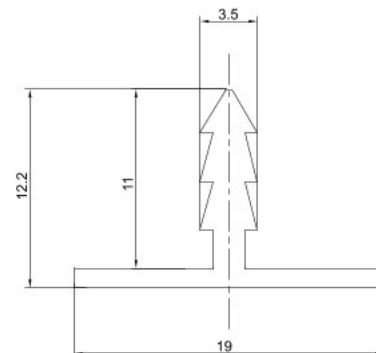

Plusch Wooden Door Handle Profile



1 Brushed Stainless Steel



2 Brushed Black

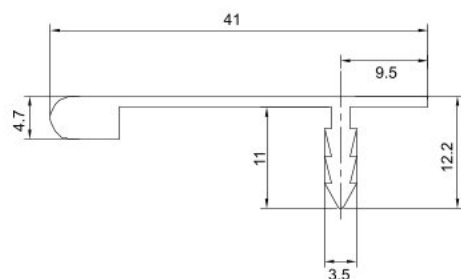

Kite Connectors



ORDERING INFORMATION

Plusch Wooden Door Lip Profile

Material	Length (mm)	Door Thickness (mm)	Brushed Stainless Steel	Brushed Black
Aluminium	3000	18-25	563.93.033	563.93.333

Application: Edges of wooden shutters

Plusch Wooden Door Handle Profile

Material	Length (mm)	Handle Length (mm)	Door Thickness (mm)	Brushed Stainless Steel	Brushed Black
Aluminium	200	100	18 - 25	563.94.044	563.94.344
	500	200		563.94.045	563.94.345
	1000	500		563.94.041	563.94.341
	1800	1000		563.94.042	563.94.342
	3200	1200		563.93.043 (Left)	563.93.343 (Left)
	3200	1200		563.93.053 (Right)	563.93.353 (Right)

Application: Handle side of the wooden shutter

Kite Connectors

Finish	Material	Article No.
Steel	Zinc Plated Steel	564.94.995*

*The kit consists of 4 kite connectors and fixing screws

Technical Specifications

The length of the handle in the Plusch Door and Plusch Wooden Handle Profiles are shown below. For profile of lengths 200 mm, 500 mm, 1000 mm and 1800 mm, the handle is positioned at the centre of the profile; for

profilelengths of 3200 mm, the handle is positioned at the ends of the profile. The 3200 mm handle profiles come in a left and right version, ideal for use on tall cabinet and wardrobe doors.

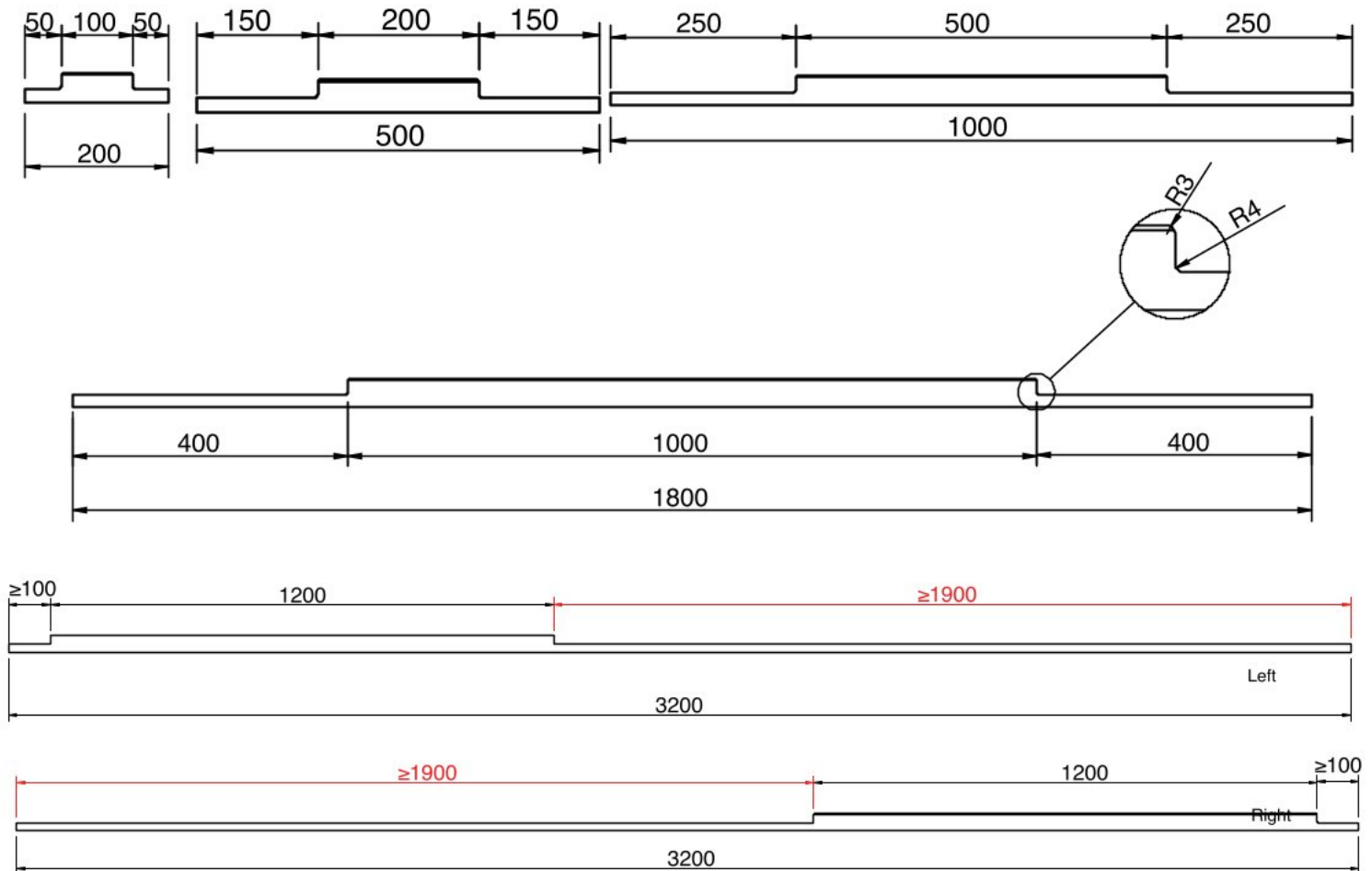

Installation

Plusch Door Main and Handle Profiles

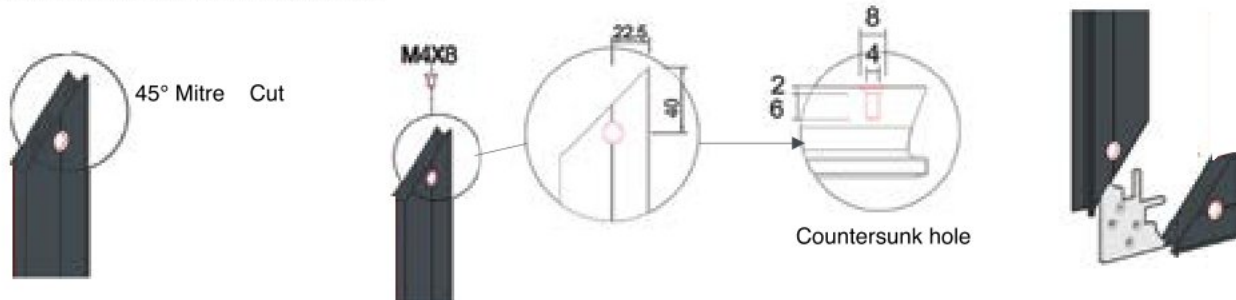

1. Mitre cut the Plusch Door profiles according to the desired length of the door frame. Remember that the handle profiles will be cut from both ends equally.

2. Make the drilling holes for screws using the guiding line on the profile as per the dimensions above. Screw holes should be made in the front of the profiles instead of back like in case of regular profiles.

3. Insert the kite connector and join two profiles to create one corner of the frame structure.

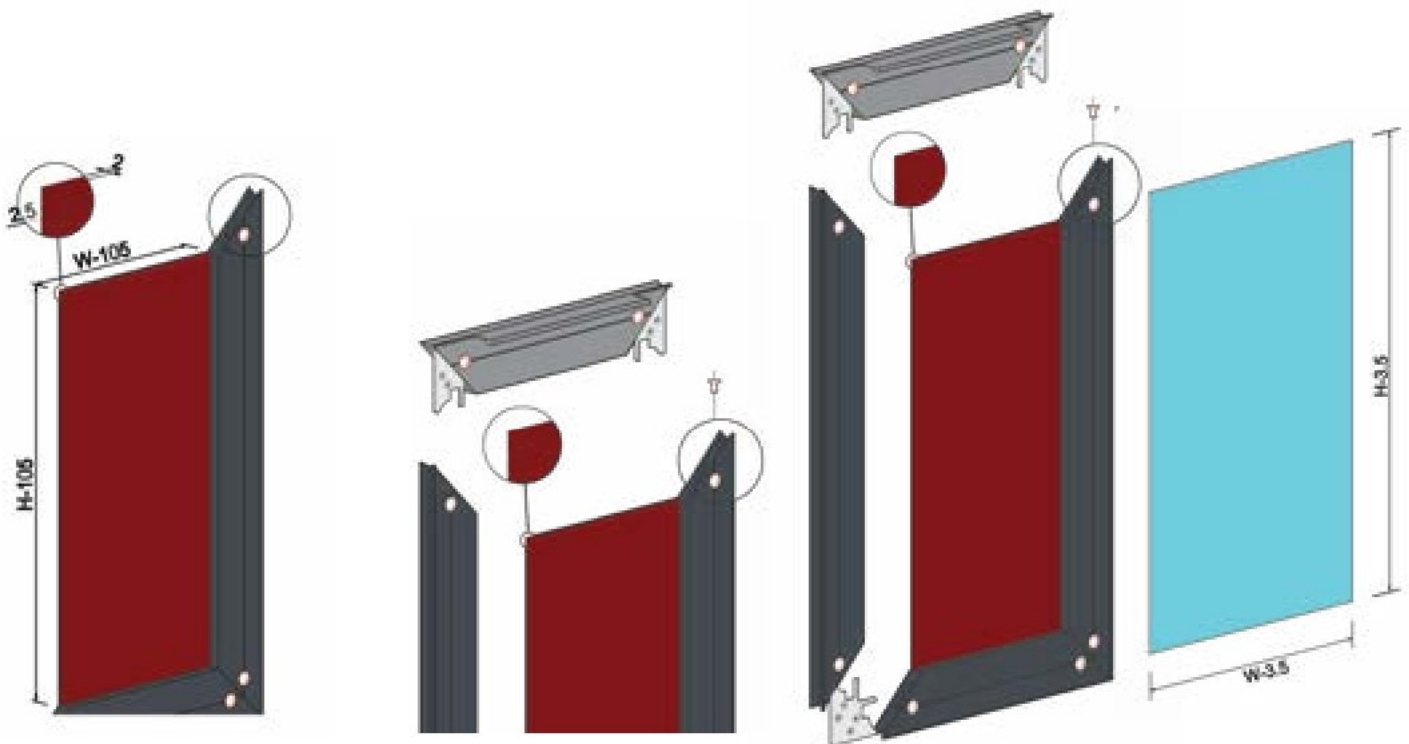

4. Insert a 2 mm back panel into the partial frame (dimensions as shown above where W = width of the door, H = height of the door) in order to cover the hollow part in the profile door.

5. Using the kite connector, join the other profiles and lastly insert the handle profile. The structure is completely ready now.

6. Paste decorative material like Veener, glass, metal sheets or Dekton to complete the shutter. Dry fixing can be done using 3M VHB tape (the tape is placed along the centre of the profiles) and we fixing can be done using DOW 795 sealant (the sealant is applied along the edges of the profiles)

Plusch Wooden Door Lip and Handle Profiles

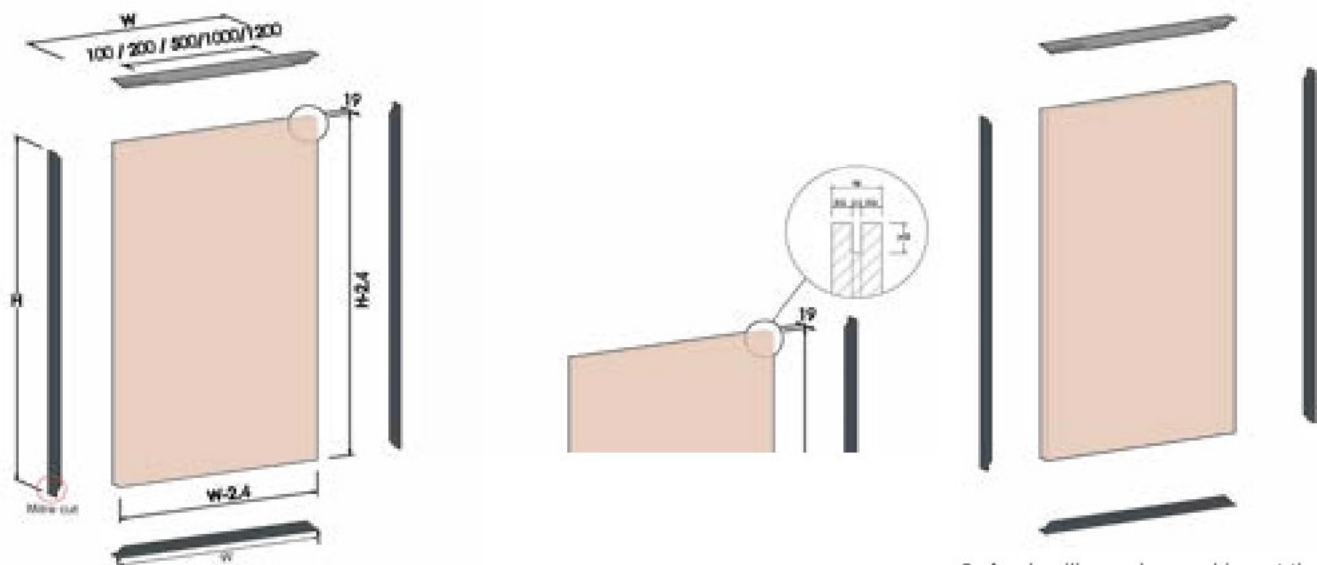

1. Prepare the Plusch Door profiles and wooden panel for shutter according to the dimensions shown above. Remember the handle profiles will be cut from both ends equally. After cutting the profiles, mitre cut only the portion of the profile that fits into the groove.

2. Make the grooves in the wooden panel on all the sides. The panel thickness can differ from the one shown here (19 mm). In that case, note that the groove needs to be made exactly in the centre of the panel thickness.

3. Apply silicon glue and insert the profiles inside the grooves of the panel.

KLAR DOOR

Häfele has the right product for every area of your home. Klar Door creates smart and elegant looking cabinet systems and can be used in multiple areas of your home. Perfect for wall units, wardrobes, bar cabinets, etc., the unique structure of the profile helps create vintage-inspired contemporary designs with the handle running along all sides. It is a versatile profile that not only is apt for your kitchens but also seamlessly extends the kitchen design to adjoining multipurpose living spaces. Klar Door can also be clubbed with Häfele's Wardrobe Accessories to create sophisticated wardrobes or storage solutions.

Complementing the Klar Door are Klar door hinges especially designed for their slim form. This hinge enables soft closing of the door for silent operation.

Profile with built-in handle:

The Klar Door Profile comes with a built-in handle which runs on all four sides of the door thus providing uniformity in design. Since the handle is a part of the profile, the ordering process becomes easier.

Invisible hinges:

Klar Door Profile is compatible with Klar Door hinges that are specially designed to be installed into the thickness of the profile and the cabinet thus making them completely invisible when the door is closed. These hinges are compatible with wooden doors as well.

Soft-closing mechanism:

The Klar Door Hinge is equipped with a soft closing mechanism ensuring silent closing of cabinet doors making way for peaceful operation.

Trends Klar door contributes to

➤ Minimalist Build

Functionality achieved with things you can't see is magic. The popular 'invisible/ no hardware' trend essentially means that the hardware used is hidden from your eyes and tucked away inside the material of the furniture. The result is minimalist and sophisticated aesthetics.

➤ Vintage-inspired Contemporary Design

As we are evolving and moving towards new designs, it is also interesting to look back and adopt some classic layouts. A niche area for people who want the best of both worlds - functional contemporary with artistic and distinctive vintage designs, this combination provides a unique look for modern homes.



Application



● Klar Door - Glass

Profiled glass doors created using Klar Door Profiles provide an air of sophistication to your kitchens. The protrusion in the structure of this profile is uniform on all four sides, serving as a handle and also a design element for any glass door cabinetry.

● Klar Door - Wood

The Klar Wooden Door Handle from this range is intended for wooden shutters. This comes in handy when you want to maintain a design continuity between your Klar glass door cabinets and your wooden door cabinets.

Assembly

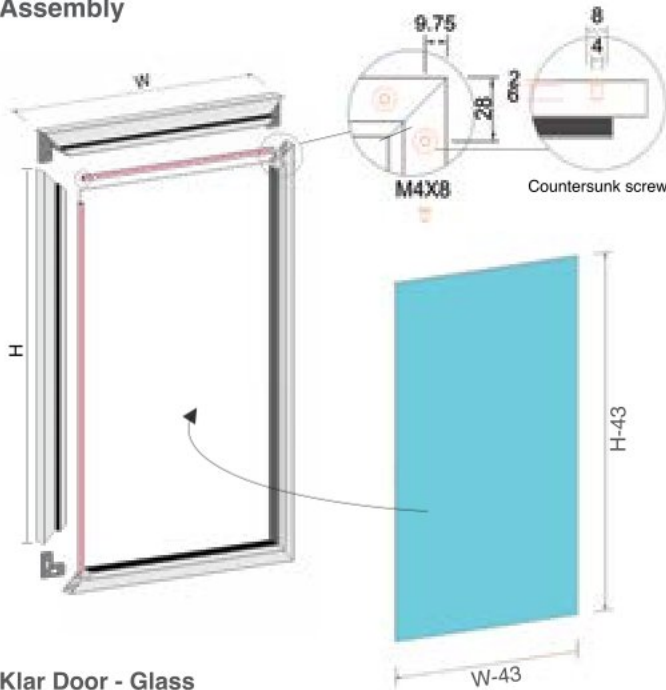

- Klar Door Profile
- 4-5 mm Glass
- C Shaped Gasket
- Corner Connector
- Countersunk Screws

W: Width of the door
 H: Height of the door
 Width of glass panel: W-43
 Height of glass panel: H-43

Note: The overall weight of the shutter (glass and profiles) should not exceed 20 kg

Klar Door - Glass



1 Brushed Stainless Steel



2 Brushed Black

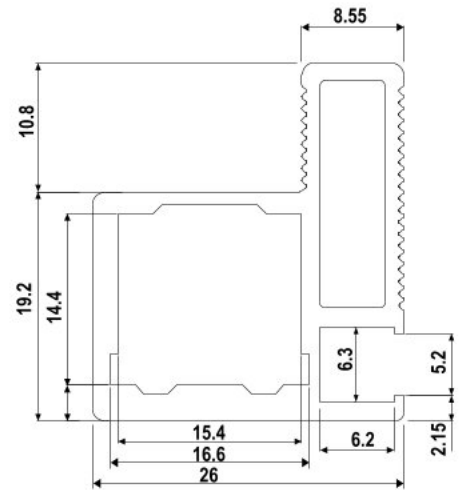

Klar Door - Wood



1 Brushed Stainless Steel



2 Brushed Black

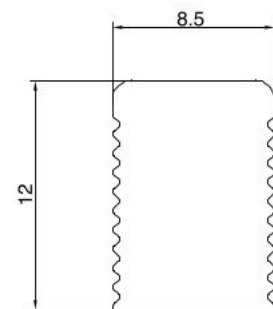

ORDERING INFORMATION

Klar Door - Glass

Material	Length (mm)	Thickness of Profile (mm)	Weight of the Profile (kg)	Glass Thickness (mm)	Brushed Stainless Steel	Brushed Black
Aluminium	3000	19.2	1.82	4-5	563.93.083	563.95.343

Application: Glass cabinet doors

Klar Door - Wood

Material	Length (mm)	Brushed Stainless Steel	Brushed Black
Aluminium	3000	563.93.093	563.93.393

Application: Wooden doors

Note: Predrilled holes are present on the profile along its length, 96 mm apart to make its installation on the wooden doors easy while fixing with screws

Klar Door Hinge



1 Silver



2 Black



Corner Brackets
(342.79.717 - Right
342.79.718 - Left)



Corner Connectors
(564.94.996)

Adjustments

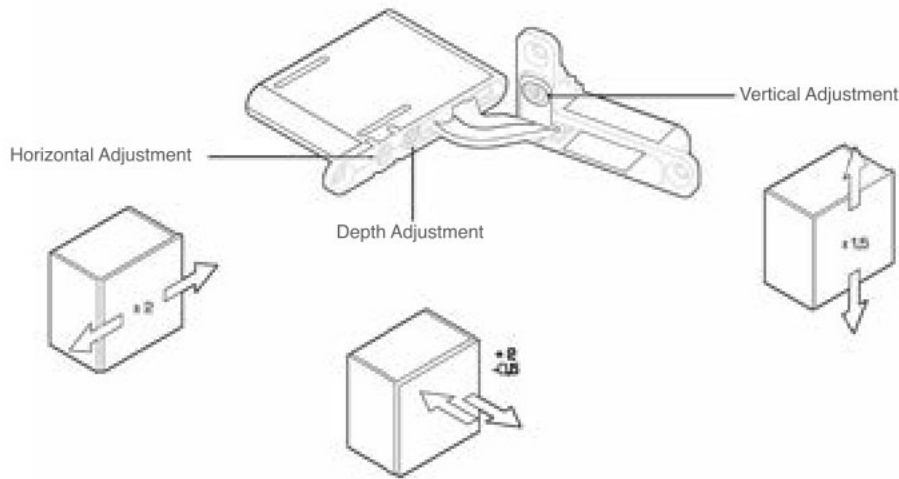

Gasket

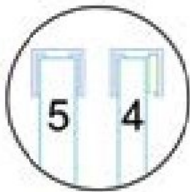

ORDERING INFORMATION

Material	Door Dimensions	Door Weight (kg)	Application	Finish	
Aluminium	Height: Max. 2100 mm, Width: Max. 600 mm, Thickness: 18-32 mm (for Wooden Doors)	Max. 20		Silver	Black
			Profiled Doors	342.79.331 *	342.79.332 *
			Wooden Doors	342.79.700 **	342.79.300 **
Adjustments:		Horizontal, Vertical and Depth			
Opening Angle:		103°			
Integrated Soft Close Mechanism: Available					

* These are BOM kits for profiled doors: consisting of 2 hinges (left + right), 2 corner brackets (left + right) and 2 corner connectors for profiles

** These are BOM kits for wooden doors: consisting of 2 hinges (left + right)

Product Description	Material	Finish	Length (mm)	Article No.
C Shaped Gasket for 5 mm glass	PVC	Black	3000	563.95.391
Filler Gasket for 4 mm glass			1000	563.95.390*

* For 4 mm glass, please use 4 mm Filler Gasket along with 5 mm C Shaped Gasket

Technical Specifications

Door/ Profile drilling dimensions

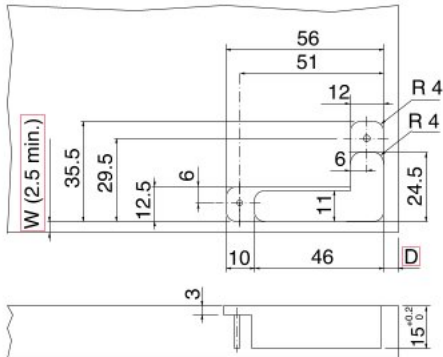

Cabinet top and bottom panel drilling dimensions

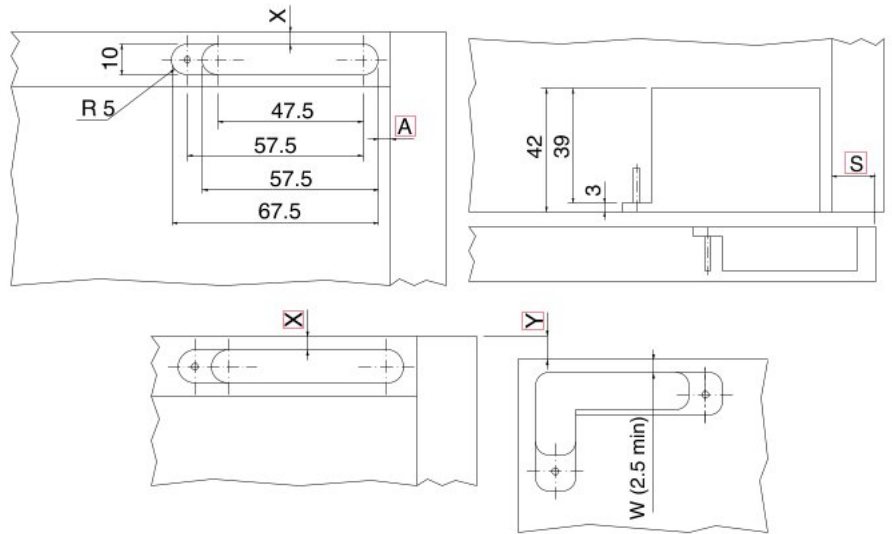

W (Distance from the bottom and top edge of the door to the milled cavity for the corner bracket) = min. 2.5 mm

D (Distance from the hinge-side edge of the door to the milled cavity for the corner bracket) = 3-6 mm

S (overlay of the shutter on the cabinet side thickness) = can be decided by the cabinet constructor as per use, need and application

Y (Visible thickness of the cabinet top panel when shutter is closed) = Can be determined as per application

A (Distance from the inside edge of the cabinet side panel to the drilled cavity for the hinge body) = $(17 + D) - S$

X (Distance from the cabinet top panel edge) = $W + Y$ (Thickness of the door) = 18-32 mm

D (Distance from the hinge-side edge of the door to the milled cavity for the corner bracket) = 3-6 mm

Space required for door's opening

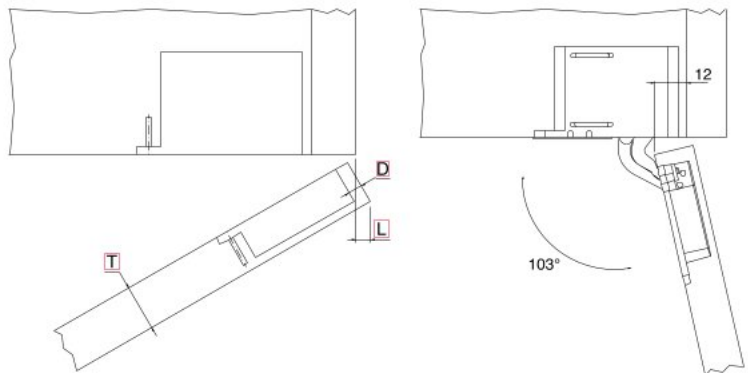

Space required for the opening of the door (mm)	T = 18	T = 20	T = 22	T = 24	T = 26	T = 28	T = 30	T = 32
L (D = 3)	-	0.2	0.5	0.9	1.4	2.1	3.1	4.7
L (D = 4)	-	0.2	0.5	0.9	1.4	2	2.9	4.2
L (D = 5)	-	0.2	0.5	0.8	1.3	2	2.8	3.9
L (D = 6)	-	0.2	0.5	0.8	1.3	1.9	2.7	3.7

Example:

A cabinet needs to be fitted with a Klar Door with an overlay of 16 mm. Calculate the different measurements required for installation and the space needed to open the door keeping in mind the following:

Distance from the bottom and top edge of the door to the milled cavity for the corner bracket (W) = 2.5 mm

Distance from the hinge-side edge of the door to the milled cavity for the corner bracket (D) = 4 mm.

Overlay (S) = 16 mm

Visible thickness of the cabinet top panel when shutter is closed (Y) = 1 mm

--> For Profile drilling, we use the values of W and D, which are given as 2.5 mm and 4 mm respectively.

For Cabinet top and bottom panel drilling, we already have the values of S and Y from the given data as 16 mm and 1 mm respectively.

Now, we need to find the distance from the inside edge of the cabinet side panel to the drilled cavity for the hinge body (A) = $(17 + D) - S = (17 + 4) - 16 = 5 \text{ mm}$

Then we find the distance from the cabinet top panel edge (X) = $W + Y = 2.5 + 1 = 3.5 \text{ mm}$

To find the the space for the door's opening L, we refer to the above table for door thickness T (thickness of the Klar profile in this case) = 19.2 mm

We find L = 0.2 mm i.e., you need extra space of 0.2 mm to accommodate the shutter opening.

Installation of Klar Door - Glass

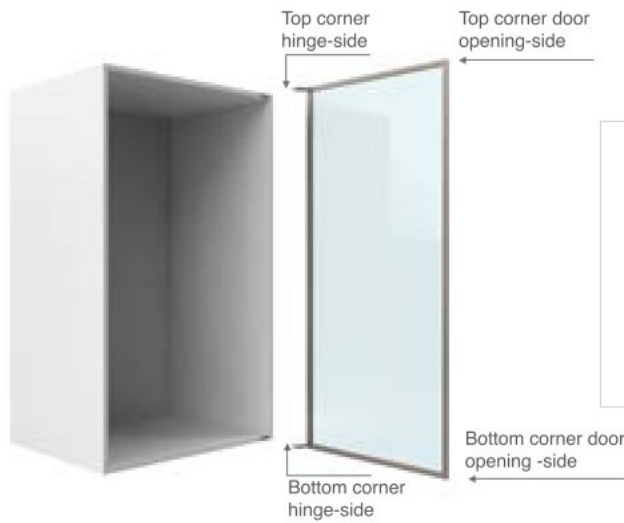

1. Miter cut the profiles in the desired length.



2. Make the milling in the profiles (that form the top and bottom corners of the door on the hinge-side) to fit the corner bracket.



3. Insert the corner bracket from the Klar Door Hinge set into the profiles that form the top hinge-side corner of the door and fix it in place with the help of screws.



4. Insert the corner connector into profiles that form the top corner on the door openingside and fix it.



5. As mentioned in the earlier steps, fix the corner bracket and the corner connector into the left and right top corners to form three sides of the frame. Insert the glass along with the gasket into the frame and fix the bottom profile with the help of the remaining corner bracket and connector. The total weight of the shutter should not exceed 20 kg.



6. Insert the Klar hinge into the grooves of the corner brackets in stalled on the top and bottom corners of the door on the hinge-side.



7. Make cavities according to the technical specifications for the Klar hinge body in the top and bottom panels of the cabinet.



8. Insert the hinged door into the top and bottom wooden panel cavities and screw it tightly. You can accurately align the door with the help of the adjustable screws in the hinge

KITCHEN HANDLES



Stainless Steel Furniture Handles



1 SS Matt



2 SS Matt



3 SS Matt



4 SS Matt



5 SS Matt



6 SS Matt

ORDERING INFORMATION

Product Description		Article No.
1	Stainless Steel 10mm handle c/c 96mm	115.77.051
	c/c 128mm	115.77.052
	c/c 160mm	115.77.053
	c/c 224mm	115.77.055
	c/c 320mm	115.77.058
2	Stainless Steel 10mm round x 10mm square handle c/c 224 mm	115.95.005
	c/c 320 mm	115.95.008
3	Stainless Steel 10mm x 10mm handle c/c 128mm	115.68.002
	c/c 192mm	115.68.004
	c/c 320mm	115.68.008
	c/c 640mm	115.68.014
4	Stainless Steel 25mm x 12mm handle c/c 128mm	115.46.002
	c/c 192mm	115.46.004
	c/c 320mm	115.46.008
	c/c 640mm	115.46.014
5	Stainless Steel 12mm x 6mm square handle c/c 96mm	100.68.001
	c/c 128mm	100.68.002
	c/c 160mm	100.68.003
	c/c 224mm	100.68.005
	c/c 320mm	100.68.008
6	Stainless Steel 10 mm round rail bar handle c/c 96mm	101.20.071
	c/c 128mm	101.20.072
	c/c 160mm	101.20.073
	c/c 224mm	101.20.075
	c/c 320mm	101.20.078

Stainless Steel Furniture Handles



1 SS Matt



2 SS Matt



3 SS Matt



4 SS Matt

ORDERING INFORMATION

	Product Description	Article No.
1	Stainless Steel 10mm x 10mm square handle c/c 320mm	115.39.008
2	Stainless Steel 8mm round bar c/c 96mm c/c 128mm c/c 160mm c/c 224mm	116.10.051 116.10.052 116.10.053 116.10.055
3	Stainless Steel 10mm round bar handle c/c 96mm c/c 128mm c/c 160mm c/c 224mm	117.40.051 117.40.052 117.40.053 117.40.055
4	Stainless Steel 10mm round bow handle c/c 96mm c/c 128mm c/c 160mm c/c 224mm	100.69.001 100.69.002 100.69.003 100.69.005

Stainless Steel Furniture Handles



1 SS Matt



2 Polished Stainless Steel



3 Polished Stainless Steel

ORDERING INFORMATION

Product Description		Article No.
1	Stainless Steel Matt, Hollow Bar Handle, Dia14mm, c/c 96mm c/c 160mm c/c 224mm c/c 320mm	109.85.034 109.85.036 109.85.038 109.85.039
2	Delux, Zinc Alloy, Polished Stainless Steel c/c 96mm	110.08.011
3	Delux, Zinc Alloy, Polished Stainless Steel c/c 96mm	103.84.061

Zinc Alloy Furniture Handles



1 Chrome Plated Polished



2 Chrome Plated Polished



3 Chrome Plated Polished



4 Nickel Plated, Brushed



5 Chrome Plated Polished



6 Nickel Plated, Brushed



7 Chrome Plated Polished



8 Chrome Plated Polished



9 Chrome Plated Polished

ORDERING INFORMATION

Product Description	Dim. (mm)	Hole centres (mm)	Article No.
1 Furniture Knob c/c 32 mm, Zinc Alloy, Chrome Plated Polished	40 x 24	32	110.34.271
2 Furniture Knob c/c 96 mm, Zinc Alloy, Chrome Plated Polished	96 x 24	96	110.34.274
3 Furniture Handle c/c 160 mm, Zinc Alloy, Chrome Plated Polished	196 x 30	160	110.34.216
Furniture Handle c/c 192 mm, Zinc Alloy, Chrome Plated Polished	228 x 30	192	110.34.217
4 Furniture Handle c/c 160 mm, Zinc Alloy, Nickel Plated Brushed	196 x 30	160	110.34.616
Furniture Handle c/c 192 mm, Zinc Alloy, Nickel Plated Brushed	228 x 30	192	110.34.617
5 Furniture Handle c/c 160 mm, Zinc Alloy, Chrome Plated Polished	180 x 26	128/160	110.34.236
Furniture Handle c/c 224 mm, Zinc Alloy, Chrome Plated Polished	244 x 26	192/224	110.34.238
6 Furniture Handle c/c 160 mm, Zinc Alloy, Nickel Plated Brushed	180 x 26	128/160	110.34.636
Furniture Handle c/c 224 mm, Zinc Alloy, Nickel Plated Brushed	244 x 26	192/224	110.34.638
7 Furniture Handle c/c 228mm & 320mm, Polished Chrome	330 x 28	228/ 320	101.11.257
8 Furniture Handle c/c 448mm & 480mm, Polished Chrome	488 x 28	448/480	101.11.259
9 Furniture Handle c/c 320mm & 352mm, Polished Chrome	419 x 32	320/352	101.11.238

Zinc Alloy Furniture Handles



1 Chrome Plated Polished



2 Nickel Plated Brushed



3 Nickel Plated Brushed



4 Chrome Plated Polished



5 Nickel Plated Brushed



6 Chrome Plated Polished



7 Chrome Plated



8 Nickel Plated Brushed

ORDERING INFORMATION

	Product Description	Dim. (mm)	Hole centres (mm)	Article No.
1	Furniture Handle c/c 192mm, Zinc Alloy, Chrome Plated Polished	227 x 35	192	106.69.267
	Furniture Handle c/c 320mm, Zinc Alloy, Chrome Plated Polished	355 x 35	320	106.69.268
2	Furniture Handle c/c 192mm, Zinc Alloy, Nickel Plated Brushed	227 x 35	192	106.69.667
	Furniture Handle c/c 320mm, Zinc Alloy, Nickel Plated Brushed	355 x 35	320	106.69.668
3	Furniture Handle c/c 160/192mm, Zinc Alloy, Nickel Plated Brushed	215 x 30	160/192	110.34.627
4	Furniture Handle c/c 160mm, Zinc Alloy, Chrome Plated Polished	180 x 28	160	110.34.286
	Furniture Handle c/c 192mm, Zinc Alloy, Chrome Plated Polished	212 x 28	192	110.34.287
5	Furniture Handle c/c 160mm, Zinc Alloy, Nickel Plated Brushed	180 x 28	160	110.34.686
	Furniture Handle c/c 192mm, Zinc Alloy, Nickel Plated Brushed	212 x 28	192	110.34.687
6	Furniture Handle c/c 160/192mm, Zinc Alloy, Chrome Plated Polished	204 x 32	160/192	110.34.257
7	Furniture Handle c/c 160/192mm, Chrome Plated	212 x 30	160/192	106.61.214
	Furniture Handle c/c 288/320mm, Chrome Plated	304 x 30	288/320	106.61.217
8	Furniture Handle c/c 160/192mm, Nickel Plated Brushed	212 x 30	160/192	106.61.014
	Furniture Handle c/c 288/320mm, Nickel Plated Brushed	340 x 30	288/320	106.61.017

Designer Furniture Knobs (Stainless Steel)



1 Furniture Round Knob



2 Furniture Round Knob



3 Furniture Round Knob



4 Furniture Knob



5 Furniture Knob



6 Furniture Knob



7 Furniture Knob



8 Furniture Knob

ORDERING INFORMATION

Product Description		Diameter (mm)	Article No.
1	Furniture Round Knob, Dia 20 x 24mm, Stainless Steel Matt	20 x 24	155.01.512
2	Furniture Round Knob, Dia 25 x 25mm, Stainless Steel Matt	25 x 25	134.28.080
3	Furniture Round Knob, Dia 32 x 26mm, Stainless Steel Matt	32 x 26	134.28.100
4	Furniture Knob, Dia 25mm, Stainless Steel Matt	25	134.79.002
5	Furniture Knob, Dia 30mm, Stainless Steel Matt	30	134.28.000
6	Furniture Knob, Dia 25mm, Stainless Steel Matt	25	134.81.002
7	Furniture Knob, Dia 30mm, Stainless Steel Matt	30	134.29.004
8	Furniture Knob, Dia 20mm, Zinc Alloy, Chrome Plated Polished	20	110.35.271
	Furniture Knob, Dia 20mm, Zinc Alloy, White Matt		110.35.771
	Furniture Knob, Dia 20mm, Zinc Alloy, Nickel Plated Brushed		110.35.671
	Furniture Knob, Dia 20mm, Zinc Alloy, Black Matt		110.35.371

New Black Finish Handles



1 Evolve Furniture Handle Black



2 Black Matt Round Flush Handle



3 Black Matt Flush Handle

ORDERING INFORMATION

Product Description		Dim. (mm)	Hole centres (mm)	Article No.
1	Evolve Furniture Handle Black 160mm c/c	-	160	103.84.100
	Evolve Furniture Handle Black 224mm c/c	-	224	103.84.101
	Evolve Furniture Handle Black 320mm c/c	-	320	103.84.102
2	Black Matt Round Flush Handle Dia 50mm	50	-	103.84.110
3	Black Matt Flush Handle 164mm	164	-	100.00.810

Aluminium Flush Handles



1 Stainless Steel Coloured



2 White Coloured



3 Stainless Steel Coloured



4 Aluminium Silver Coloured

ORDERING INFORMATION

Product Description		Cut-out Dim. (mm)	Article No.
1	Flush Handle Size: 110 x 85mm, Stainless Steel Coloured	110 x 85	152.16.000
	Flush Handle Size: 150 x 85mm, Stainless Steel Coloured	150 x 85	152.16.001
2	Flush Handle Size: 110 x 85mm, Frosty White Coloured	110 x 85	152.16.710
	Flush Handle Size: 150 x 85mm, Frosty White Coloured	150 x 85	152.16.711
3	Flush Handle Size: 137 x 42mm Aluminium, Stainless Steel Coloured	137 x 42	151.86.021
	Flush Handle Size: 169 x 42mm Aluminium, Stainless Steel Coloured	169 x 42	151.86.022
	Flush Handle Size: 201 x 42mm Aluminium, Stainless Steel Coloured	201 x 42	151.86.023
	Flush Handle Size: 329 x 42mm Aluminium, Stainless Steel Coloured	329 x 42	151.86.027
4	Flush Handle Size: 106 x 30mm, Aluminium Silver Coloured	106 x 30	155.01.130

Zinc Alloy Flush Handles



1 2 Flush Handle



3 Flush Handle

ORDERING INFORMATION

Product Description		Size (mm)	Article No.
1	Flush Handle, Matt Nickel, Size: 110 x 15mm	110 x 15	161.30.600
2	Flush Handle, Polished Chrome, Size: 110 x 15mm	110 x 15	161.30.200
3	Flush Handles, Zinc Alloy Aluminium Coloured, Size: 80 x 29mm	80 x 29	152.13.900*

* Special Order

Aluminium Grip Profile Handles

In today's modern kitchens and common areas, profile handles, commonly known as 'Gola Profile' are very popular and enable endless creations. Häfele's range of profile handles provide a streamlined, handle-less look to your kitchen and are made up of high-quality aluminium. The profiles, available in 2.5m length, can be easily cut to size as per requirement and can be attached by Stainless Steel connector brackets to the cabinet sides. Häfele's Profile handles come in different finishes, viz. Silver Anodized, White & Black.

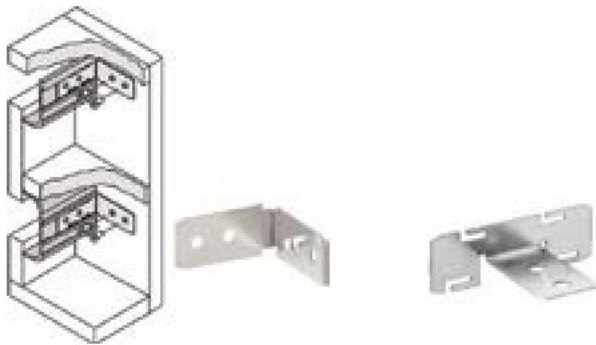

1] Fixing Bracket

2] Bracket



3] Silver Anodized/ White/ Black

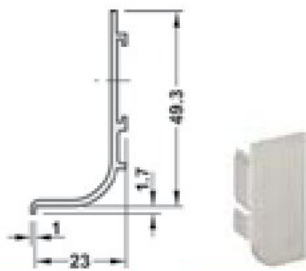

4] End cap for L shaped profile



5] Silver Anodized/ White/ Black



6] End cap for C shaped profile



7] Outward 90° Connector for C-shape Gola Profile



8] Inward 90° Connector for L-shape Gola Profile



9] Outward 90° Connector for L-shape Gola Profile



10] Inward 90° Connector for C-shape Gola Profile

ORDERING INFORMATION

Product Description	Stainless Steel	Silver Anodized	White	Black
1] Fixing Bracket for Gola Profile Handles, Stainless Steel 44 x 44mm	126.37.990	-	-	-
2] Gola Profile Bracket, SS Polished	126.37.988	-	-	-
3] Grip Profile Handle, L Shape, 2500 mm	-	126.37.900	126.37.700	126.37.301*
4] End cap for L shaped profile (Right hand side) End cap for L shaped profile (Left hand side)	-	126.37.997 126.37.998	126.37.977 126.37.978	126.37.937* 126.37.938*
5] Grip Profile Handle, C Shape, 2500 mm	-	126.36.900	126.36.700	126.36.300*
6] End cap for C shaped profile	-	126.37.996	126.37.976	126.37.936*
7] Outward 90° Connector For C-shape Gola Profile	-	126.37.986	126.37.771	126.37.371*
8] Inward 90° Connector For L-shape Gola Profile	-	126.37.980	126.37.774	126.37.374*
9] Outward 90° Connector For L-shape Gola Profile	-	126.37.985	126.37.775	126.37.375*
10] Inward 90° Connector For C-shape Gola Profile	-	126.37.981	126.37.770	126.37.370*

*Special Order

Aluminium Grip Profile Handles



The aluminium grip profile handles enhance the straight lines of drawers and doors in the kitchen making it more elegant.

Available in exclusive designs, these profiles are individually anodized to ensure high quality surface finish.

The high quality processing is reflected at the smooth edges of the profiles thus making it a very user friendly product.

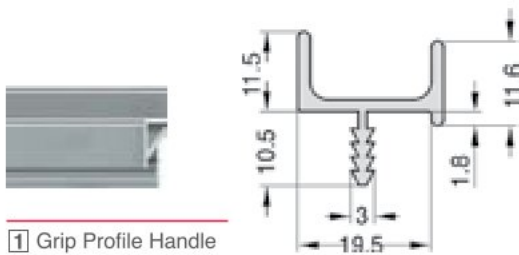

1 Grip Profile Handle

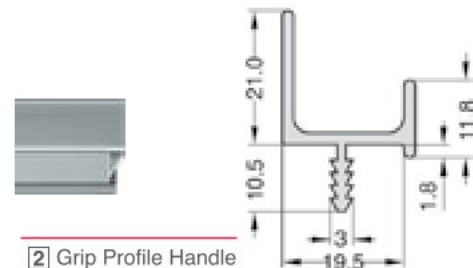

2 Grip Profile Handle



3 Grip Profile Handle

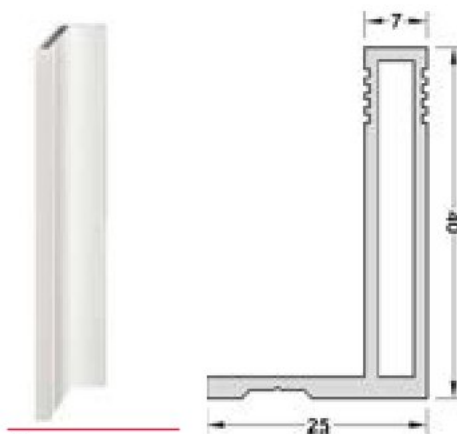

4 Profile Handle

ORDERING INFORMATION

Product Description		Length (mm)	Article No.
1	Profile Grip, Aluminium, Silver Coloured, Anodized, Size: 11.5 x 19.5 x 2500mm	2500	126.20.905
2	Profile Grip, Aluminium, Silver Coloured, Anodized, Size: 21 x 19.5 x 2500mm	2500	126.21.902
3	Profile Handles, Overall Length 297mm(Handle 217mm), Finish Polished Chrome	297	126.26.273
4	Profile Handle for Wood Sliding Door, Aluminium Silver Anodized, 2500mm	2500	126.12.900

Aluminium Grip Profile Handles

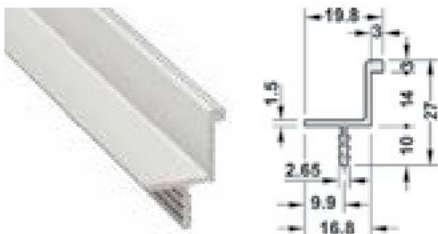

1 Grip Profile Handle

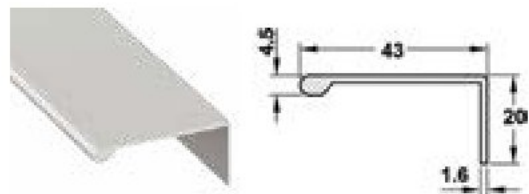

2 Grip Profile Handle

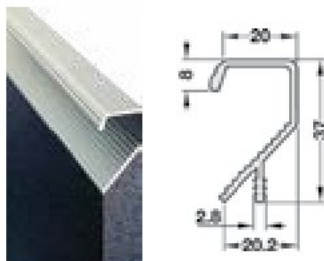

3 Grip Profile Handle

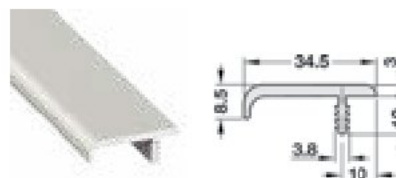

4 Grip Profile Handle

ORDERING INFORMATION

Product Description	Length (mm)	Article No.
1 Aluminium Grip Profile, 2500 mm, Aluminium Silver Anodized	2500	126.35.945
2 Aluminium Grip Profile Handle, 3000mm, Aluminium Silver Anodised	3000	126.27.907
3 Grip Profile Handle, 2500 mm, Aluminium Anodized	2500	126.34.925
4 Grip Profile Handle, 3000 mm, Aluminium Anodized	3000	126.27.908

Aluminium Grip Profile Handles

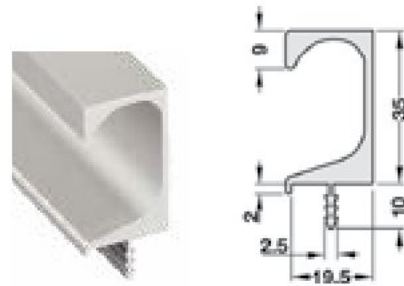

1 Grip Profile Handle

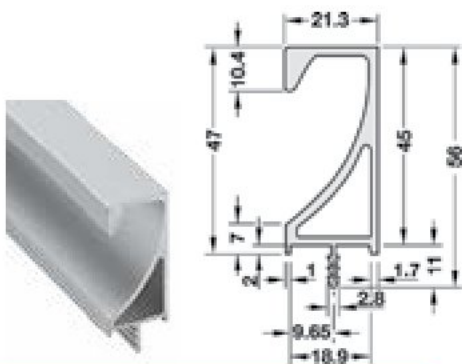

2 Grip Profile Handle

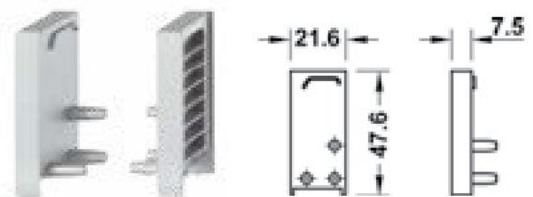

3 End Caps

ORDERING INFORMATION

	Product Description	Length (mm)	Article No.
1	Aluminium Profile G-Shape 3000mm, Silver Anodized	3000	126.07.933
	Aluminium Profile G-Shape 3000mm, SS Brushed	3000	126.07.033
2	Aluminium Profile Handle 2500mm, Aluminium Silver Anodized	2500	126.39.925
3	End Cap for 126.39.925 RHS Plastic Silver Coloured	-	126.39.997
	End Cap for 126.39.925 LHS Plastic Silver Coloured	-	126.39.998

KITCHEN
ACCESSORIES



Dish Rack & Cutlery Holder



The Dish rack series is an innovative idea designed with a stainless steel draining board and clear plastic supports that can be easily adjusted on the grid. The plastic parts are made of non-toxic material and can be washed in a dish washer. Available for cabinet widths 450 mm, 600 mm and 900 mm.



1 a) b) Free standing dish rack for 450 / 600 mm cabinets



2 a) b) Built in dish rack for 600 / 900 mm cabinets



3 a) b) Built in dish rack with designer plastic holders for 600 / 900 mm cabinets



4 a) Glass & Plate rack for 600 mm cabinet width (for up to 16 plates & 4 thalis)



4 b) Glass & Plate rack for 900 mm cabinet width (for up to 22 plates & 9 thalis)

ORDERING INFORMATION

Product Description		Size (mm)	Article No.
1a	Free standing dish rack K45	Width 450	544.07.071
1b	Free standing dish rack K60	Width 600	544.07.073
2a	Built in dish rack	Width 600	544.07.083
2b	Built in dish rack	Width 900	544.07.086
3a	Built in dish rack	Width 600	544.07.093
3b	Built in dish rack	Width 900	544.07.096
4a	Classic Plate and Glass Drain System- 600mm Cabinet	Width 600	544.00.253
4b	Classic Plate and Glass Drain System- 900mm Cabinet	Width 900	544.00.256

Wall Hanging Bracket

Wall hanging brackets are fixed to hang cabinets to the wall. These hanging brackets feature a slide on/slide off cover within and completely conceals the adjustment and fixing screws, gives it a neat and cleaner appearance. Both adjustment screws face the outside of the carcass for easy accessibility. This allows easy adjustment even if the cabinet is loaded. The cover is available in several finishes white plastic colours or metal, satin nickel plated to co-ordinate with the hinges. Wall Hanging Brackets are highly durable and can take load up to 200 kgs. This can be adjusted - up to 25mm horizontally and up to 28mm vertically.



1 Hanging bracket



2 Steel cover



3 Plastic cover



4 Wall plate

ORDERING INFORMATION

Product Description	Finish	Article No.
1 Visible hanging brackets, loading capacity: up to 65 kg.		290.05.750 (Right hand) 290.05.751 (Left hand)
2 Steel cover for bracket	Brushed nickel	290.05.680 (Right hand) 290.05.681 (Left hand)
3 Plastic cover for bracket	White	290.05.682 (Right hand) 290.05.683 (Left hand)
4 Steel wall plate size 26 x 60 mm, loading capacity: up to 200 kg		290.10.901

Concealed Hanging Bracket



These totally concealed hangers avoid any alteration in the design of the furniture unit. This system allows the bracket to be fastened to the unit without using screws. The unique feature of this solution is, it gives freedom of design. Concealed hangers are highly durable and can take a maximum load of 65 kgs.

Concealed hangers can be adjusted - up to 25mm horizontally and up to 18mm vertically.

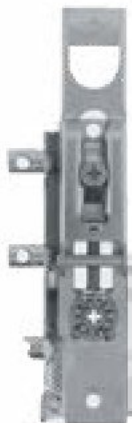

1 Concealed Hanger



2 White plastic cap



3 Wall plate



ORDERING INFORMATION

Product Description		Article No.
1	Concealed hanger, loading capacity: up to 65 kg	290.37.900 (Right Hand) 290.37.901 (Left Hand)
2	White plastic cap (ø10 mm)	290.37.790
3	Steel wall plate size 26 x 60 mm, loading capacity: up to 200 kg	290.10.901

Mid-Way Systems

The new kitchen midway systems from Häfele are the ideal storage solutions for any kitchen. If frequently used items like spices are stored in cabinets or shelves they may be troublesome to access. Rather than having to rummage around in the depths of a cabinet it makes a lot more sense to have these objects at arms reach.

Material: Aluminum/ Bamboo

Finish: Stainless Steel Optic



1 Wall hanging track



2 Multi purpose rack



3 Multi purpose rack with 6 glass bottles



4 Shelf with storage boxes



5 Paper towel holder

ORDERING INFORMATION

	Product Description	Width (mm)	Length (mm)	Depth (mm)	Article No.
1	Wall hanging track-stainless steel optic	600	18	20	521.86.000
	Wall hanging track-stainless steel optic	1200	18	20	521.86.001
	Wall hanging track-stainless steel optic	1500	18	20	521.86.002
	Wall hanging track-stainless steel optic	1800	18	20	521.86.003
2	Multi purpose rack-stainless steel optic / ACP in white	485	90	80	521.87.000
3	Multi purpose rack + 6 nos. Glass oil/ vinegar/sauce dispensers -stainless steel optic / ACP in white / glass	485	90	80	521.87.010
4	Shelf with storage boxes (2 nos.) - Stainless steel optic / Oak	485	105	80	521.87.420
5	Paper towel holder -stainless steel optic / Oak	485	90	80	521.87.432

Mid-Way Systems



1 Towel rail



2 Multi hooks



3 Hook



4 Spice can holder



5 Cutting board

ORDERING INFORMATION

Product Description	Width (mm)	Length (mm)	Depth (mm)	Article No.
1 Towel rail - stainless steel optic	485	40	80	521.87.050
2 Multi hooks - stainless steel optic	485	35	80	521.87.060
3 Hook - stainless steel optic / oak	30	20	40	521.87.070
4 Spice can holder - stainless steel optic / stainless steel	485	61.50	80	521.87.090
5 Cutting board - oak/stainless steel optic	360	240	30	521.88.400

Plasma Mini Lift

The Plasma Mini Lift is a small all-round electric TV Lift. It can be used in many kind of applications such as kitchens cupboards, bed ends, office furniture, campers, speedboats and more. These quiet, stable, remote controlled TV lifts are especially designed for flat screen TV's 460 mm travel, to accommodate small (up to 24") flat screen TV's. Each lift comes with a radio wave remote control - it can be used from anywhere within the room unlike infrared that would require pointing to a visible receiver with both remote and manual switch operation. It has an installation depth of just 70 mm and weight capacity is 50 kg.

Features

- Easy way to mount flat Screen TV in the kitchen
- Fittings made of steel (Silver - RAL 9006) finish
- Set includes radio frequency remote control

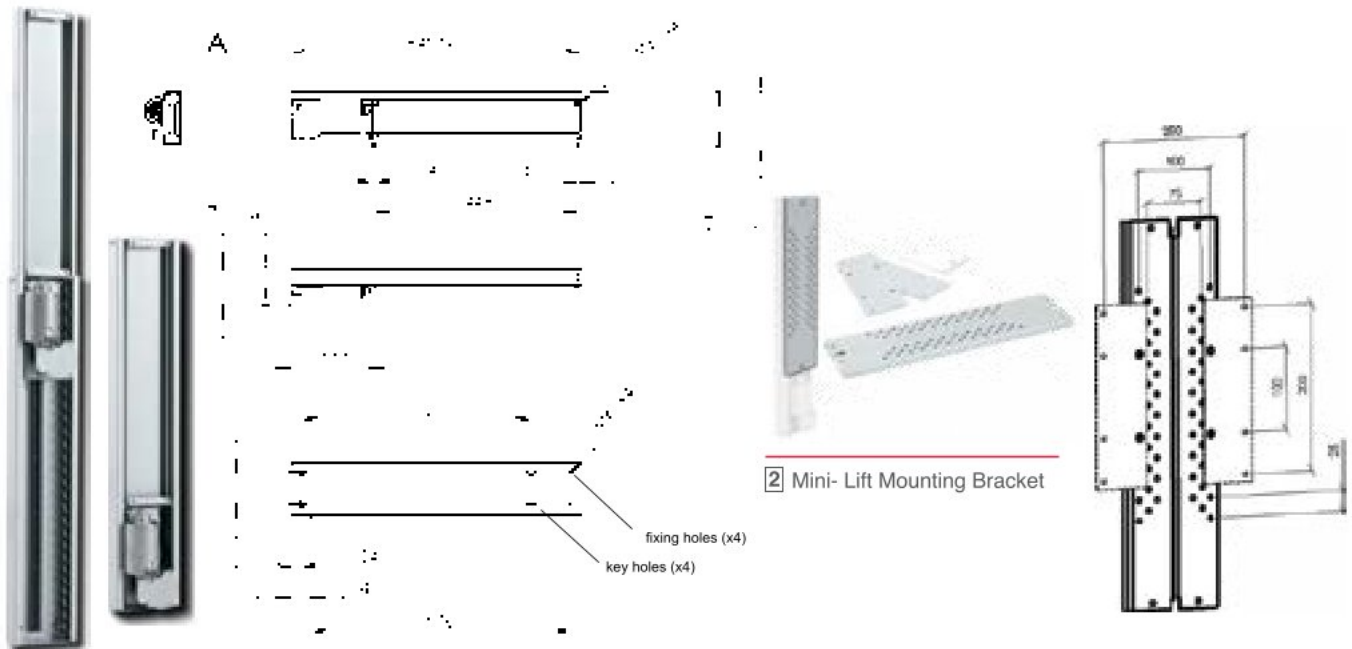

1 Mini-Lift Flat Screen Lift



Set includes radio frequency remote control.
Cabinet and screen are not included.

Note: Cabinet Screen are not included
Please use voltage stabilizer to safe guard transformer.
Check VESA dimension and height of TV before ordering.
Need wall support to avoid vibration & shaking

Technical data

Area of application: Used in cabinets for raising and lowering flat screen televisions, kitchen cabinets, desktop screens etc.

Mounting method: Suitable for the below VESA standards

- 50 x 50
- 75 x 75
- 100 x 100
- 200 x 100
- 200 x 200

Height of mechanism: 645 mm (closed) to 1105 mm (open)

Stroke: 460 mm

Weight capacity: 50 kg (25 kg for reverse position)

Speed: 25 mm / second

Max TV Size: 24 inch

ORDERING INFORMATION

Product Description	Article No.
1 Mini-lift flat screen lift	421.68.700
2 Mini-lift mounting bracket	421.68.431

Lunch Pull-Out Drawer Table



Optimal utilization of space is always desirable but creating additional space from what's available has now become a necessity. The Lunch Extendable Table Fitting from Häfele's Space 2 Range is a space-saving system that consists of a pull-out table top fitting stored in a space normally used for a drawer. This table fitting pulls out instantly by simply opening the hinged front of the drawer space. Created to cater to the needs of functionality in small spaces, Lunch is ideal for small kitchens and kitchenettes needing a tabletop for breakfast or simply as an extension of the work top for preparing meals.

- **Material:** Aluminium
- **Finish:** Stainless Steel
- **Mechanism:** Pull-out extendable slides
- **Max. weight carrying capacity:** 60 kg
- **Dimensions:** 450-900 (W) mm
- **Number of planes:** 2
- **Cycle testing:** 40,000 cycles
- 5 years warranty w.r.t. friction and use as per Häfele warranty document

Other Details:

- One article for variable widths
- Smooth and silent functionality
- Locking feature is available
- Manufactured and tested in Italy

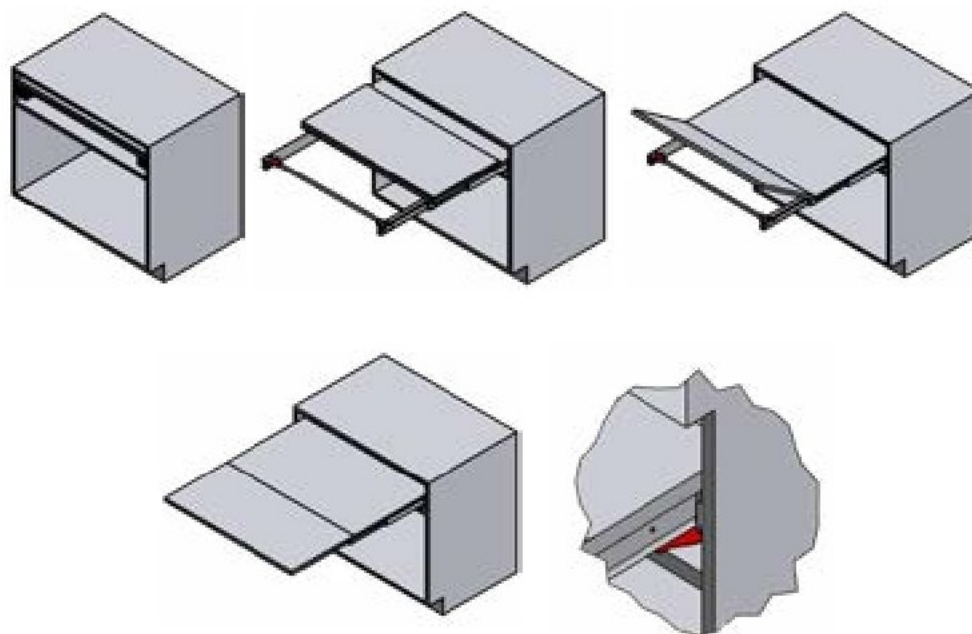

ORDERING INFORMATION

Product Description	Article No.
1 Lunch silent extension table + Kit cap (W450- 900 mm)	505.75.925

Evolution Naked XL Pull Out Table with Bridge Leg

Fittings that could be brought out or tucked away in seconds whenever desired are the need of the hour with space constraints everywhere and a desire to have multifunctional open areas. Häfele brings to you Evolution Naked XL from the Space2 Range of Transformable Furniture Fittings, which is an entire dining table that folds away into your cabinet. It is a perfect solution for comfortable family dinners or can double up as a snack table during small get togethers. Evolution Naked XL comes with a bridge leg which is attached to the cabinet shutter providing additional support to the table. There is also a provision to detach the cabinet front from the leg to create an additional seating place around the table.

- **Material:** Aluminium
- **Finish:** Stainless Steel
- **Mechanism:** Pull-out extendable slides
- **Max. weight carrying capacity:** 100 kg
- **Dimensions:** 900 (W) mm
- **Number of planes:** 3
- 5 Years Warranty w.r.t. function and use as per Häfele warranty document

Other Details :

- Smooth and silent functionality
- Cabinet application, comes with legs
- Locking feature is available
- Manufactured and tested in Italy

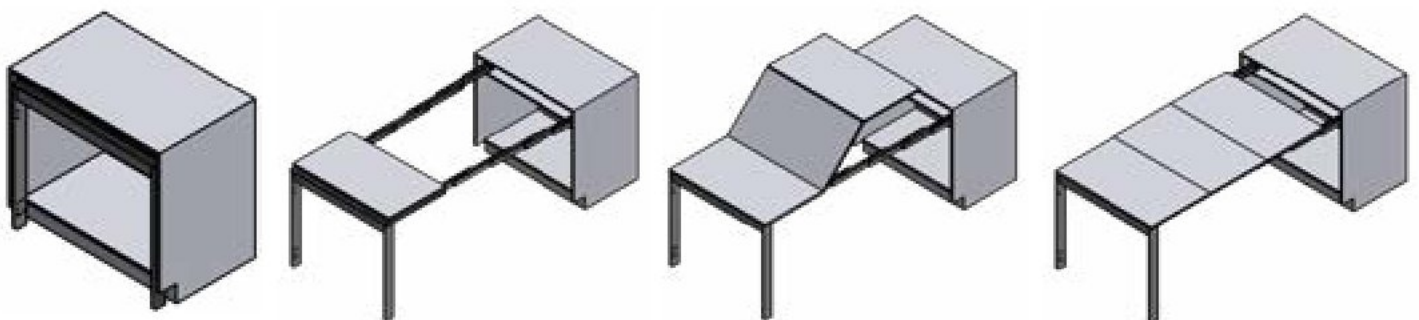

ORDERING INFORMATION

Product Description	Article No.
1 Evolution Naked XL, W= 900 mm	505.75.995

Oplà Top Pull-Out Worktop Flush With Surface



Happiness is getting an extra space on your existing table or counter top with a slight lift and fold. Extend your counter top space in kitchens with a small working area by means of Oplà Top from Häfele's Space2 Range of Transformable Furniture Fittings. It is an extendable table fitting that enables the table top to be pulled out of the drawer unit in a manner that it flushes with the kitchen or furniture worktop. This fitting can be used as a small table for breakfast or as an extension to the kitchen worktops in small kitchens and kitchenettes.

- **Material:** Aluminium
- **Finish:** Stainless Steel
- **Mechanism:** Pull-out flush top extendable slides
- **Max. Weight** 40 Kg
- **carrying capacity:**
- **Dimensions:** 450-900 (W) mm
- **Number of planes:**1
- **Cycle testing:** 35,000 cycles
- 5 Years warranty w.r.t. function and use as per Häfele warranty document

Other Details:

- One Article for Variable Widths
- Smooth and Silent Functionality
- Manufactured and Tested in Italy

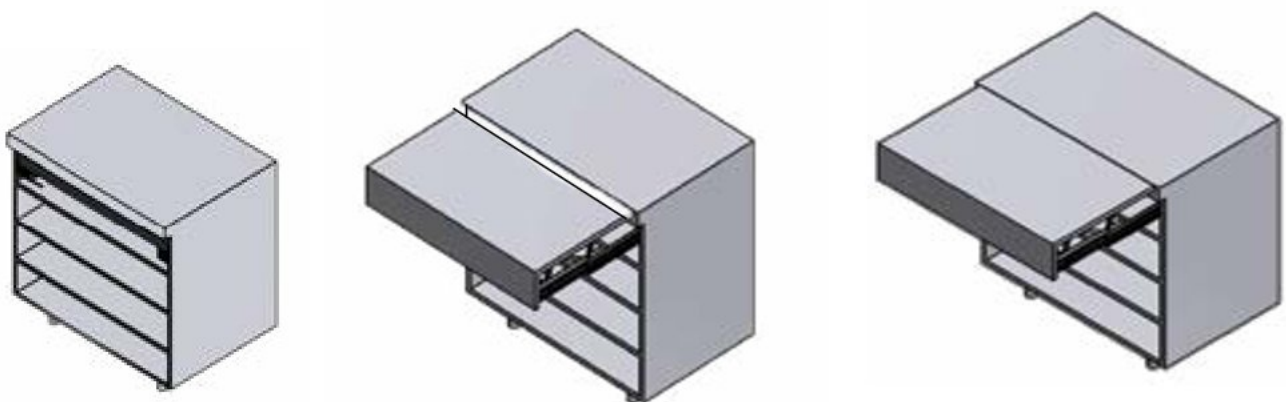

ORDERING INFORMATION

Product Description	Article No.
1 Oplà Top Silent + Kit Cap (W450-900mm)	505.75.945

Axis Linear Counter Top Extension

Wasted space is a crime; additional space is a boon. Adhering to this motto, the Axis Linear Countertop Extension from Häfele's Space2 Range of Lifestyle Fittings upgrades your kitchen worktop area with a linearly sliding countertop which can be fitted onto your existing kitchen and furniture surfaces. It is completely hidden under the sliding countertop extension and facilitates a smooth and effortless motion. This countertop extension can be moved in three ways - horizontal, vertical and diagonal by just changing the installation technique.

- **Material:** Mild steel
- **Finish:** Zinc plated
- **Mechanism:** Extendable slides
- **Min. Internal countertop extension depth:** 550 mm (model no.600)/ 850 mm (model no. 900)/ 1150 mm (model no. 1200)
- **Weight carrying capacity:** 120 kg (can be increased up to 240 kg with central extendable slides)
- **Movement:** Linear (Horizontal, Vertical and Diagonal)*

Other Details:

- Invisible Mechanism
- Manufactured and Tested in Italy

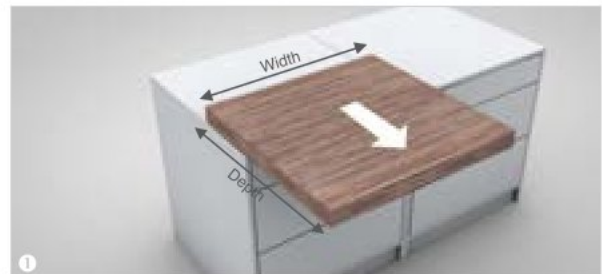
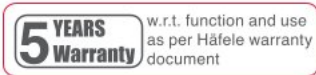

Countertop Extension Width	Number of Extending Slides	Number of Central Extendable Slides
Up to 1500 mm	2	--
1500 to 2400 mm	2	1
2400 to 3000 mm	2	2

* All the three movements can be achieved with a single fitting for a particular width and depth. The type of movement changes based on the installation of the fitting.

Note 1: For horizontal and vertical movements, countertop extension depth is the dimension along which Axis Linear moves (as shown by the arrow in the images) and countertop extension width is the dimension perpendicular (at 90°) to the depth

Note 2: For diagonal movement, the countertop extension depth and width change based on the angle from where you are viewing it.

Note 3: Length of Extension Protrusion is the value by which the countertop extension extends outside your kitchen surface/ countertop. These values are for horizontal and vertical movements; for diagonal movement.

ORDERING INFORMATION

	Model No.	Min. Internal Countertop Extension Depth (mm)	Length of Extension Protrusion (mm) [Note 3]	Article No.
Extending Slides (For countertop extension widths up to 1500 mm)	600	550	390	505.79.901
	900	850	590	505.79.902
	1200	1150	790	505.79.903
Central Extendable Slides (For countertop extension widths more than 1500 mm)	600	550	390	505.79.911
	900	850	590	505.79.912
	1200	1150	790	505.79.913

Note: 1. Article No. 505.79.901-505.79.903 kit contains pair of runners and screws to connect.
 2. Article No. 505.79.911- 505.79.913 kit contains 1 pc of runner and screws to connect.

Work Top Hot Rods



Area of application: For worktops and furniture made from oiled wood, laminate, glass, granite, stone, acrylic or slate

- **Material:** Zinc alloy
- **Finish:** Stainless steel coloured
- **Version:** Resistant against heat (up to 200 °C) and moisture
- **Dimensions** 13 x 7 mm
(W x H):

Supplied with
1 Set consisting of 6 protection rails



ORDERING INFORMATION

Product Description	Dimension (L x W x H) mm	Article No.
1 Kitchen Worktop Hot Rods, Self Adhesive	450 x 13 x 7	808.90.091

Libra H1

- Innovative family of concealed cabinet hangers
- Resistant and reliable solution thanks to the sensibly thick zinc-coated steel body
- Libra H1 is the unhandled version to be fixed behind the rear panel through three wood screws.
- Independent vertical and in-depth adjustment to easily and quickly align the cabinet against the wall.
- ANTI-TURNOVER device for domestic safety to guarantee fast locking of the cabinet against the wall plate.
- Adjustments to be carried out from the inside of the cabinet through a hole covered with alternative designed and small cover caps.
- Wide range of very thick and hardened new wall plates concept, as well as one type of wall bar, with optimized position of the fixing oval holes, to facilitate correct positioning and to reduce loading stress either on the wall plates/bar or on the plugs
- Capacity loading 75 Kilos per piece (150 Kilos per pair)
- Steel, zinc alloy and plastic according to related version
- In accordance with the European Regulation DIN 68840



1 Libra H1

ORDERING INFORMATION

Product Description	Article No.
1 Libra H1 (Concealed Cabinet Hanger)	290.41.750

Set 1 with white plastic cover caps.
Each Set includes wall plate, wood screws and instruction sheet.

Drilling plan for LIBRA H1 fixed under the cabinet top.

Side panel and service gap

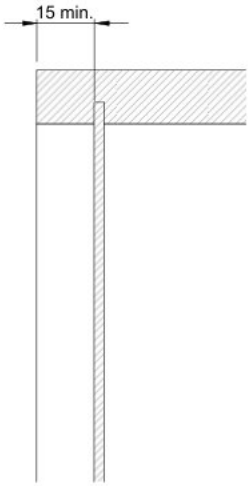

Back panel

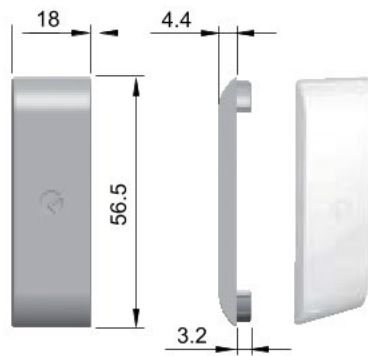
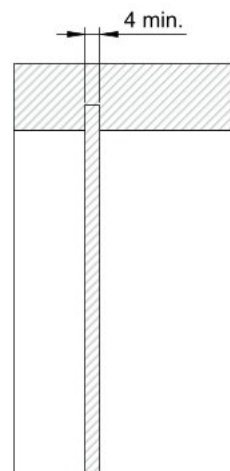
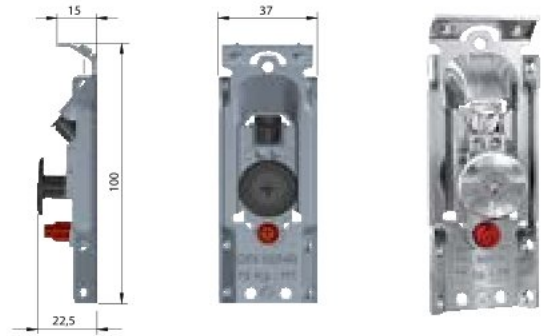
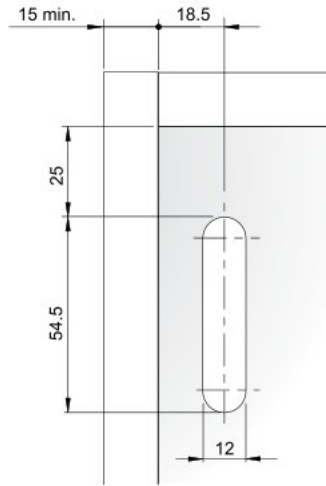

Libra CC1 - White plastic.



Libra WP1 - Steel zinc plated.

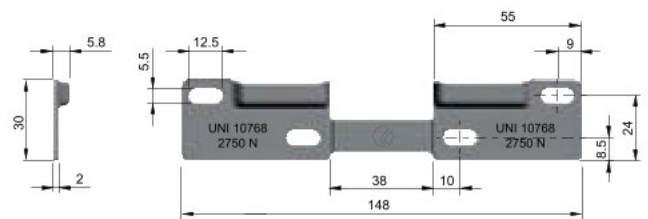

Libra H7 screw fixing with "peg joint"

Libra H7 is cabinet wall hanging bracket used to hang/float cabinets used in kitchen, living room & bathroom against wall support.

It take cares of units with drawers, swing door & drop down flap stays.

1. Excellent loading capacity, 3D adjustment & cover cap to make it discreet.
2. Comes with in built anti turnover lock.
3. Optional aluminum bar for even better capacity loading & stability.
4. Tested to carry 210 kg/pair along with 40 mm aluminum profile with 2 extra hanging point when dimension of Cabinet is 900(width)x720 (height)x600(depth) with 2 drawer.
5. Maximum: 600 depth along with drawer & no height restriction.



WARNING

The strength and the ability to withstand the stresses of LIBRA H7 assume a good state of the load-bearing wall and the plaster possibly superimposed therein. It is the responsibility of the customer to verify that the wall is in condition and of sufficient quality to support the fixing and that the tools used are compatible with the surface on which LIBRA H7 is intended to be fixed. Italiana Ferramenta may not guarantee the strength of LIBRA H7 in the absence of adequacy of the load-bearing wall.



1 Libra H7 screw fixing with "peg joint"

ORDERING INFORMATION

Product Description	Article No.
1 Libra H7 (Concealed Cabinet Hanger for livingroom, kitchen units and bathroom units)	290.41.754
2 Libra H7 Aluminium Bar H 40 mm, L=2500mm	290.01.050
3 Libra H7 Aluminium Bar H 80 mm, L=2500mm	290.01.090

Each set includes wall plate, insert nuts, fixing screws, wood dowels and instruction sheet.

LIBRA H7 SCREW FIXING WITH "PEG JOINT"



LIBRA H7 SCREW FIXING WITH "PEG JOINT"

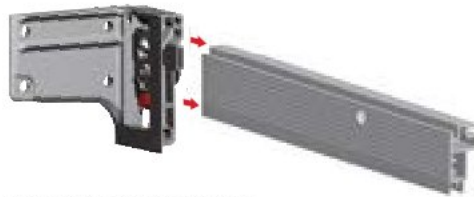



WITH ALU BAR H. 40,2 mm

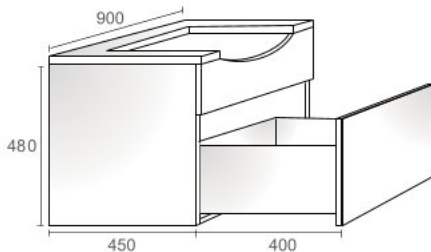
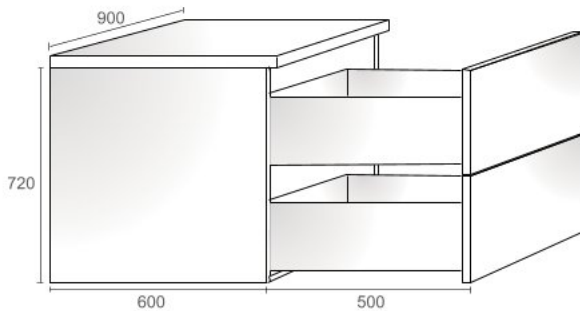
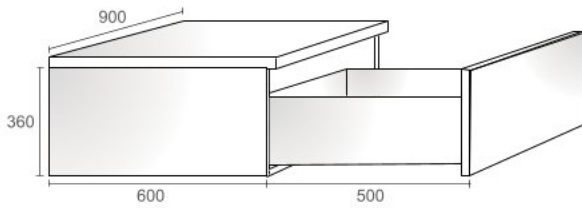
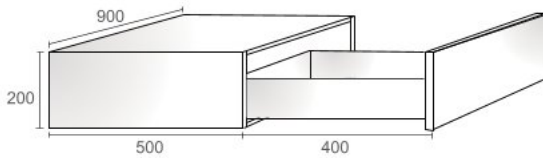

WITH ALU BAR H. 80,5 mm

LIBRA WP5



CAPACITY LOADING 			
LIBRA H7 AND CABINET WITH STRUCTURAL TOP		FURNITURE TYPE	LIBRA H7 DOWEL FIXING AND ALU BARH. 40,2 WITH 2 EXTRA HANGING POINTS
SCREW FIXING	DOWEL FIXING		
120 Kg	120 Kg	Cabinet	160 Kg
80 Kg + 30 Kg	80 Kg + 30 Kg	Cabinet + drawer	120 Kg + 30 Kg

CAPACITY LOADING 			
LIBRA H7 AND CABINET WITH STRUCTURAL TOP		FURNITURE TYPE	LIBRA H7 DOWEL FIXING AND ALU BARH. 40,2 WITH 2 EXTRA HANGING POINTS
SCREW FIXING	DOWEL FIXING		
160 Kg	150 Kg	Cabinet	180 Kg
120 Kg + 30 Kg	110 Kg + 30 Kg	Cabinet + drawer	140 Kg + 30 Kg

CAPACITY LOADING 			
LIBRA H7 AND CABINET WITH STRUCTURAL TOP		FURNITURE TYPE	LIBRA H7 DOWEL FIXING AND ALU BARH. 40,2 WITH 2 EXTRA HANGING POINTS
SCREW FIXING	DOWEL FIXING		
200 Kg	170 Kg	Cabinet	210 Kg
130 Kg + 60 Kg	100 Kg + 60 Kg	Cabinet + drawer	140 Kg + 2 x 30 Kg

CAPACITY LOADING 			
LIBRA H7 AND CABINET WITH STRUCTURAL TOP		FURNITURE TYPE	LIBRA H7 DOWEL FIXING AND ALU BARH. 40,2 WITH 2 EXTRA HANGING POINTS
SCREW FIXING	DOWEL FIXING		
200 Kg	170 Kg	Cabinet	210 Kg
160 Kg + 30 Kg	130 Kg + 30 Kg	Cabinet + drawer	170 Kg + 30 Kg

The reported data, empirically obtained, exclusively refer to the constructions and examples shown, correctly positioned and assembled by using WP5 wall plate.

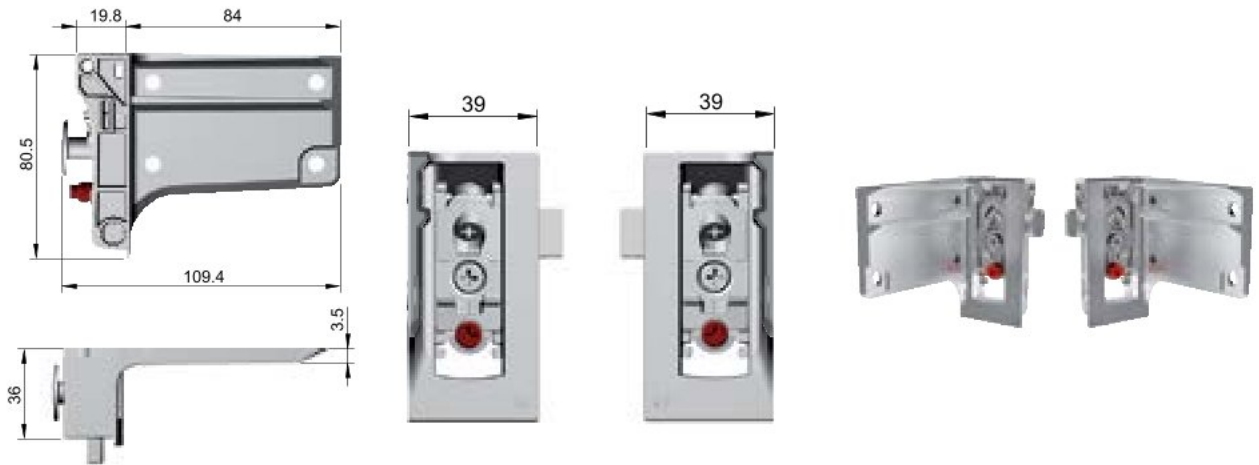

Libra WP5 screw fixing with "Peg Joint" for aluminium bar

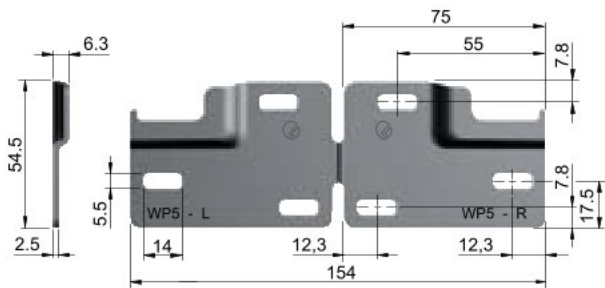

Especially conceived for LIBRA H6 and H7 for heavy duty loading.
Stress resistance calculated in Newton according to normative UNI 10768.

Libra WP5 - Steel zinc plated.

Applications and drilling plans with back panel

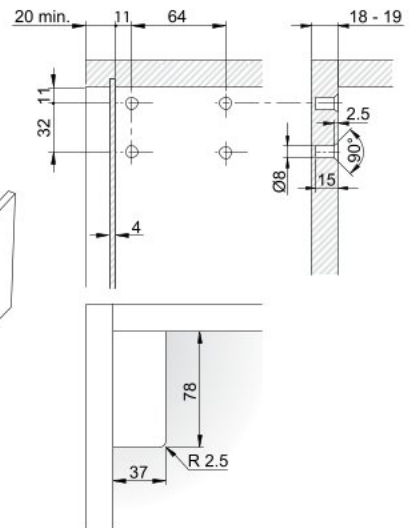
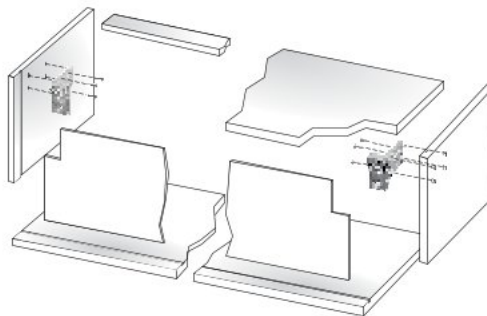
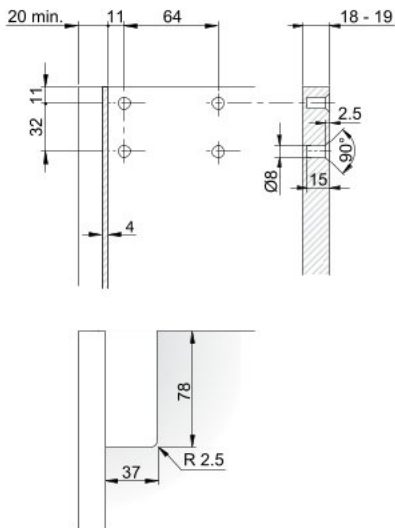

Without back panel

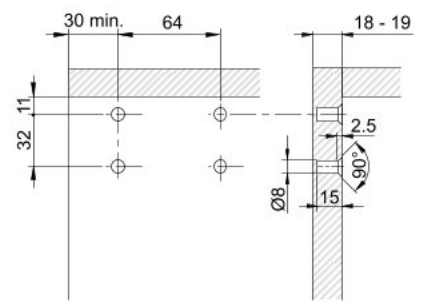
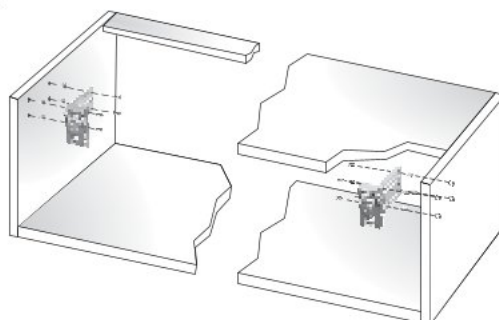
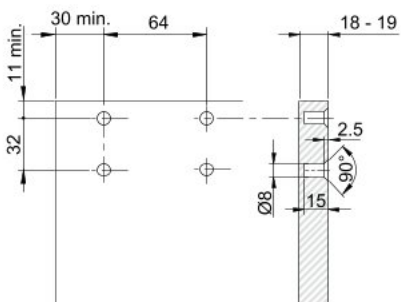

LIBRA H7 with “peg joint” for aluminium bar



1 LIBRA H7 with H. 40.2 aluminium bar.
Ideal for bathroom cabinets.



Libra H7 to be fixed on the cabinet side with aluminium bar

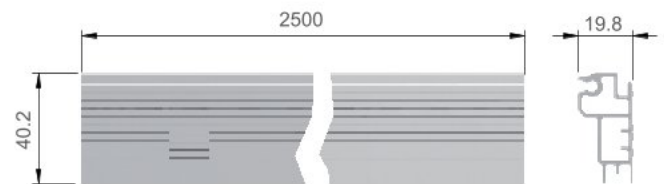

2 Libra H7 with H. 80.5 aluminium bar.
Ideal for kitchen cabinets.

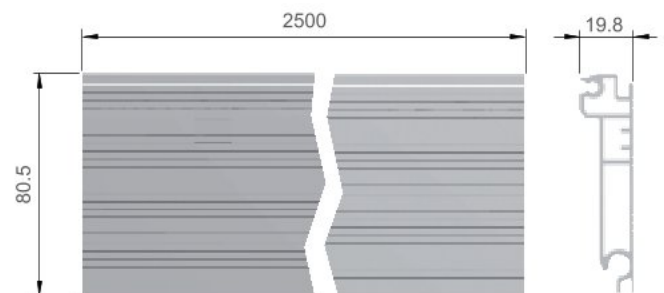

ORDERING INFORMATION

Product Description		Article No.
1	Libra H7 Aluminium Bar H 40.2 mm	290.01.040
2	Libra H7 Aluminium Bar H 80.5 mm	290.01.081

Libra H7 to be fixed on the cabinet side with aluminium bar

ASSEMBLING WITH:

H 40.2 mm ALUMINIUM BAR

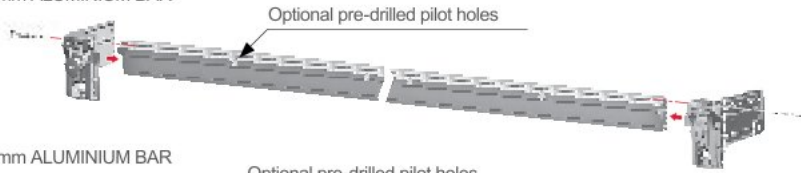

H 80.5 mm ALUMINIUM BAR

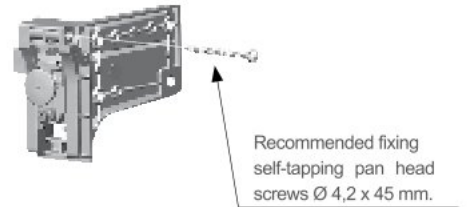
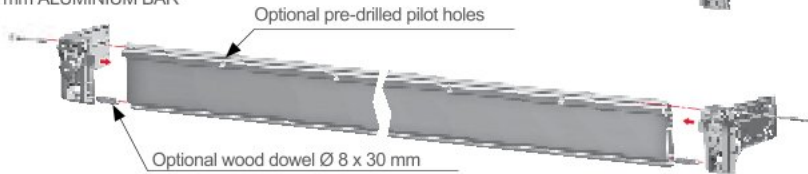

Recommended fixing self-tapping pan head screws Ø 4,2 x 45 mm.

INSTALLATION

Recommended fixing:

- insert nuts M6 x 13 mm
- flat head screws M6 x 12 mm

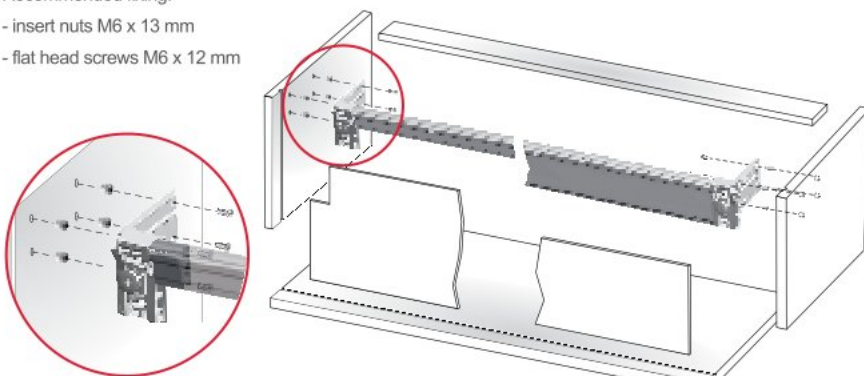

INSTALLATION ON THE WALL

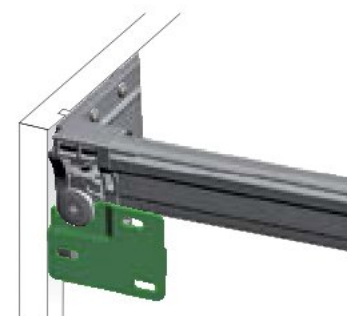

For specific information regarding the wall type and the related hardware fittings, please refer to the WARNING section at the end of the catalogue.

The hanging system is never interfering with the slides for drawers thanks to the slim side bracket wings.

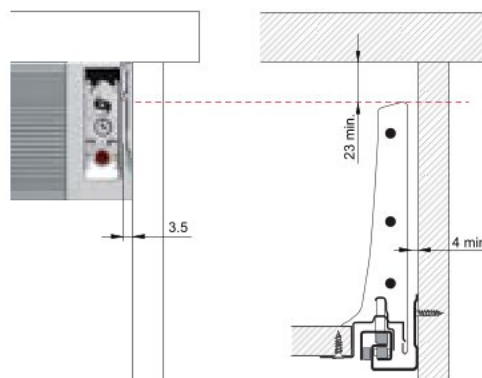

■ = STRESS INTENSITY LEVEL ON THE WALL

By adding extra hanging points on the aluminium bar, the capacity loading is more evenly distributed, thus sensibly reducing the stress intensity level on the wall.

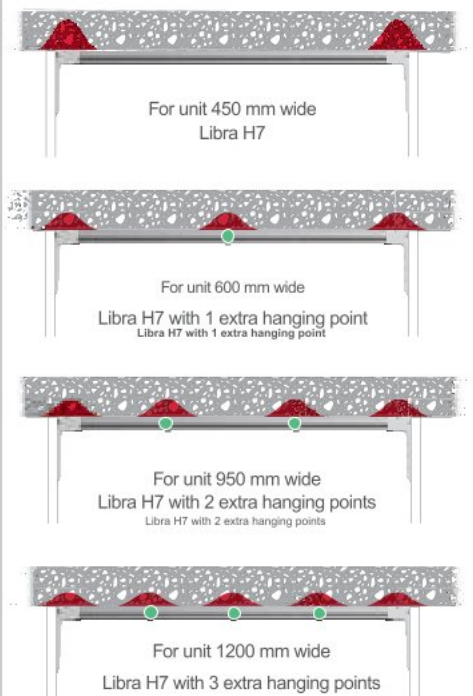

Integrato G



- Suitable to align heavy duty wardrobes, bookcases and modular furniture
- To be installed onto the bottom edge of the side carcass, wide range of zinc alloy supports available
- Adjustment to be carried out through Ø 8 mm hole in the furniture bottom by using a S6 mm allen wrench or both cross and blade screwdriver
- Zinc alloy foot provided with independent plastic glide for easier adjustment and to prevent floor scratching
- A plastic cover can be used to conceal the housing on the bottom
- **Adjustment:** 0-25 mm
- **Capacity loading:** 175 kilos each
- **Material:** Zinc alloy and plastic
- Tested according to Italian CATAS INSTITUTE requirements



1 Integrato G



2 Cover Cap

ORDERING INFORMATION

Product Description		Article No.
1	Integrato G - Zinc alloy and Black plastic	637.67.910
2	Cover Cap - White plastic	045.08.008

INSTALLATION

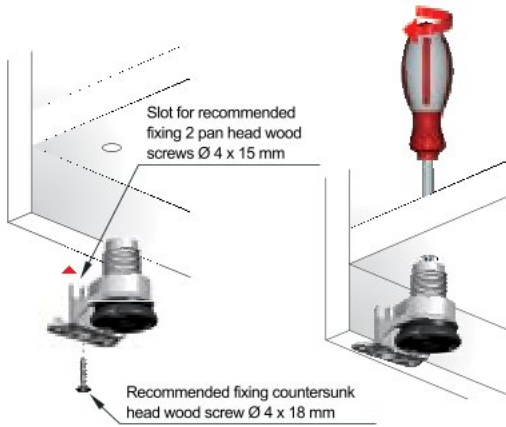

ADJUSTMENT

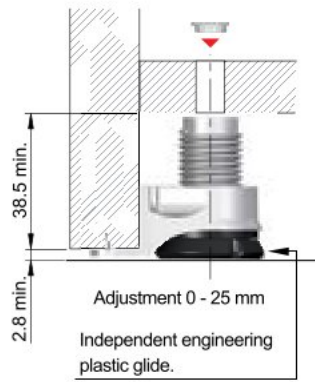

PLINTH CLIP

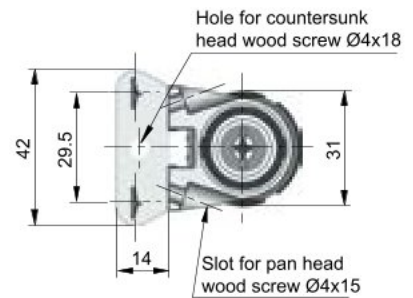
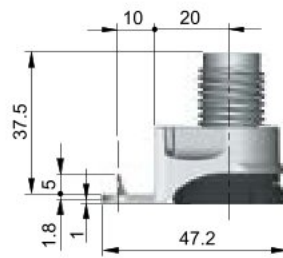
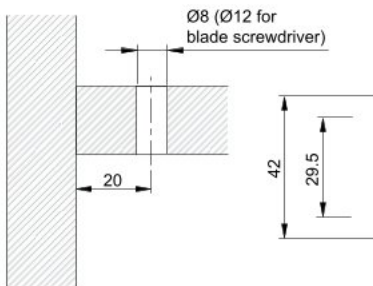
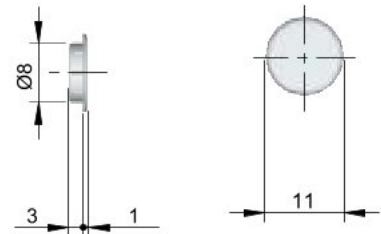
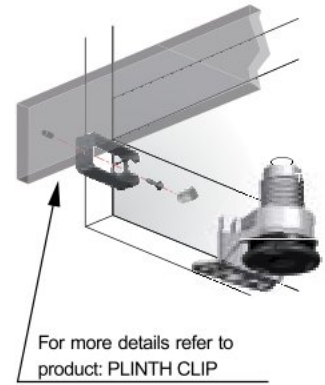

Integrato Z



- Suitable to align heavy duty wardrobes, bookcases and modular furniture with flat base furniture without skirting
- To be installed onto the bottom edge of the side carcass, wide range of zinc alloy supports available
- Adjustment to be carried out through Ø 8 mm hole in the furniture bottom by using a S6 mm allen wrench or both cross and blade screw driver
- Zinc alloy foot provided with independent plastic glide for easier adjustment and to prevent floor scratching
- A plastic cover can be used to conceal the housing on the bottom
- **Adjustment:** 7 - 17 mm
- **Capacity loading:** 175 kilos each
- **Material:** Zinc alloy and plastic
- Tested according to Italian CATAS INSTITUTE requirements



1 Integrato Z



2 Cover Cap

ORDERING INFORMATION

Product Description	Article No.
1 Integrato Z - Zinc alloy and black plastic	651.16.300
2 Cover Cap - White Plastic	045.08.008

INSTALLATION

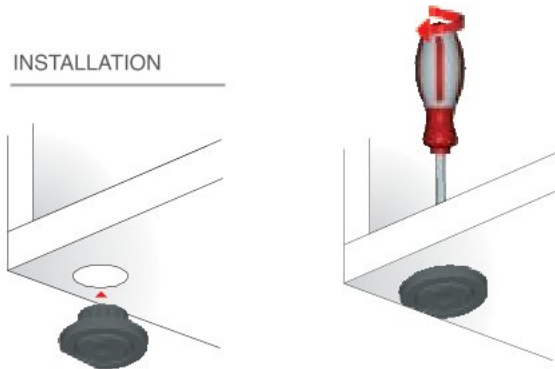

ADJUSTMENT

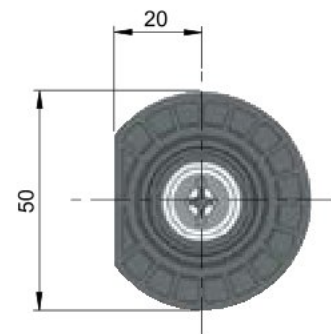
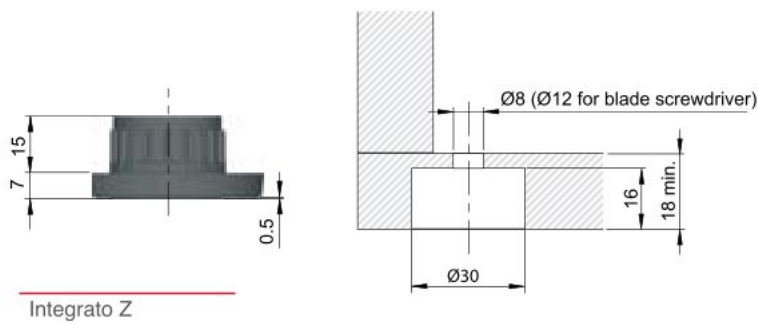
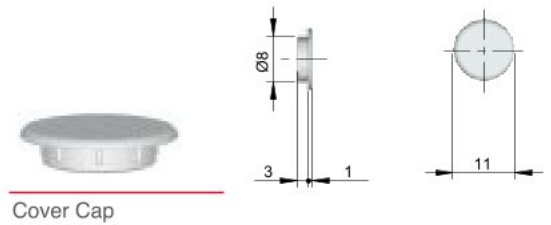
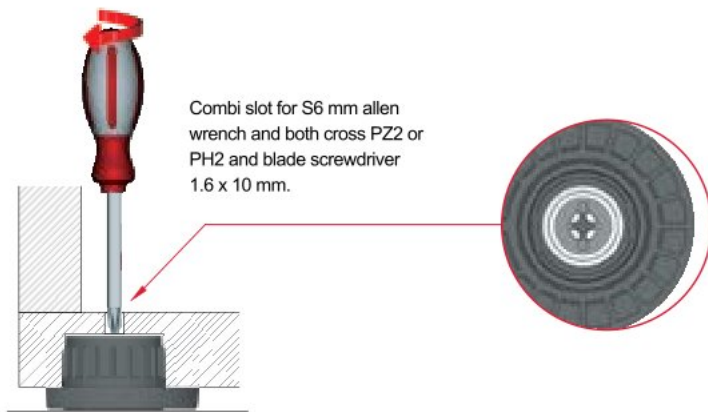
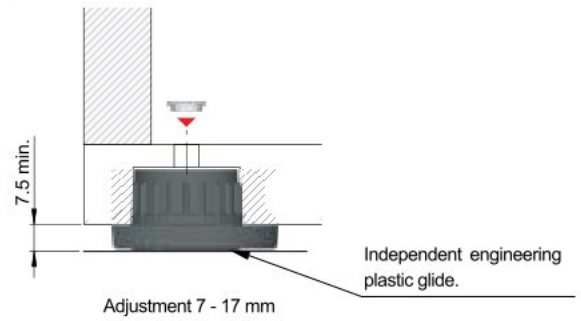

Bi-Material

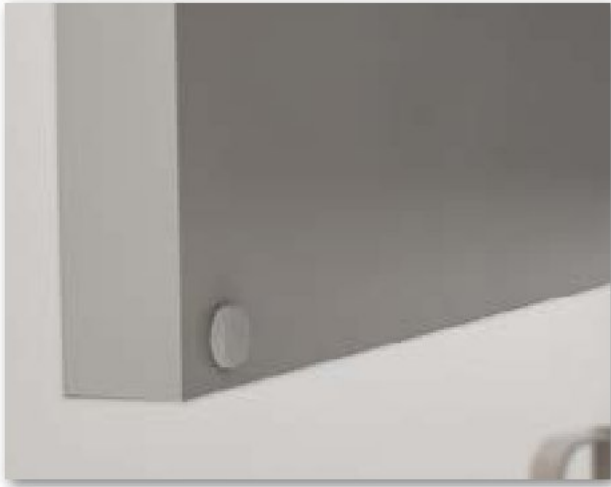

BI-MATERIAL is a unique solution to prevent cabinet doors from noisily slamming.

- A double moulded injection produces a single bumper made of two different materials: Rubber and engineering plastic.
 - a stiff pin which allows a fast installation through a $\text{Ø} 5$ mm pre-drilled hole.
 - a smooth outer surface

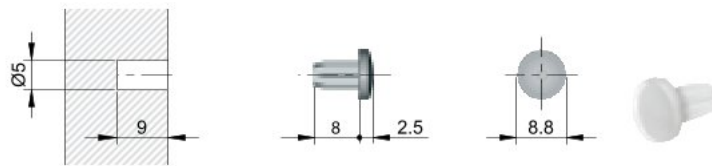

1 Bi- Material $\text{Ø} 5$ mm

The stiff part allows an easy and safe placing on the hole side, both manual and by an automatic machine.

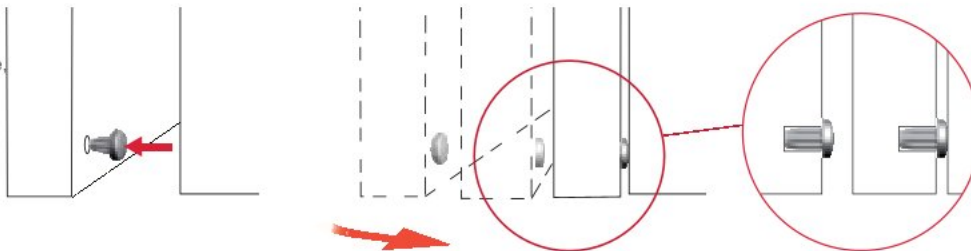

When the door closes, the impact of the door is sensibly absorbed by outer tender bumper.

ORDERING INFORMATION

Product Description	Article No.
1 Bi-Material $\text{Ø} 5$ mm - Stiff and soft rubber	356.20.423

Soft

- SOFT is the new solution to prevent cabinet doors from noisily slamming.
- A double moulded injection produces a single bumper made of two different materials: Rubber and engineering plastic.
 - a stiff pin \varnothing 10 mm with small tender windows all around and empty inside.
 - a smooth outer surface.
- In accordance with the Regulation UNI 8607/05 Level 5.

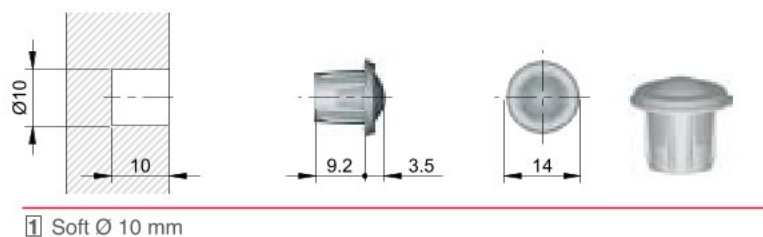

The stiff part allows an easy and safe placing on the hole side, both manual and by an automatic machine.

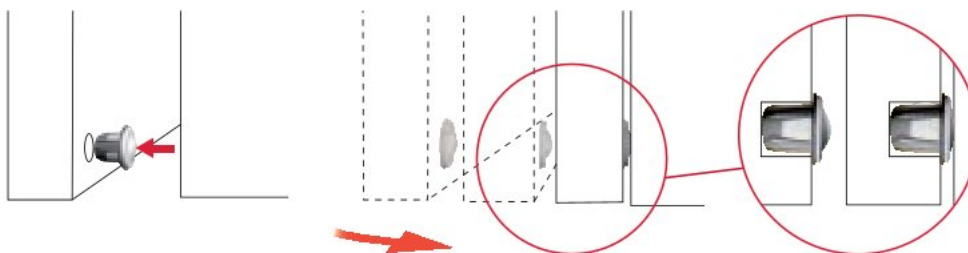

When the door closes, the impact of the door is sensibly absorbed by outer tender bumper that recedes into the empty pin and the compressed air inside of it, expands out the tender windows, thus granting a soft and silent door closure.

ORDERING INFORMATION

Product Description	Article No.
1 Soft \varnothing 10 mm - Stiff and soft rubber	356.20.521

K Lock



New magnetic system to safely keep the door closed. Suitable for unsprung and flap/piano hinges.

- **Available in 2 versions:**
 - to be installed inside the panel through a $\varnothing 10$ mm hole.
 - with adapter housing to be installed with counter sunk screws.
- Gap adjustment can be carried out through the blade screw driver by rotating the head.
- **Door plate is available:**
 - in $\varnothing 3, 5, 8$ mm
 - screw pin $\varnothing 3,5$ mm
 - self-adhesive $\varnothing 15$ mm
 - adjustable and round with screw hole
 - for curved door
- **Material:** Plastic and steel.

GAP BETWEEN CARCASE & DOOR ADJUSTMENT

INSTALLATION

To be embedded inside the panel.

Through adapter housing.

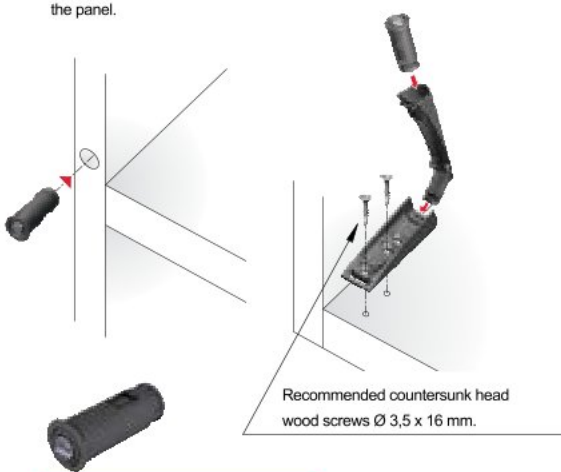

Recommended countersunk head wood screws $\varnothing 3,5 \times 16$ mm.

1 Magnet K lock - concealed

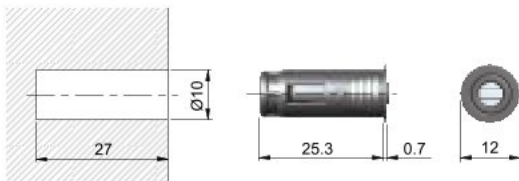

3 K lock door plates

3a With pin $\varnothing 3$ mm

3b Screw Fix

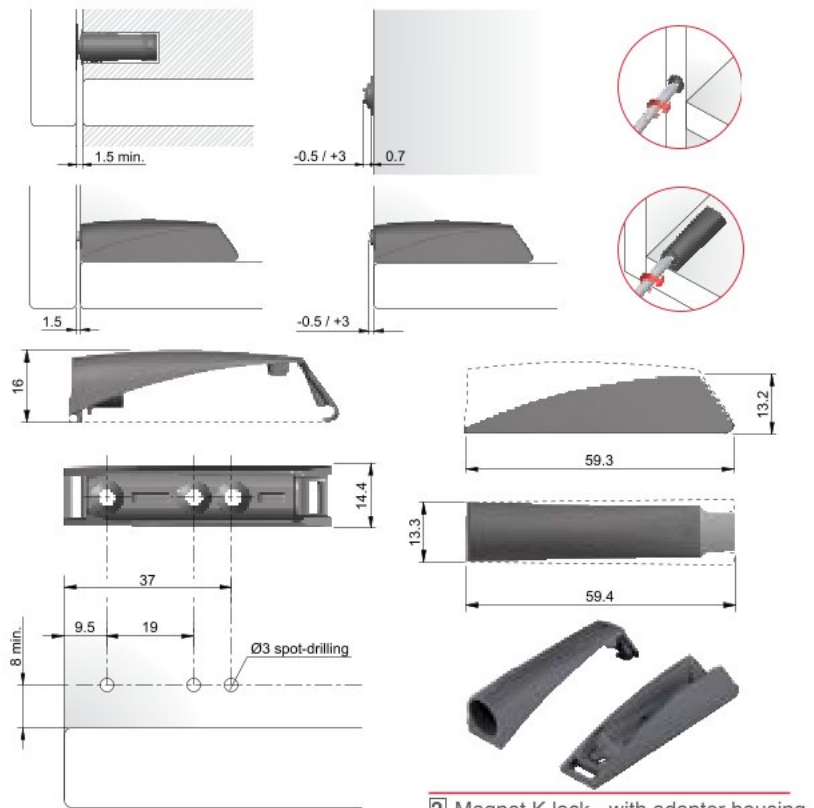

2 Magnet K lock - with adapter housing

ORDERING INFORMATION

Product Description	Article No.
1 Magnet K Lock - Concealed - Light grey plastic and steel	356.01.550
2 Magnet K Lock with Adapter Housing - Light grey plastic and steel	356.01.700
3 K Lock Door Plates	
3a K Lock Door Plates with Pin $\varnothing 3$ mm - Steel nickel plated	246.01.555
3b Screw Fix- Steel nickel plated	246.03.910

Niko

- Niko is the new Cover Cap, an essential detail to add that extra touch to your exclusive furniture.
- Made of Iron and nickel plated, Niko is an element to be simply inserted onto any $\varnothing 5$ mm hole, making the aesthetics of your furniture more innovative and captivating.
- Easily installable through machinery or by hand, Niko is sheer elegance made cover cap.

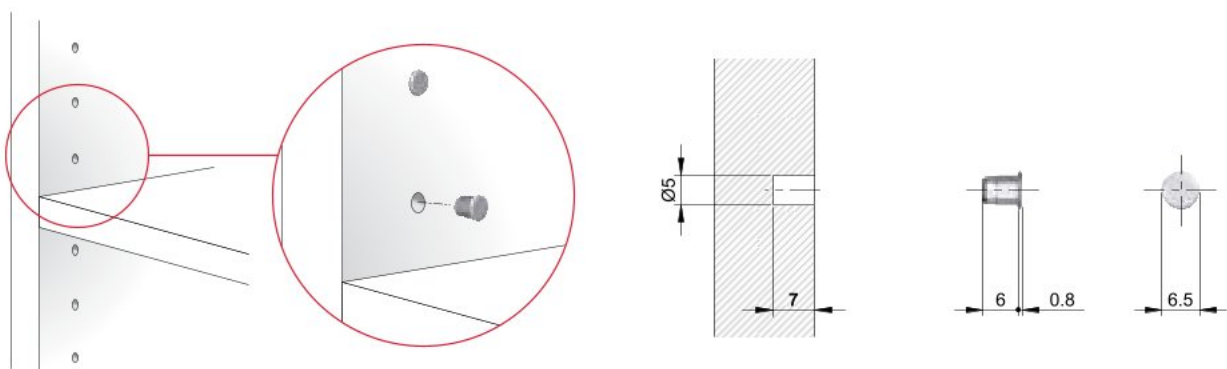

ORDERING INFORMATION

Product Description	Article No.
1 Niko $\varnothing 5$ mm - Steel nickel plated	290.21.941

K Line



Newly-designed essential and functional shelf support for both wood and glass shelves.

- Consists of a single zinc alloy element for wood shelves.
- Same element for glass shelf by simply applying a bespoke layer of rubber.
- Other version available with vertical pin to ensure wood shelf horizontal locking.
- Available with Ø 4 and Ø 5 mm pin for shelf repositioning without damaging the hole.
- In accordance with European Regulations UNI EN 14749/05.



The coloured part is in clear soft rubber



1 K Line for wood shelf



2 K Line rubber for glass shelf

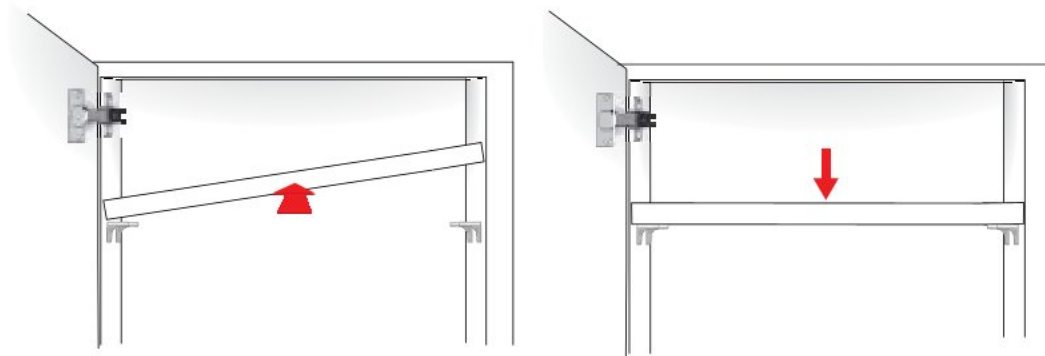

Shelf installation

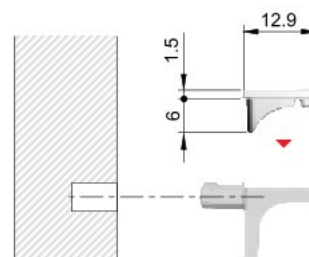
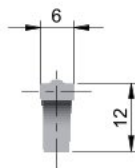
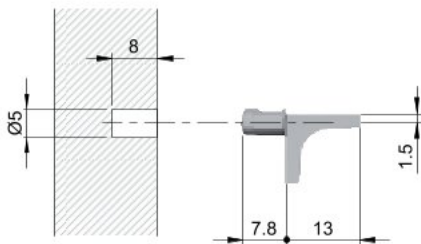

ORDERING INFORMATION

Product Description	Article No.
1 K Line for wood shelf - Nickel plated.	284.84.711
2 K Line rubber for glass shelf - Soft clear rubber	284.84.990

Flipper

Shelf support to block wood shelves minimum 14 mm thick for dispatching either flat pack or rigid furniture and for guaranteeing domestic safety.

- Load carrying capacity: 80 kg/per set of 4 pieces.
- **Consists of two separate parts:**
 - a steel dowel to be inserted onto the side panel.
 - a plastic element to be slotted into the shelf.
- Shelf is subsequently vertically pressed and clicks onto the steel dowel.
- **Steel dowel is available with:**
 - Ø 3, Ø 5 mm smooth pin and Ø 5 mm special threaded dowel for shelf repositioning without damaging the hole.
 - Ø 3 mm threaded screw or Ø 5 mm euro-threaded dowel.
 - M4 dowel for spreading dowel.
- Threaded steel dowels provide further structural function.
- In accordance with the European Regulations UNI EN 14749/05.

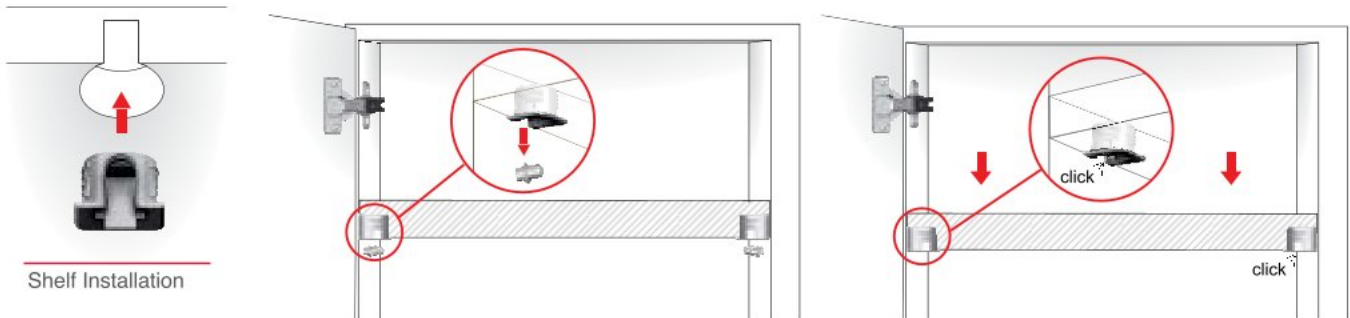

Shelf Installation



1 2 Flipper for panel 14 mm thick minimum

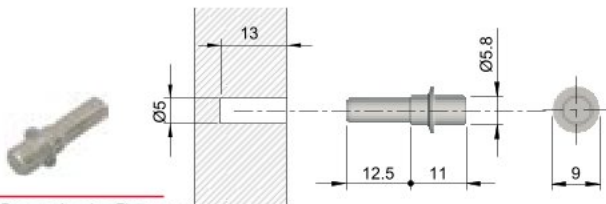
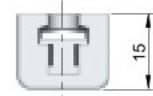
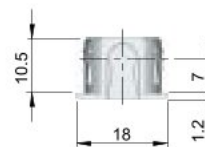
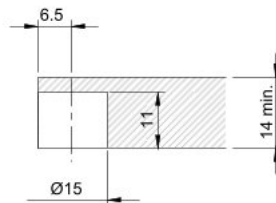

3 Smooth pin Ø 5 mm

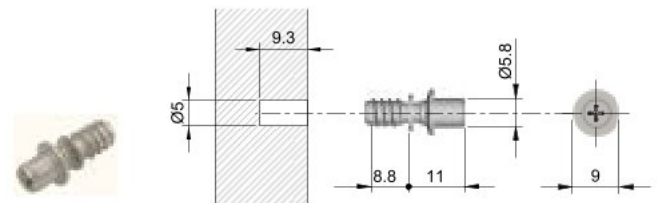

4 Euro pin to achieve horizontal connection

ORDERING INFORMATION

Product Description	Article No.
1 Flipper for panel 14 mm thick minimum - Aluminium plastic	263.07.001
2 Flipper for panel 14 mm thick minimum - White	263.07.007
3 Smooth pin Ø 5 mm - Zinc plated	263.20.004
4 Euro pin to achieve horizontal connection - Zinc Plated	263.20.002

Unico



Innovative solution to block wood shelves minimum 15 mm thick for dispatching either flat pack or rigid furniture and for guaranteeing domestic safety.

- Load carrying capacity: 80 kg/per set of 4 pieces.
- Consists of a single zinc alloy element with ridged wing on both sides that spread out when the integrated sliding plastic clip moves forward.
- Unico is supplied ready for assembly with plastic clip in the forward position.
- Shelf is subsequently vertically pressed onto the shelf support and blocked by the spread wings.
- Removal of the shelf by hand or through blade screwdriver, is carried out by sliding the plastic clip backwards.
- **Available with:**
 - Ø3 and Ø5 mm smooth pin for shelf repositioning without damaging the hole.
 - Ø3 and Ø5 mm threaded pin for further structural function.
- Unico Ø5 and Euro screw versions are in accordance with the European Regulations UNI EN 14749/05.

SHELF INSTALLATION

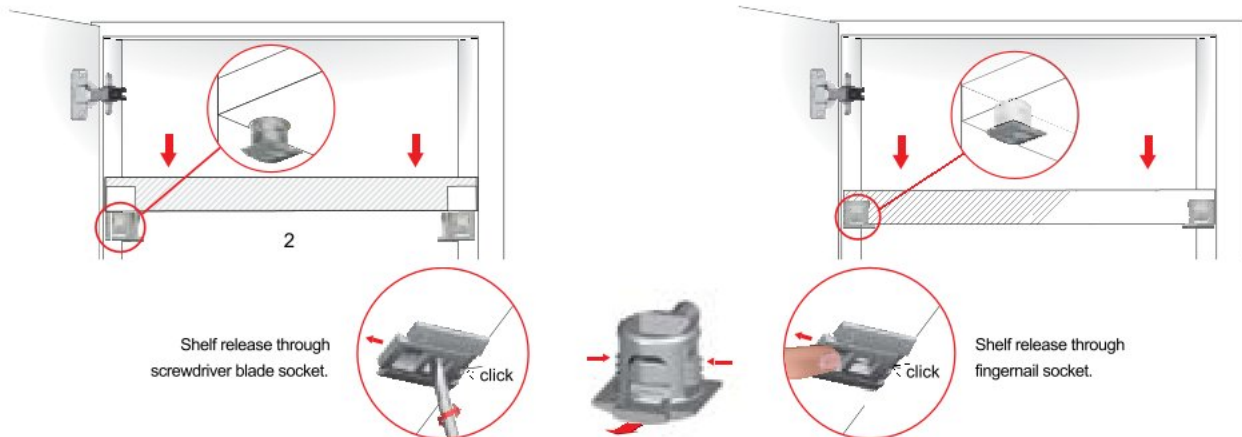

Unico for panel 15 mm thick minimum

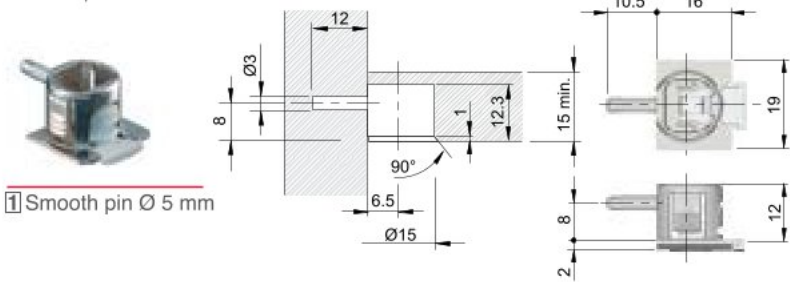

1 Smooth pin Ø 5 mm

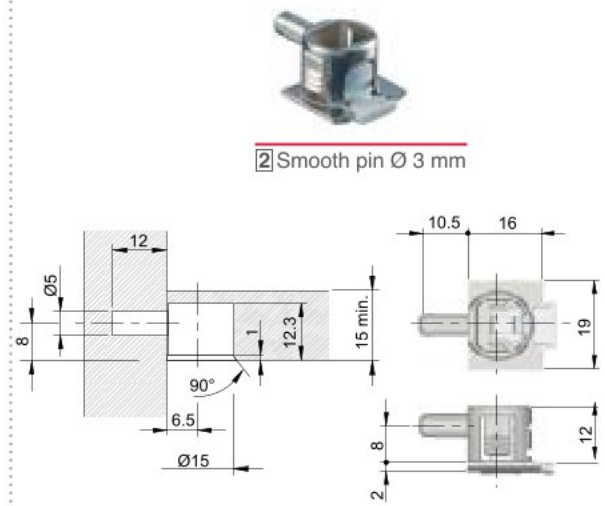

2 Smooth pin Ø 3 mm

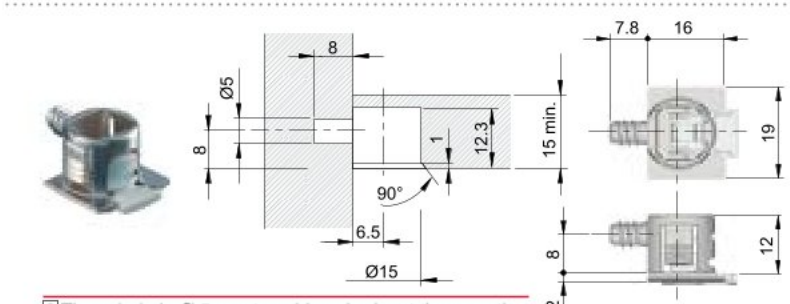

3 Threaded pin Ø 5 mm to achieve horizontal connection

ORDERING INFORMATION

Product Description	Article No.
1 Shelf Support with smooth pin Ø 5 mm - Nickel plated with grey plastic sliding clip.	262.37.700
2 Shelf Support with smooth pin Ø 3 mm - Nickel plated with grey plastic sliding clip.	262.37.710
3 Threaded pin Ø 5 mm to achieve horizontal connection - Nickel plated with grey plastic sliding clip	262.37.720

Peki

Technical shelf support to block glass shelves 4-10 mm thick for dispatching either flat pack or rigid furniture and for guaranteeing domestic safety.

- **Load carrying capacity:** 80 kg/per set of 4 pieces.
- **Consists of two zinc alloy elements:**
 - main body featuring a soft layer of rubber and the locking screw.
 - upper bracket with grooves.
- Shelf is diagonally inserted into the cabinet, upper part pushed down into the main body.
- Locking and unlocking is carried out with screwdriver, by turning 90° the locking screw.
- **Available with:**
 - Ø 3, Ø 4 and Ø 5 mm pin for shelf repositioning without damaging the hole.
- In accordance with the European Regulations UNI EN 14749/05.



SHELF INSTALLATION

SHELF LOCKING

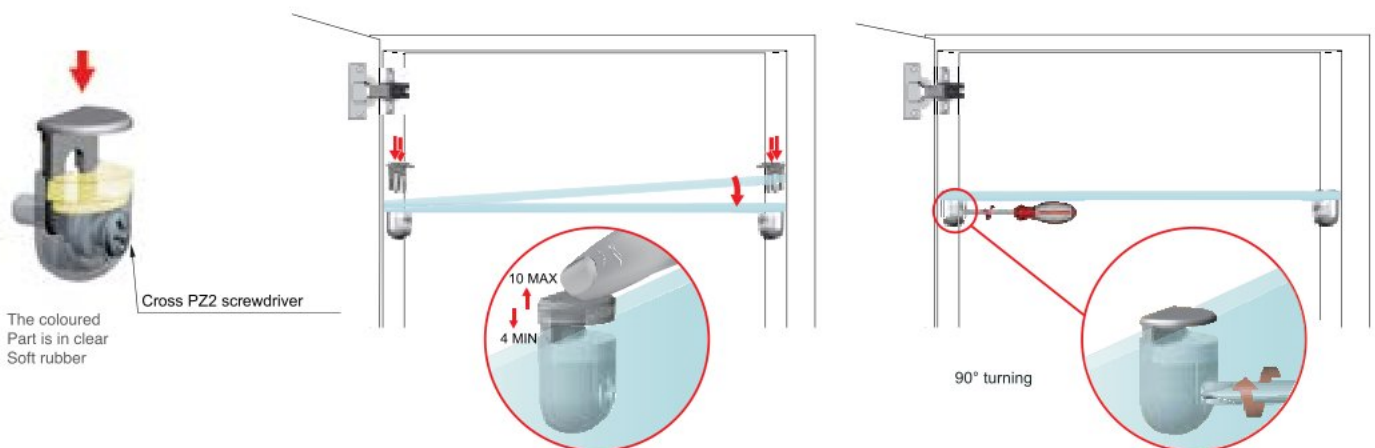

The coloured Part is in clear Soft rubber

Cross PZ2 screwdriver

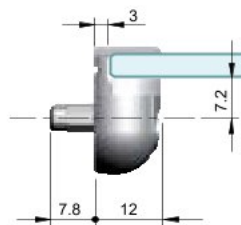
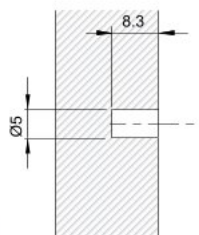

1 Peki smooth pin Ø 5 mm for glass 4-10 mm thick

ORDERING INFORMATION

Product Description	Article No.
1 Peki smooth pin Ø 5 mm for glass 4-10 mm thick - Nickel plated with locking screw.	284.04.611

Kubic



New shelf support to block glass shelves 4-8 mm thick for dispatching either flat pack or rigid furniture and for guaranteeing domestic safety.

- **Load carrying capacity:** 80 kg/per set of 4 pieces.
- **Consists of two zinc alloy elements both with soft layer of rubber:**
 - main body featuring integrated sliding locking plastic clip
 - upper part with grooves
- Shelf is diagonally inserted into the cabinet, upper part pushed down into the main body and sliding plastic clip clicked by hand upwards
- Repositioning of the shelf is carried out by clicking the sliding plastic clip downwards
- **Available with:**
 - Ø 3 and Ø 5 mm pin for shelf repositioning without damaging the hole
 - screw hole for countersunk head screw to achieve horizontal connection
- In accordance with the European Regulations UNI EN 14749/05

SHELF INSTALLATION

SHELF LOCKING

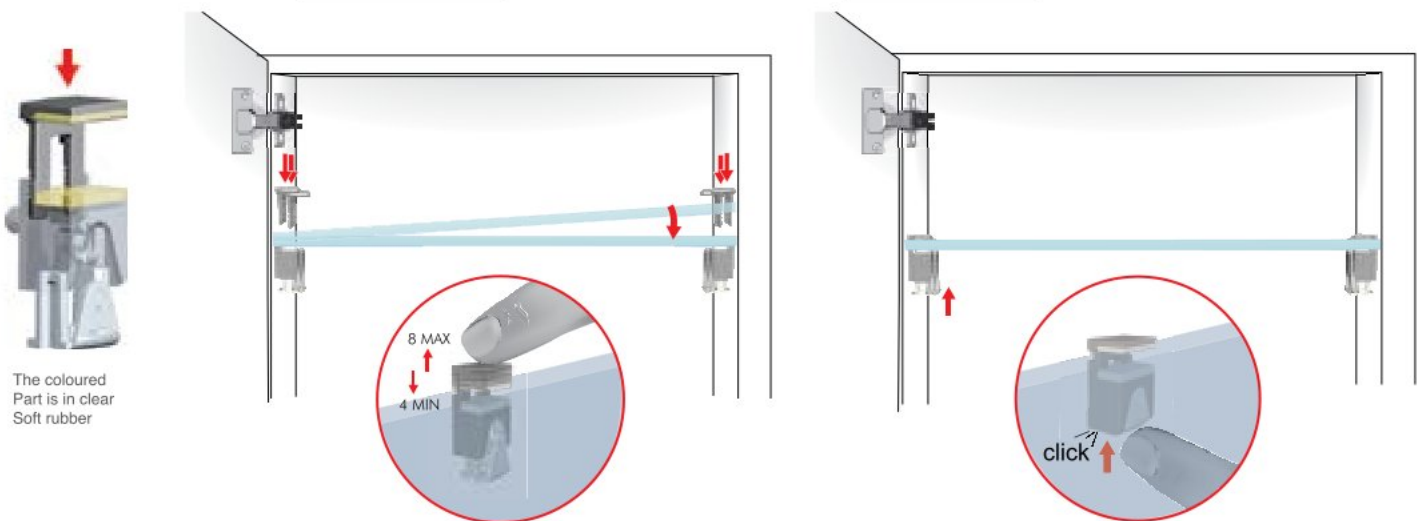

The coloured Part is in clear Soft rubber

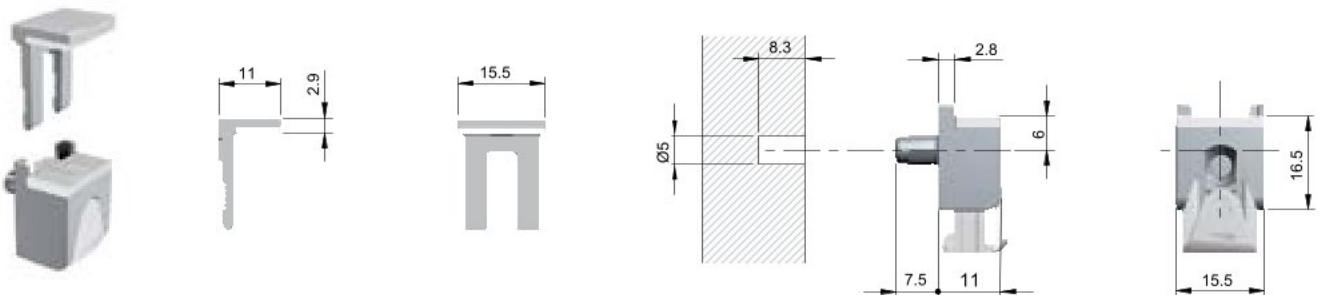

1 Kubic smooth pin Ø 5 mm for glass 4-8 mm thick

ORDERING INFORMATION

Product Description	Article No.
1 Shelf Support with Kubic smooth pin Ø 5 mm for glass 4-8 mm thick - Nickel plated with white plastic locking clip.	284.04.641

Kristal

A shelf support to block glass shelves 5-6 mm thick for dispatching either flat pack or rigid furniture and for guaranteeing domestic safety

- **Load carrying capacity:** 80 kg/per set of 4 pieces.
- **Consists of two zinc alloy elements:**
 - main body featuring a soft layer of rubber and the locking screw
 - upper bracket with grooves
- Shelf is diagonally inserted into the cabinet, upper part pushed down into the main body
- Locking and unlocking is carried out with screwdriver, by turning 90° the locking screw
- **Available with:**
 - Ø 3 and Ø 5 mm pin for shelf repositioning without damaging the hole
- In accordance with the European Regulations UNI EN 14749/05



SHELF INSTALLATION

The coloured Part is in clear Soft rubber



Metric insert in steel Cross PZ2 screwdriver

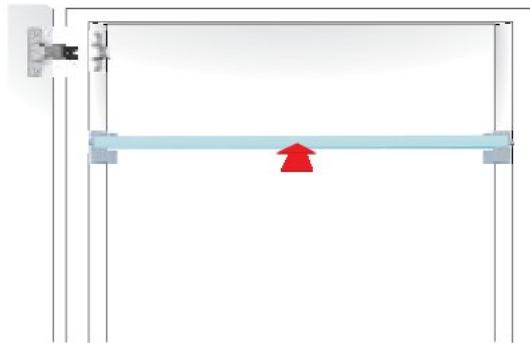

SHELF LOCKING

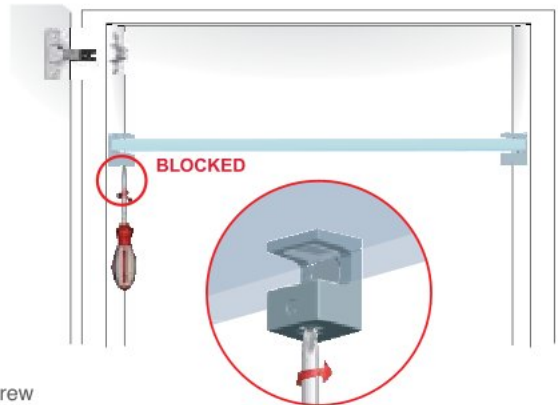

Kristal with locking metric screw



- 1 Smooth pin Ø 5 mm for glass 5-6 mm thick

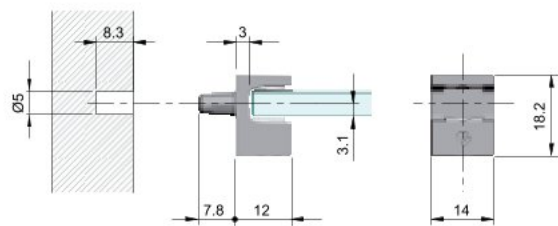

- 2 Screw hole for glass 5-6 mm thick To achieve horizontal connection.

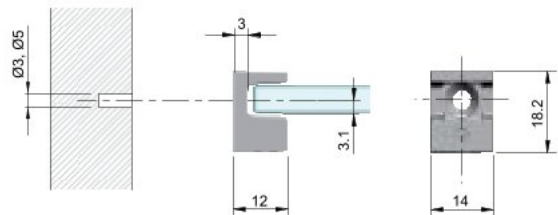

ORDERING INFORMATION

Product Description	Article No.
1 Shelf Support with smooth pin Ø 5 mm for glass 5-6 mm thick - Nickel plated	284.04.655
2 Screw hole for glass 5-6 mm thick - Chrome plated	284.04.650

Secret Maxi



Secret Maxi is the new hidden shelf support by Italiana Ferramenta, the only one that guarantees both the shelf locking and unlocking.

- **Load carrying capacity:** 60 kg/per set of 4 pieces.
- Completely hidden, even when used on bifacial furniture
- Can be used on shelves 25 mm minimum thick
- The anchoring system provides a structural junction between the shelf and the side panel, thus making Secret Maxi suitable even for constructions with flap and drop-down doors
- **Consists of:**
 - a plastic body to be inserted onto the shelf panel featuring an inner spring that moves the plastic hook out
 - a plastic socket to be inserted onto the side panel
- When flap and drop-down doors are required, the shelf can be fully locked through a Ø 4 mm hole, by turning the minifix 90° with a S2,5 mm allen wrench
- The hole for the shelf locking can be drilled on the upper or lower side of the shelf, (or even a passing through hole), according to the customer's needs
- It allows the customer to fix and remove the shelves in an easy and intuitive way. The furniture processing doesn't require any milling; simply drillings



1 Secret for panel 25 mm thick minimum



2 Side bracket

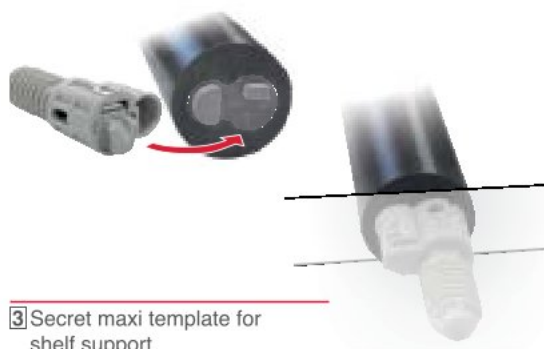

3 Secret maxi template for shelf support



4 Secret maxi template for side socket

ORDERING INFORMATION

Product Description	Article No.
1 Secret for panel 25 mm thick minimum - Light grey plastic with inner spring plastic hook.	284.03.356
2 Side bracket - Light grey plastic.	284.03.357

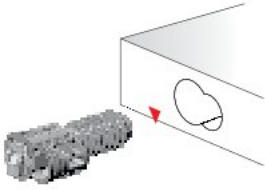

Shelf support insertion
On the shelf

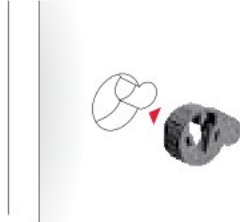

Side bush insertion

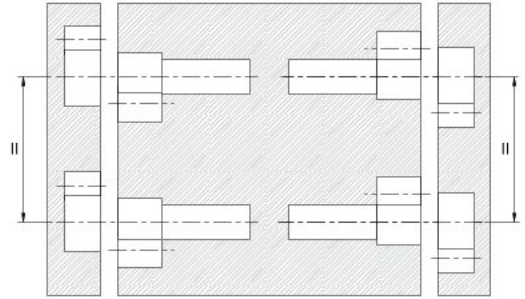

Alignment shelf support and side bush

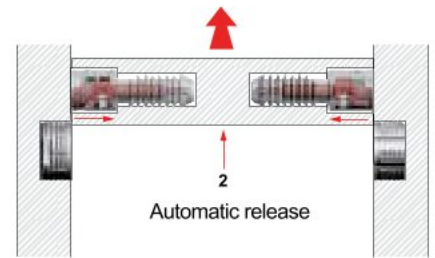
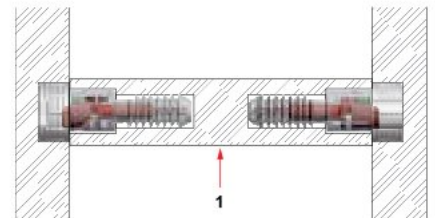
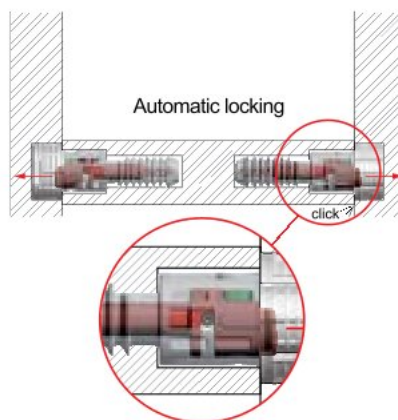
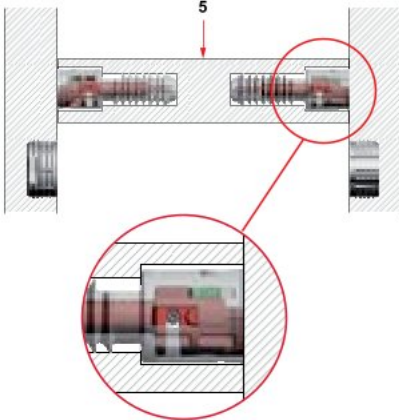
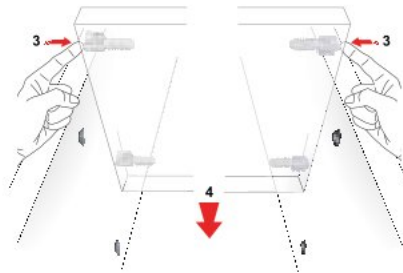
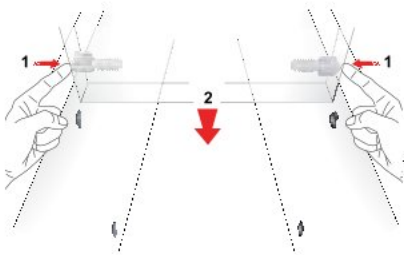

Shelf placement

Shelf removal

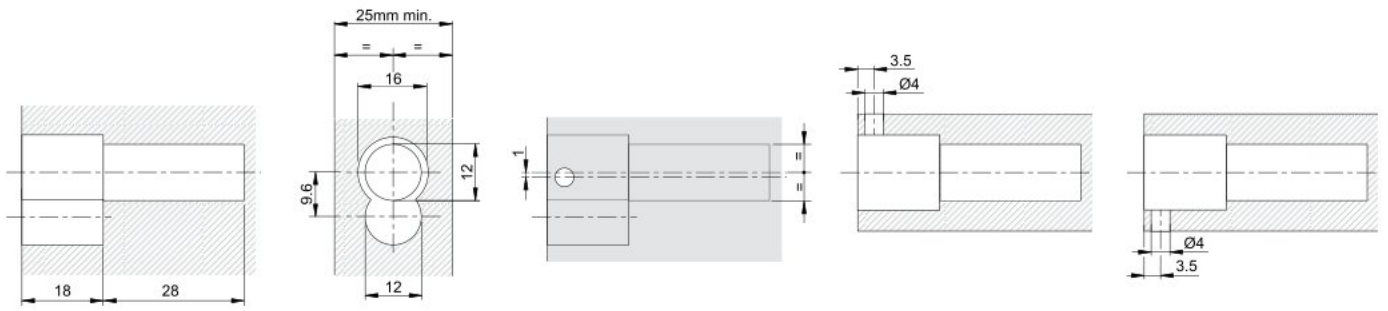

Secret for panel 25 mm thick minimum

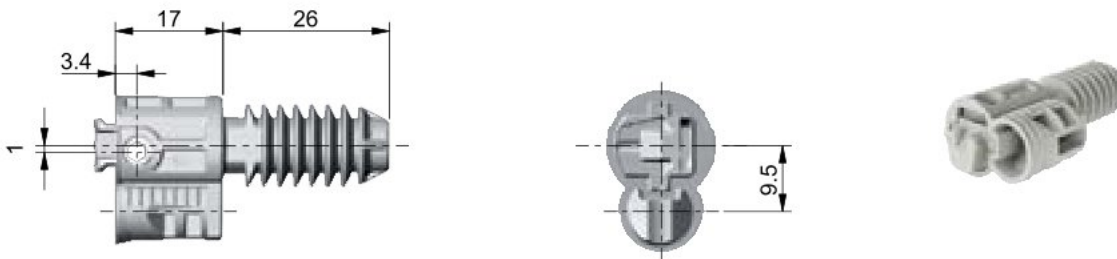

1 Secret for panel 25 mm thick minimum

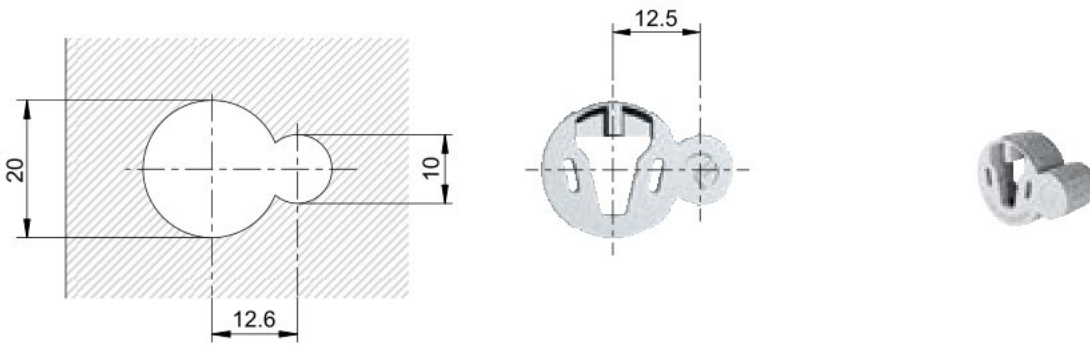

2 Side bracket

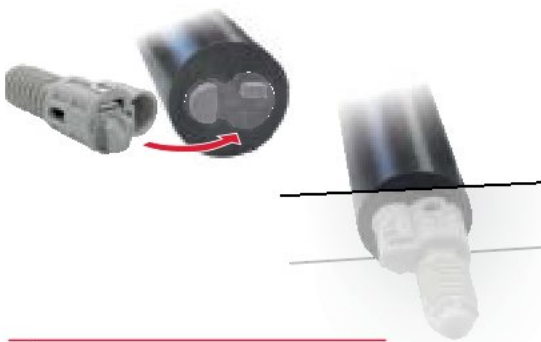

3 Secret maxi template for shelf support

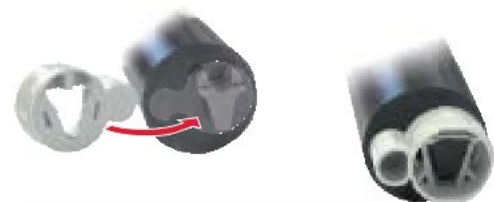

4 Secret maxi template for side socket

Kalabrone Mini

Brand new shelf support for small free-standing glass shelves.

- Fresh and contemporary design
- Suitable for glass shelves from 5 up to 10 mm thick clamped between a soft rubber on both the upper and lower side
- Easy alignment of the brackets against the wall
- White plastic cover to conceal the housing of the clamping screw
- **High capacity loading:** 6 kilos per piece (approx 12 kilos per pair), for 150 mm shelf depth
- Zinc alloy, soft rubber and plastic.

Wide range of finishes: SS, Chrome bright & Silver



INSTALLATION



KALABRONE MINI 5 - 10 mm THICK

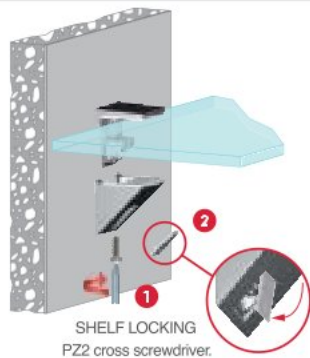

ADJUSTMENT

Bracket alignment

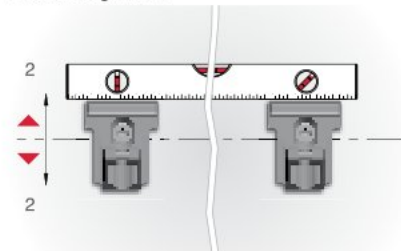

Kalabrone Mini is supplied individually bagged with fixing clamping screw, white plastic cover cap and instruction sheet.

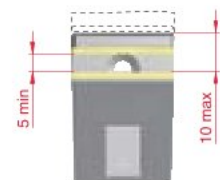
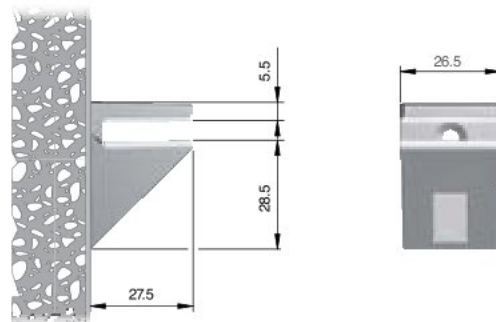

Shelf is clamped between a layer of soft rubber on both the lower and upper side (coloured parts).

COMBINATION SHELF LOAD AND SHELF DEPTH
(The figures refer to one shelf support)

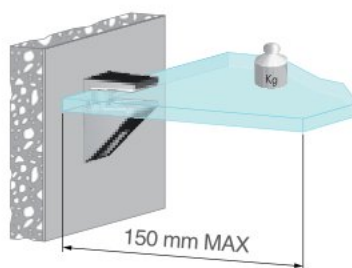
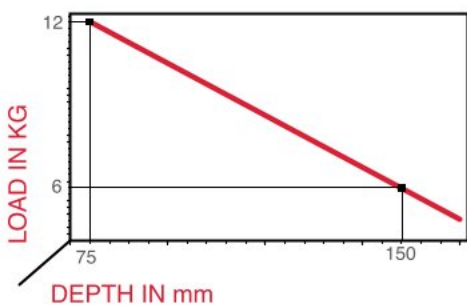

Kg + shelf weight = 6 Kg MAX for each shelf support

ORDERING INFORMATION

Product Description		Article No.
1	Kalabrone Mini - Set 1 in stainless steel	284.09.030
2	Kalabrone Mini - Set 1 in chrome bright	284.09.230
3	Kalabrone Mini - Set 1 in silver	284.09.930

Kalabrone System



- Decorative and structural shelf support for free-standing shelves
- Fresh and contemporary design, ideal for both glass and wood shelves
- **Available in two versions:**
 - Kalabrone for minimum 8 up to 30 mm thick shelves
 - Kalabrone Maxi for minimum 25 up to 50 mm thick shelves
- Recommended for honeycomb/lightweight shelves
- Shelf is clamped between a layer of ridged plastic on the lower side and soft rubber on the upper side
- Useful method for perfect and permanent alignment of the brackets against the wall
- **Features:** The unique and patented front to back angle adjustment to quickly level the shelf with a cross screw driver when the shelf is already mounted
- White plastic cover to conceal the housing of the clamping screw
- **High capacity loading:** 25 kilos per piece (approx. 50 kilos per pair), with 320 mm shelf depth
- Zinc alloy, soft rubber and plastic. Wide range of finishes

INSTALLATION

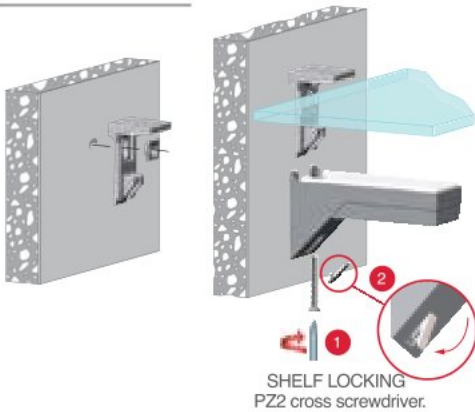

ADJUSTMENT

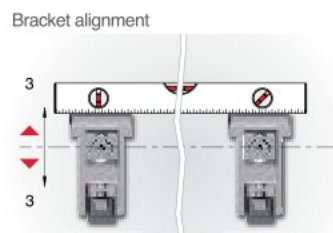

INCLINATION ADJUSTMENT

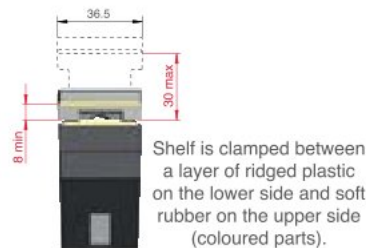
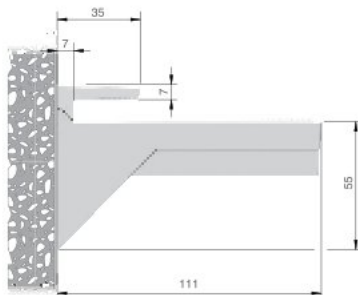
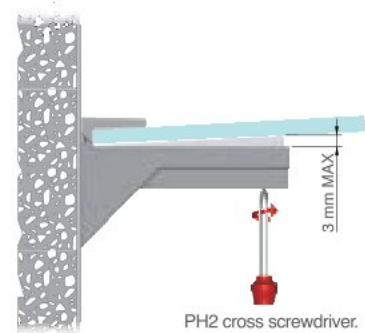

1 Kalabrone System

Combination Shelf Load And Shelf Depth (The Figures Refer To One Shelf Support)

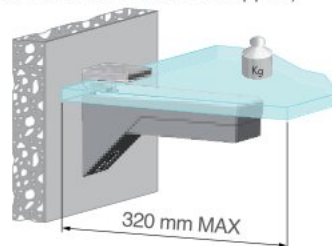
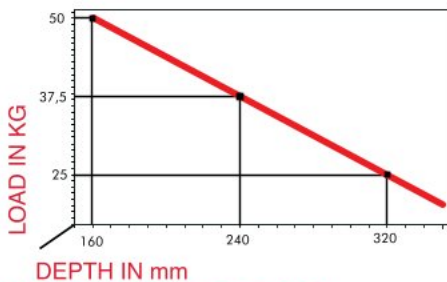

+ shelf weight = 25 Kg MAX for each shelf support

ORDERING INFORMATION

Product Description	Article No.
1 Kalabrone System - Set 1 in stainless steel	284.09.280
2 Kalabrone System - Set 1 in chrome bright	284.09.080
3 Kalabrone System - Set 1 in silver	284.09.980

Kalabrone is supplied in carton box including 2 pieces, white plastic cover caps, fixing accessories and instruction sheet. Fixing screws to wall not included.

Triade

- Concealed and structural shelf support system for free standing shelves, conceived to simplify the shelf installation
- **It is available in two versions:**
 - Triade for 30 to 40 mm thickness
 - Triade Maxi for minimum 40 mm thickness
- **Features three independent adjustments:**
 - **vertical:** for perfect alignment of the brackets against the wall
 - **lateral:** to compensate drilling leeway and to easily mount the shelf
 - **inclination:** to be carried out with an open-ended wrench key when the shelf is partially inserted. Shelf angle is adjusted front to back extremely quickly
- High capacity loading, see related charts
- Complement bracket for each Triade version to enhance the capacity loading and the shelf stability by evenly distributing the shelf load on the wall
- **Material:** Zinc alloy and steel

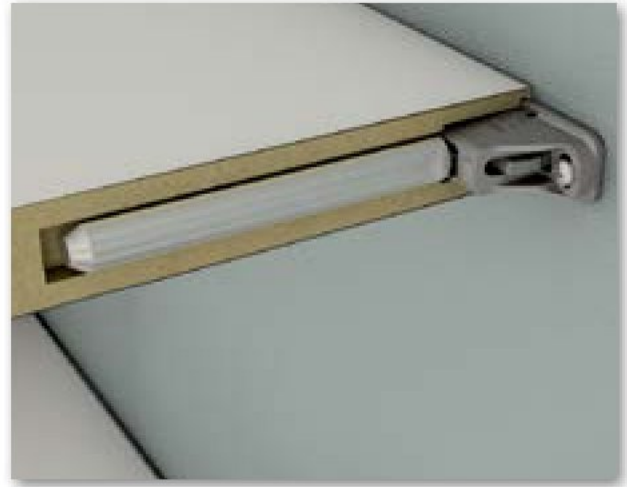

1 Triade



2 Bracket for Triade



3 Pan Head Screw

ORDERING INFORMATION

Product Description		Article No.
1	Triade - Zinc alloy and steel	283.39.010
2	Bracket for Triade - Steel zinc plated	283.39.019
3	Pan Head Screw M5 x 12 mm - Steel zinc alloy plated	013.09.008

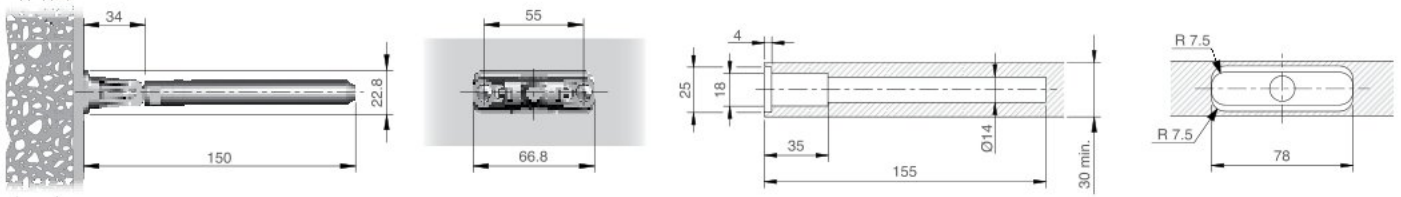

COMBINATION SHELF LOAD AND SHELF DEPTH
(The figures refer to 1 shelf support)

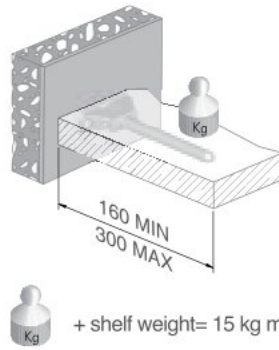
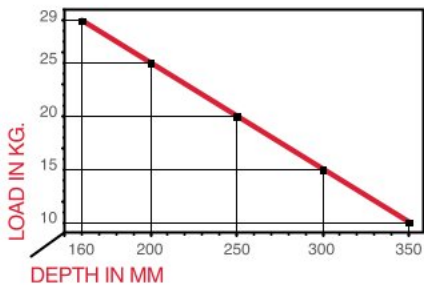

+ shelf weight= 15 kg maximum for each shelf support

BRACKET FOR TRIADE

Complement BRACKET to enhance the capacity loading and the shelf stability by evenly distributing the shelf load on the wall.

VERY IMPORTANT

Triade has to be installed with the writing "TOP-ALTO" facing upwards.

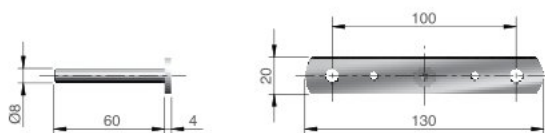
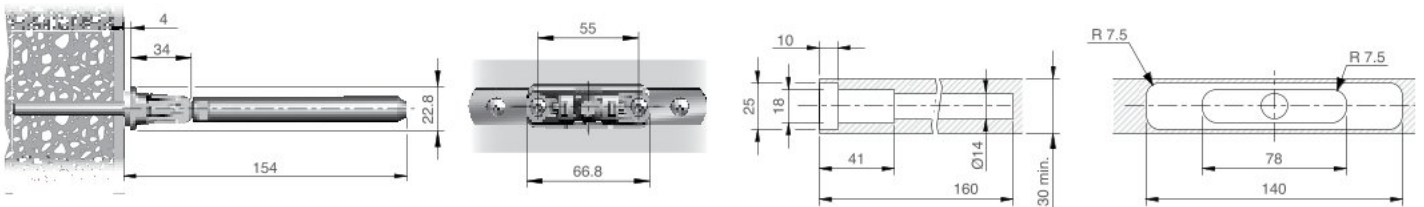
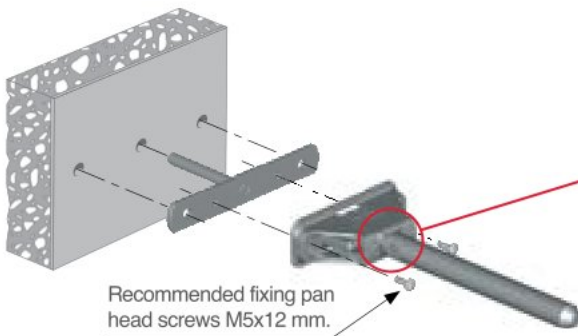

PAN HEAD SCREW M5 x 12 mm

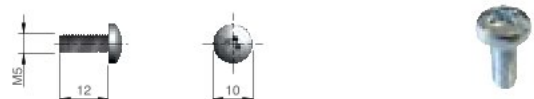

Triade Maxi

- Concealed and structural shelf support system for free standing shelves, conceived to simplify the shelf installation
- **It is available in two versions:**
 - Triade for 30 to 40 mm thickness
 - Triade Maxi for minimum 40 mm thickness
- **Features three independent adjustments:**
 - **vertical:** for perfect alignment of the brackets against the wall
 - **lateral:** to compensate drilling leeway and to easily mount the shelf
 - **inclination:** to be carried out with an open-ended wrench key when the shelf is partially inserted. Shelf angle is adjusted front to back extremely quickly
- High capacity loading, see related charts
- Complement bracket for each Triade version to enhance the capacity loading and the shelf stability by evenly distributing the shelf load on the wall
- **Material:** Zinc alloy and steel



1 Triade Maxi



2 Bracket for Triade Maxi



3 Pan Head Screw

ORDERING INFORMATION

Product Description	Article No.
1 Triade Maxi - Zinc alloy and steel	283.39.012
2 Bracket for Triade Maxi - Steel zinc plated	283.39.021
3 Pan Head Screw M5 x 12 mm- Steel zinc alloy plated	013.09.008

VERY IMPORTANT
Centre of the hole is shifted 3,5 mm upwards.
Please keep in mind when levelling the shelf.

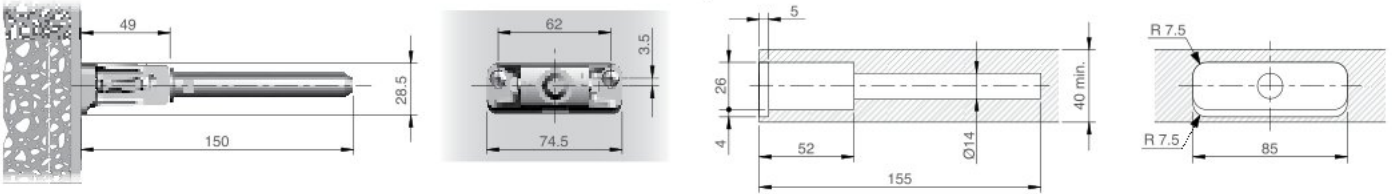

COMBINATION SHELF LOAD AND SHELF DEPTH
(The figures refer to 1 shelf support)

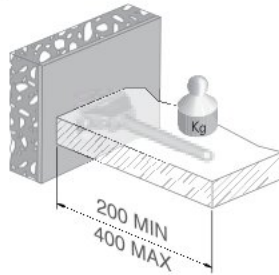
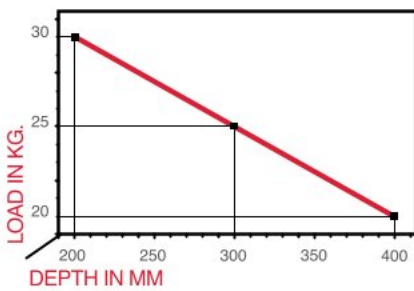

Kg + shelf weight = 20 kg maximum for each shelf support

BRACKET FOR TRIADE MAXI

Complement BRACKET to enhance the capacity loading and the shelf stability by evenly distributing the shelf load on the wall.

VERY IMPORTANT: Triade Maxi has to be installed with the writing "TOP-ALTO" facing upwards.

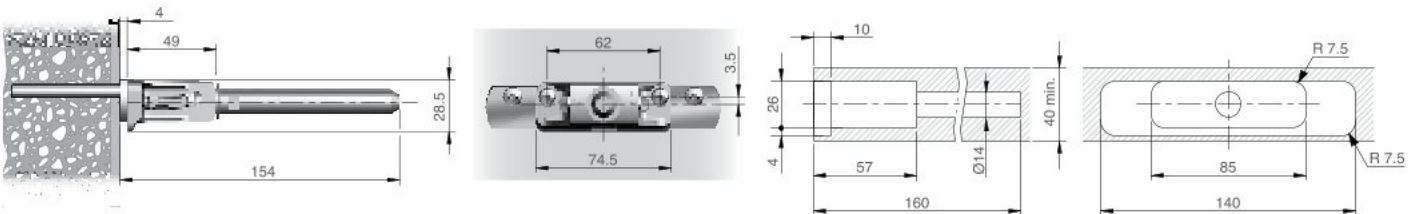
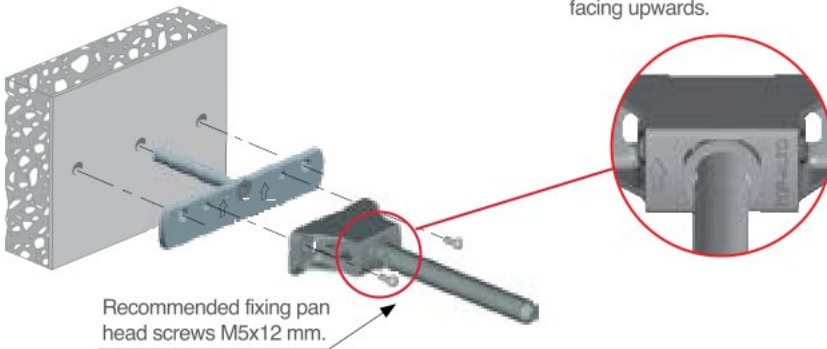

PAN HEAD SCREW M5 x 12 mm

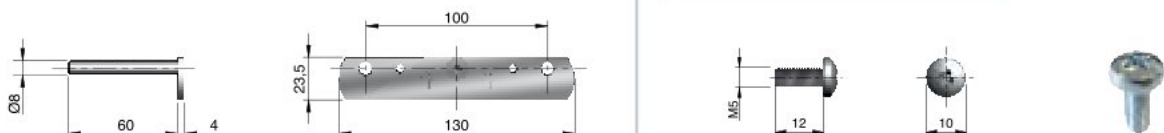

New

PLINTH FITTINGS & ACCESSORIES



Skirting Panels: Plinth Fittings Range



Häfele's New Skirting Panels from the Plinth Fittings and Accessories Range come in six different finishes unlocking multiple design possibilities and colour patterns in your kitchen. They are made of PVC which makes them light weighted and highly durable. You can cut the Skirting Panels according to your requirement and mould it to any kitchen shape with the help of our different Skirting Connectors from the range.

The Skirting Panels under Häfele's Plinth Fittings Range come in six different finishes –Dark Bronze, Graphite, Rose Gold, Gold, Silver and Aluminium Mirror. They are available in two heights of 100 mm and 150 mm.

The different finishes of the Skirting Panels are displayed below



1 Graphite



2 Rose Gold



3 Gold



4 Silver



5 Aluminium Mirror



6 Dark Bronze

ORDERING INFORMATION

	Finish	Height (mm)	Length (mm)	Thickness (mm)	Article No.
1	Graphite	100	3000	12	713.55.523
2	Rose Gold	100			713.55.423
3	Gold	100			713.55.623
4	Silver	100			713.55.923
5	Aluminium Mirror	100			713.55.823
6	Dark Bronze	100			713.55.323
7	Dark Bronze	150			713.57.323

Skirting Connectors: Plinth Fittings Range

Skirting Connectors help join two Skirting Panels and come in the same finishes as that of the Skirting Panels. The three different connectors falling in this range are the Adjustable Angle Connector, 90°Two Side Connector and 90°One Side Connector.



Note: The finish of the Skirting Panel and Skirting Connector shown in this image is for representation purposes only

1. Adjustable Angle Connector

The Adjustable Angle Connector is specifically designed for places where Skirting Panels need to be connected in an angle other than 90°. It thus blends in seamlessly with any kitchen shape enhancing its versatility. It is also used to linearly join two Skirting Panels when the length of one Skirting Panel isn't adequate.

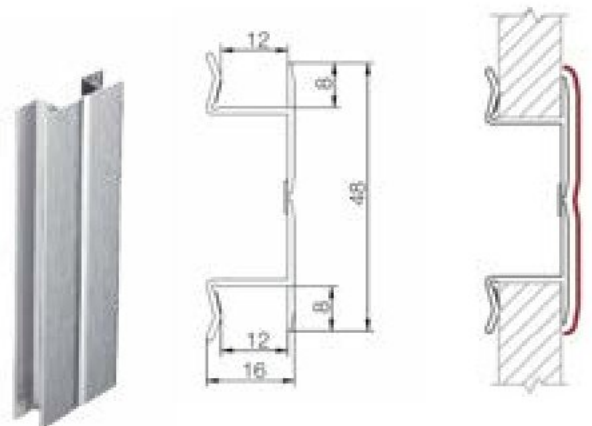

ORDERING INFORMATION

	Finish	Height (mm)	Article No.
1	Graphite	100	713.55.530
2	Rose Gold	100	713.55.430
3	Gold	100	713.55.630
4	Silver	100	713.55.230
5	Aluminium Mirror	100	713.55.830
6	Dark Bronze	100	713.55.330
7	Dark Bronze	150	713.57.330

2. 90°Two Side Connector

The 90°Two Side Connector (finish on both sides) joins two Skirting Panels at a standard right angle.

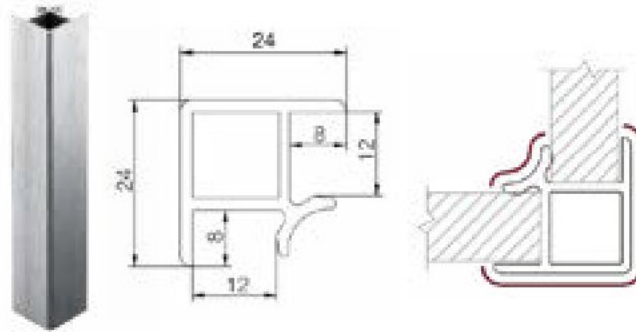

ORDERING INFORMATION

	Finish	Height (mm)	Article No.
1	Graphite	100	713.55.560
2	Rose Gold	100	713.55.460
3	Gold	100	713.55.660
4	Silver	100	713.55.960
6	Dark Bronze	100	713.55.360
7	Dark Bronze	150	713.57.360

3. 90°One Side Connector

The 90°One Side Connector (finish on the outer side) joins two Skirting Panels at a standard right angle and is only available in the Aluminium Mirror finish.

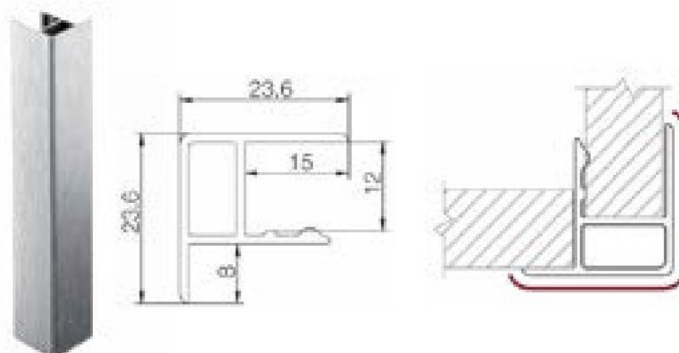

ORDERING INFORMATION

	Finish	Height (mm)	Article No.
1	Aluminium Mirror	100	713.55.861

Plinth Legs and Connectors

Plinth Legs: Plinth Fittings Range

Plinth Leg for Triangular Base

Plinth Legs from Häfele's Range of Plinth Fittings are the blocks that hold the kitchen cabinetry in place and provide support to your Skirting. All Plinth Legs in this range have a weight carrying capacity of 200 kg/leg and are made out of thermo plastic which has a high shock resistance. They also demonstrate excellent dimensional stability and durability overtime, and ensure high mechanical and chemical resistance.

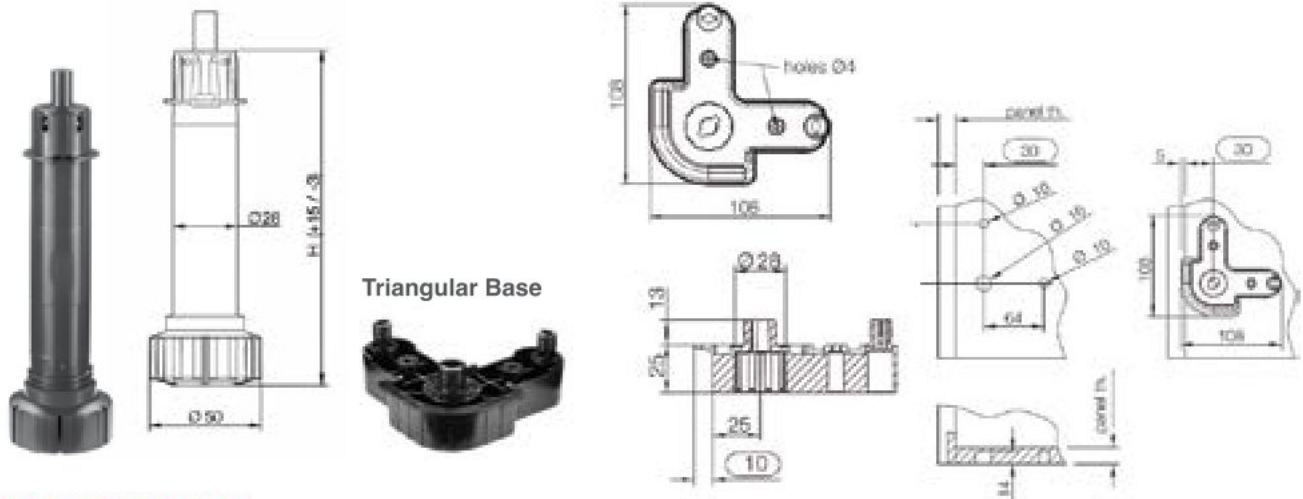

ORDERING INFORMATION

Product Description	Height (mm)	Material	Finish	Article No.
1 Plinth Leg for Triangular Base	100	Thermoplastic	Black	637.87.322
2 Plinth Leg for Triangular Base	150			637.87.324
3 Triangular Base				637.87.340

Plinth Leg with Triangular Base offers extra support to your carcass and cabinetry owing to its structure and installation.

Plinth Leg with Round Base

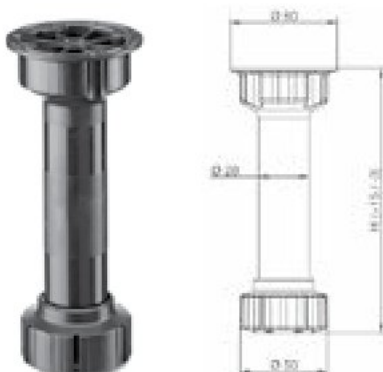

ORDERING INFORMATION

Product Description	Height (mm)	Material	Finish	Weight Bearing Capacity	Article No.
1 Plinth Leg with Round Base	100	Thermoplastic	Black	400 kg / leg	637.29.751
2 Plinth Leg with Round Base	150				637.29.730

Plinth Connectors: Plinth Fittings Range



The Blink Connector provides you access to the space below the kitchen cabinetry without much effort. It connects the Skirting Panel to the Plinth Leg and holds it in place. The plastic insert of the Blink Connector houses a magnetic disc; this plastic insert gets locked in the groove of the Skirting Panel and the magnetic disc attaches itself to the metal plinth clip which is fastened around the plinth leg. This solution also makes detaching your Skirting Panel easy.

Blink Connector Set



Magnetic disc housing

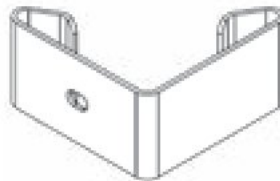

Metal plinth clip

ORDERING INFORMATION

Product Description	Material	Finish	Article No.
1 Blink Connector Set	Metal (Plinth Clip), Magnet (Magnetic Disc), Plastic (Housing)	Silver, Red	637.27.384

Standard Clip

The Standard Clip attaches the Skirting Panel to the Plinth Leg with the help of its clasp like structure thus providing a firm hold for the connection.

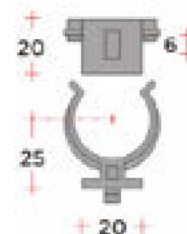

ORDERING INFORMATION

Product Description	Material	Finish	Article No.
1 Standard Clip	Plastic	Black	637.87.330

Ventilation Grill

The Ventilation Grills within Häfele's Plinth Fittings Range enable air circulation inside the built-in cabinets of your kitchen which lets your built-in appliances work efficiently at their optimum level for a longer period of time. The Ventilation Grill comes in finishes similar to your Skirting Panels, blending in excellently with your kitchen base.

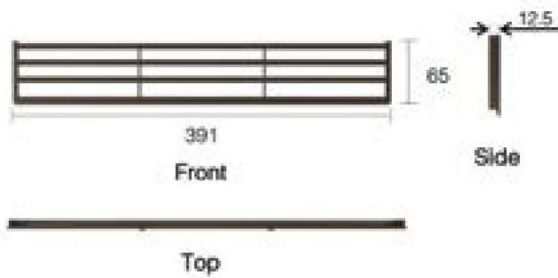

The different finishes of the Ventilation Grill are displayed below.

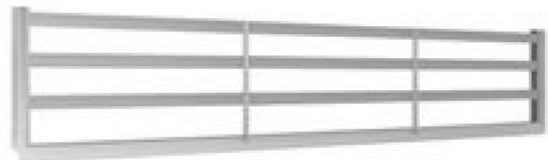
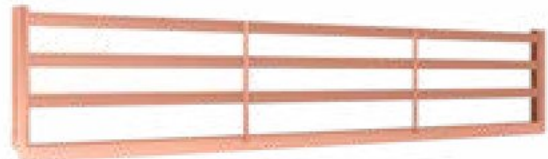
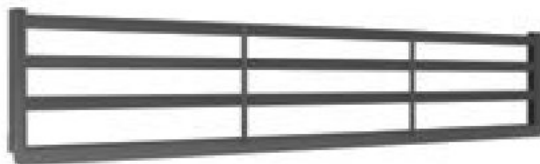

ORDERING INFORMATION

	Finish	Width (mm)	Height (mm)	Thickness (mm)	Article No.
1	Graphite	391	65	12.5	571.83.300
2	Rose Gold				571.83.000
3	Gold				571.83.800
4	Silver				571.83.900
5	Dark Bronze				571.83.100

LIGHTING SOLUTIONS





Loox5

Colour codes.



Intu
con



24

Green-in-green
The Loox5 system with
24 volts

Monochrome
RGB
Multi-white

itive
_ _ nec _ _ tions.

Cabinet Downlights - Surface Mounted

12 V SYSTEM



Specifications

- Uniform lighting
- Dimmable
- **Installation:** For screw fixing
- **Family name:** 2027

Supplied with

- 1 light with 2 m lead and fixing material

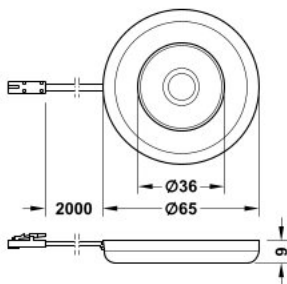

3000 K	4000 K	5000 K	117°
867 lx	884 lx	918 lx	250 mm
216 lx	221 lx	229 lx	500 mm
96 lx	98 lx	102 lx	750 mm
54 lx	55 lx	57 lx	1000 mm



LED Driver
833.74.960

Constant Voltage 12 V DC, Input - 100-240 V, Max 1.25 A, 0-20 Watts, 6 slots for 12 V lights, 1 slot for a switch (integrated switching function), 1 slot for mains plug.

Can drive upto 6 lights

ORDERING INFORMATION

	Ø (mm)	Height (mm)	Wattage (W)	Finish	Colour temp.	Article No.
1	65	9	2.6	Aluminium, silver coloured anodized, plastic	3000 K (Warm White)	833.72.050
2	65	9	2.6	Aluminium, silver coloured anodized, plastic	4000 K (Natural White)	833.72.051
3	65	9	2.6	Aluminium, silver coloured anodized, plastic	5000 K (Cool White)	833.72.052

Recess/ Surface Mounted Downlight, Round

12 V SYSTEM

Specifications

- Modular fitment comes with different recess & surface mounting options
- IP44 when Recess
- Dimmable
- **Drill hole Ø:** 26 mm
- **Installation:** For mounting in drilled hole, with clip fastener or for screw fixing
- **Family name:** 2022

Supplied with

- 1 light with 2 m lead



3000 K	4000 K	5000 K	90°
650 lx	650 lx	650 lx	250 mm
163 lx	163 lx	163 lx	500 mm
72 lx	72 lx	72 lx	750 mm
40 lx	40 lx	40 lx	1000 mm

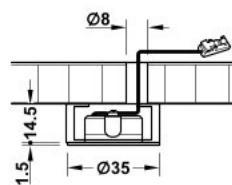
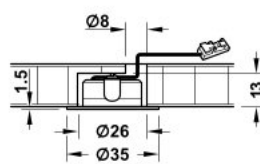
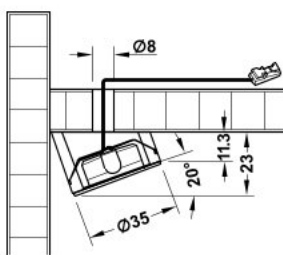

LED Driver
833.74.960

Constant Voltage 12 V DC, Input - 100-240 V, Max 1.25 A, 0-20 Watts, 6 slots for 12 V lights, 1 slot for a switch (integrated switching function), 1 slot for mains plug.

Can drive upto 6 lights

 Housing for surface mounting, silver col.
> Round Art. No. 833.72.831

 > Angular Art. No. 833.72.832

ORDERING INFORMATION

	Ø (mm)	Height (mm)	Wattage (W)	Finish	Colour	Colour temp.	Article No.
1	35	14	1.5	Aluminium	Silver plated polished	3000 K (Warm White)	833.72.040
2	35	14	1.5	Aluminium	Silver plated polished	4000 K (Natural White)	833.72.041
3	35	14	1.5	Aluminium	Silver plated polished	5000 K (Cool White)	833.72.042



Recess/Surface Mounted Downlights

Monochrome, drill hole Ø: 55 mm



12 V SYSTEM



Specifications

- **Dimmable:** Yes
- **Material:** Steel
- **Finish:** Polished chrome plated
- **Energy efficiency class:** A+
- **Degree of protection:** IP20
- **Mounting:** For mounting in drilled hole, for clamp fixing or for screw fixing
- **Family name:** 2047
- **Drill hole Ø:** 55 mm

Supplied with

- 1 light with 2 m lead



3000 K	4000 K	5000 K	120°	
560 lx	570 lx	670 lx		250 mm
210 lx	215 lx	245 lx		500 mm
115 lx	115 lx	135 lx		750 mm
75 lx	75 lx	90 lx		1000 mm

LED 2047

Downlight housing



> Surface mounted housing, steel

Colour	Article. No.
Stainless steel coloured	833.72.804
Silver coloured	833.72.803
Polished chrome plated	833.72.802

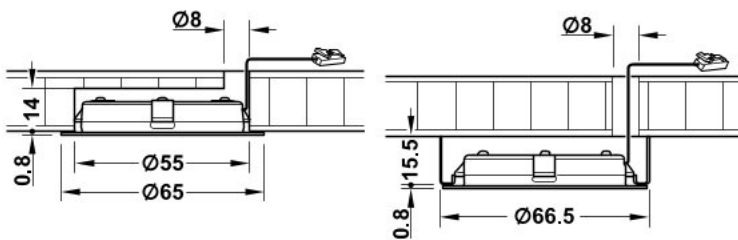

Recess mounting

Mounting as downlight



LED Driver 833.74.960

Constant Voltage 12 V DC, Input - 100-240 V, Max 1.25 A, 0-20 Watts, 6 slots for 12 V lights, 1 slot for a switch (integrated switching function), 1 slot for mains plug.

Can drive upto 6 lights

ORDERING INFORMATION

Voltage	Number of LEDs	Colour temperature	Wattage	Luminous flux	Luminous efficacy	Colour rendering index CRI	Stainless steel coloured	Silver coloured	Polished chrome plated
V	LEDs	K	W	lm	lm/W	R _a			
Häfele Loox5 LED 2047									
5 12V	24	3000	3	210	70	90	833.72.390	833.72.340	833.72.300
		4000	3	216	72	90	833.72.391	833.72.341	833.72.301
		5000	3	240	80	83	833.72.392	833.72.342	833.72.302

Recess / Surface Mounted Under Cabinet Downlights with Sensors

12 V SYSTEM 24 V SYSTEM

- **Dimmable:** Yes, via Häfele Connect Mesh
- **Material:** Steel
- **Finish:** Silver coloured, Polished chrome plated
- **Energy efficiency class:** A+
- **Degree of protection:** IP20
- **Mounting:** For mounting in drilled hole, for clamp fixing or for screw fixing
- **Drill hole Ø:** 55 mm
- **Family name:** 2048/30391

Supplied with

- 1 light with 2 m multi-white lead

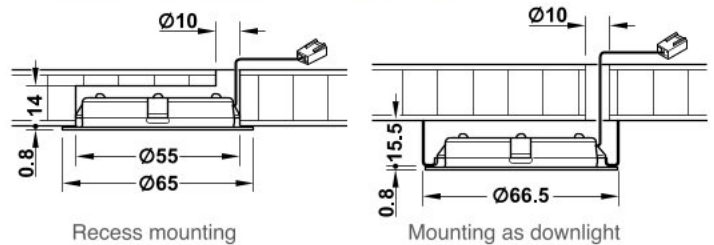

2700 K	5000 K	120°	
290 lx	345 lx		250 mm
110 lx	130 lx		500 mm
60 lx	70 lx		750 mm
40 lx	45 lx		1000 mm

LED 2048

2700 K	5000 K	120°	
335 lx	350 lx		250 mm
125 lx	130 lx		500 mm
70 lx	70 lx		750 mm
45 lx	45 lx		1000 mm

LED 3039

+ Downlight housing

Colour	Article No.
Silver coloured	833.72.803
Polished chrome plated	833.72.802

Accessories are required for controlling multi-white lights. Please order separately, see page 314.



LED Driver

833.74.960

Constant Voltage 12 V DC, Input - 100-240 V, Max 1.25 A, 0-20 Watts, 6 slots for 12 V lights, 1 slot for a switch (integrated switching function), 1 slot for mains plug.



LED Driver

833.77.945

Constant Voltage 24 V DC, Input - 100-240 V, Max 0.83 A, 0-20 Watts, 6 slots for 24 V lights, 1 slot for a switch (integrated switching function), 1 slot for mains plug.

ORDERING INFORMATION

Voltage	Number of LEDs	Colour temperature	Wattage	Luminous flux	Luminous efficacy	Colour rendering index CRI R _a	Weighted energy consumption kWh/1000 h	Silver coloured	Polished chrome plated
V	LEDs	K	W	lm	lm/W	R _a	kWh/1000 h		
Häfele Loox LED 2048									
12V	60	2700 - 5000	3	255	85	90 / 83	3.3	833.72.311	833.72.310

Recess Mounted Plinth Light Sensor Control

12 V SYSTEM



Specifications

- Recess mounted
- With integrated day light and motion sensor (If residual brightness is 15 lux or less)
- Delay time approx. 2 mins
- Drill hole Ø: 40 mm
- Family name: 2028
- Sensor range: 0-3000 mm

Supplied with

- 1 light with 2 mm lead and fixing material

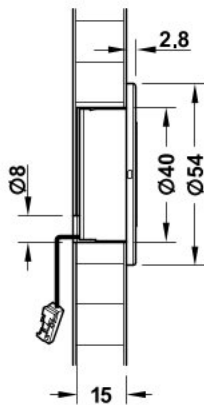
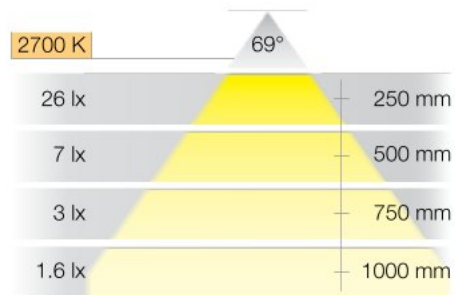

**LED Driver
833.74.960**

Constant Voltage 12 V DC, Input - 100-240 V, Max 1.25 A, 0-20 Watts, 6 slots for 12 V lights, 1 slot for a switch (integrated switching function), 1 slot for mains plug.

ORDERING INFORMATION

	Ø (mm)	Height (mm)	Wattage (W)	Light Colour	Article No.
1	54	17.3	0.34	2700 K (Warm White)	833.73.111

LED Strip Lights

Monochrome, 8 mm

Häfele Loox5 LED 3041

EXTRA NARROW 5 mm



LED 3041

Illuminance value in lx applies to 1 m strip length:

2700 K	3000 K	4000 K	5000 K	120°	
1860 lx	1960 lx	2000 lx	2060 lx		250 mm
790 lx	850 lx	860 lx	860 lx		500 mm
440 lx	470 lx	480 lx	480 lx		750 mm
270 lx	290 lx	290 lx	290 lx		1000 mm

LED 3041

Equipped with high-quality Samsung LEDs

- **Dimmable:** Yes
- **Material:** Plastic
- **Finish/colour:** White
- **Width:** 5 mm
- **Height:** 1.3 mm
- **Life time L80/B10:** >50,000 h
- **Degree of protection:** IP20
- **Mounting:** Self-adhesive
- **Supplied with:** 1 roll

Order reference: Please order lead separately.

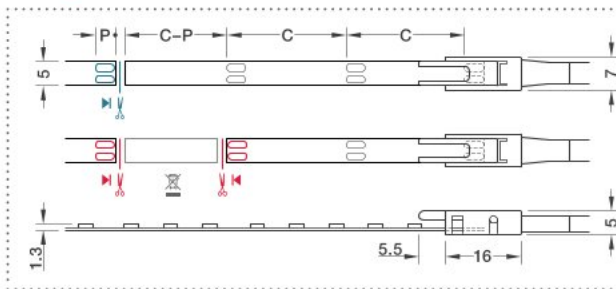

- Cut LED strip light to length (one contact side remains with the offcut; can be re-used)
- Connect LED strip lights (two contact sides required)
- C = cut length
- P = contact surface length

Maximum visual strip length applies for an imperceptible drop in luminous flux of max. 30%.

ORDERING INFORMATION

Voltage	Number of LEDs/m	Colour temperature	Wattage	Luminous flux	Luminous efficiency	Colour rendering index CRI		Energy efficiency class	Section length C	Length of contact surface P	Max. strip length (visual)	Available length	
						R _a	R ₉					5 m	15 m
V		K	W/m	lm/m	lm/W	R _a	R ₉		mm	mm	m	5 m	15 m
5 24 V	120	Häfele Loox5 LED 3041											
		2700	9.6	870	91	>90	>50	A G	50	3	5.5	833.76.308	833.76.312
		3000	9.6	930	97	>90	>50	A F	50	3	5.5	833.76.309	833.76.313
		4000	9.6	955	99	>90	>50	A F	50	3	5.5	833.76.310	833.76.314
		5000	9.6	990	103	>90	>50	A F	50	3	5.5	833.76.311	-



> 3.5 A/20 AWG lead for LED strip light 5 mm

Voltage	Length mm	Article No.
5 12 V	2000	833.95.705
5 24 V	2000	833.95.711

> 3.5 A/20 AWG interconnecting lead for 5 mm LED strip light

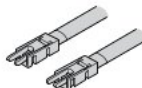

Length mm	Article No.
500	833.89.195



> 3.5 A clip connector for 5 mm LED strip light

Clip connector	Article No.
	833.89.207

> Corner connector, 90° rigid, 3.5 A for 5 mm LED strip light, left or right application



Corner connector rigid	Article No.
	833.89.190

LED Strip Lights

Monochrome, 8 mm

Häfele Loox5 LED 2071 / 2074; Standard



LED 2071



LED 2074

Illuminance value in lx applies to 1 m strip length:

2700 K	3000 K	4000 K	5000 K	120°	
1050 lx	1090 lx	1120 lx	1130 lx		250 mm
435 lx	455 lx	460 lx	470 lx		500 mm
240 lx	245 lx	260 lx	260 lx		750 mm
145 lx	150 lx	155 lx	160 lx		1000 mm

LED 2071

2700 K	3000 K	4000 K	5000 K	120°	
2145 lx	2250 lx	2300 lx	2300 lx		250 mm
900 lx	940 lx	950 lx	955 lx		500 mm
480 lx	505 lx	510 lx	515 lx		750 mm
300 lx	310 lx	320 lx	320 lx		1000 mm

LED 2074

ORDERING INFORMATION

Voltage	Number of LEDs/m	Colour temperature	Wattage	Luminous flux	Luminous efficiency	Colour rendering index CRI		Weight, energy consumpt. per m in kWh/1000 h	Section length C	Length of contact surface P	Max. strip length (visual)	Available length	
						R _a	R ₉					5 m	50 m
V		K	W/m	lm/m	lm/W	R _a	R ₉		mm	mm	m	5 m	50 m
5 12V	Häfele Loox5 LED 2071												
	60	2700	4.8	440	92	>90	>50	5.28	50	4	6.0	833.74.300	833.74.304
		3000	4.8	465	97	>90	>50	5.28	50	4	6.0	833.74.301	833.74.305
		4000	4.8	490	102	>90	>50	5.28	50	4	6.0	833.74.302	833.74.306
		5000	4.8	495	103	>90	>50	5.28	50	4	6.0	833.74.303	833.74.307
	Häfele Loox5 LED 2074												
	120	2700	9.6	920	96	>90	>50	10.56	25	4	3.5	833.74.308	833.74.312
		3000	9.6	970	101	>90	>50	10.56	25	4	3.5	833.74.309	833.74.313
		4000	9.6	1000	104	>90	>50	10.56	25	4	3.5	833.74.310	833.74.314
		5000	9.6	1040	108	>90	>50	10.56	25	4	3.5	833.74.311	833.74.315

Equipped with high-quality Samsung LEDs

- Dimmable: Yes
- Material: Plastic
- Finish/colour: White
- Width: 8 mm
- Height: 1.3 mm
- Life time L80/B10: >30,000 h
- Energy efficiency class: A+
- Degree of protection: IP20
- Mounting: Self-adhesive
- Supplied with: 1 roll

Order reference: Please order lead separately.

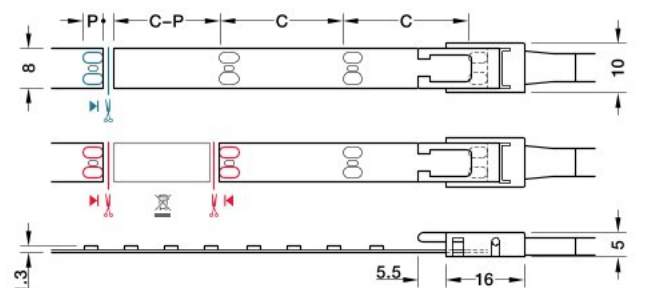

- Cut LED strip light to length (one contact side remains on the remainder piece; reusable)
- Connect LED strip lights (two contact sides required)
- C = section length
- P = length of contact surface

Maximum visual strip length applies for an imperceptible drop in luminous flux of max. 30%.

	> 3.5A/20AWG lead for LED strip light 8 mm		
	Voltage	Length mm	Article No.
	5 12V	2000	833.72.716
	> 5 A/18 AWG interconnecting lead for 8 mm LED strip light		
	Length mm	Article No.	
	500	833.89.192	
	> 5 A clip connector for 8 mm LED strip light		
	Article No.		
	Clip connector		833.89.206
	> Corner connector, 90° rigid, 5 A for 8 mm LED strip light, for left or right application		
	Article No.		
	Corner connector rigid		833.89.187

LED Strip Lights

Monochrome 8mm

Häfele Loox5 LED 3071 / 3074; Standard



Illuminance value in lx applies to 1 m strip length:

2700 K	3000 K	4000 K	5000 K	120°	
1140 lx	1190 lx	1250 lx	1250 lx		250 mm
470 lx	490 lx	510 lx	510 lx		500 mm
250 lx	265 lx	280 lx	280 lx		750 mm
155 lx	160 lx	170 lx	170 lx		1000 mm

LED 3071

2700 K	3000 K	4000 K	5000 K	120°	
2230 lx	2270 lx	2400 lx	2400 lx		250 mm
925 lx	940 lx	990 lx	990 lx		500 mm
500 lx	505 lx	530 lx	530 lx		750 mm
305 lx	310 lx	330 lx	320 lx		1000 mm

LED 3074

- Dimmable: Yes
- Material: Plastic
- Finish/colour: White
- Width: 8 mm
- Height: 1.3 mm
- Life time L80/B10: >30,000 h
- Length contact surface P: 3.9 mm
- Energy efficiency class: A+
- Degree of protection: IP20
- Mounting: Self-adhesive
- Supplied with: 1 roll

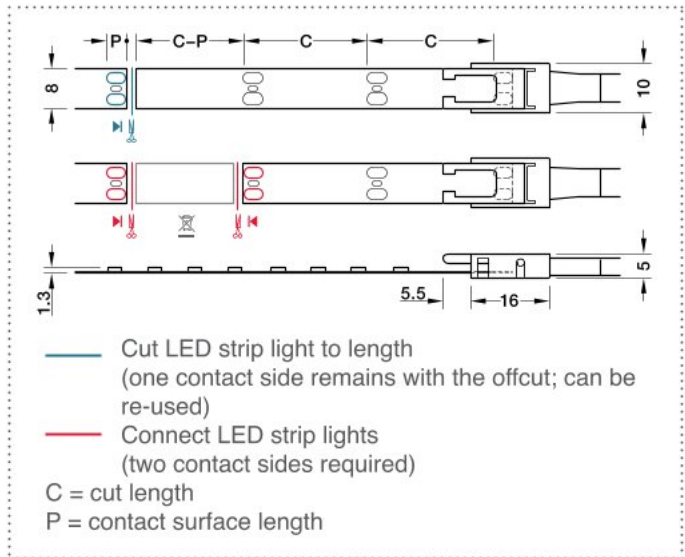

ORDERING INFORMATION

Voltage	Number of LEDs/m	Colour temperature	Wattage	Luminous flux	Luminous efficiency	Colour rendering index CRI		Weighted energy consumption	Energy efficiency class	Section length C	Available length		Max. strip length (lumen maintenance 30 %)
						R _a	R ₉				5 m	50 m	
V		K	W/m	lm/m	lm/W			kWh/1000 h		mm			mm
5 _{24V}	Häfele Loox5 LED 3071												
	120	2700	4.8	435	91	>90	>50	5.38	A+	50	833.75.210	833.75.215	9.50
		3000		460	96						833.75.211	833.75.216	
		4000		480	100						833.75.212	833.75.217	
		5000		480	100						833.75.213	833.75.218	
	Häfele Loox5 LED 3074												
	120	2700	9.6	830	86	>90	>50	10.56	A+	50	833.75.240	833.75.245	6.50
		3000		905	94						833.75.241	833.75.246	
		4000		960	100						833.75.242	833.75.247	
		5000		940	98						833.75.243	833.75.248	

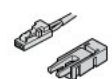

> 3.5A/20AWG lead for LED strip light 8 mm

Voltage	Length mm	Article No.
5 _{24V}	2000	833.75.705



> 5 A clip connector for 8 mm LED strip light

	Article No.
Clip connector	833.89.206

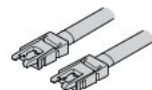

> 5 A/18 AWG interconnecting lead for 8 mm LED strip light

Length mm	Article No.
500	833.89.192



> Corner connector, 90° rigid, 5 A for left or right for 8 mm LED strip light

	Article No.
Corner connector rigid	833.89.187

LED Strip Lights

Monochrome 8mm

Häfele Loox5 LED 3075; Standard



LED 3075

Illuminance value lx applies to 1 m strip length:

2700 K	3000 K	4000 K	5000 K		120°
3135 lx	3305 lx	3400 lx	3400 lx		250 mm
1295 lx	1365 lx	1400 lx	1400 lx		500 mm
695 lx	735 lx	750 lx	750 lx		750 mm
425 lx	450 lx	460 lx	460 lx		1000 mm

LED 3075

- !** Maximum strip length (visual) describes a strip section with a visually imperceptible drop in luminous flux of max. 30 %.
- Please note:** A strip section with a new power supply that follows immediately is noticeably brighter.
- Please calculate max. strip light length on driver in accordance with power output: Length = power output of one driver socket/ output per metre.

- **Dimmable:** Yes
- **Material:** Plastic
- **Finish/Colour:** White
- **Width:** 8 mm
- **Height:** 1.3 mm
- **Life time L80/B10:** >30,000 h
- **Length contact surface P:** 3.9 mm
- **Energy efficiency class:** A+
- **Degree of protection:** IP20
- **Installation:** Self-adhesive
- **Supplied with:** 1 roll

! Order reference: Please order lead separately.

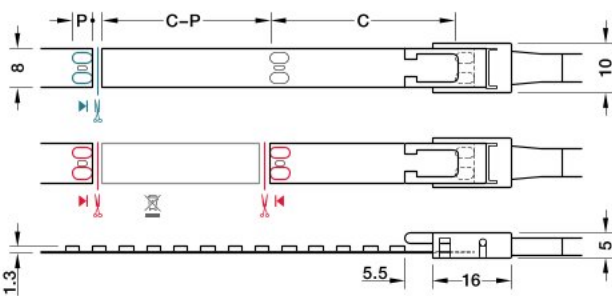

- Cut LED strip light to length (one contact side remains with the offcut; can be re-used)
- Connect LED strip lights (two contact sides required)
- C = cut length
- P = contact surface length

ORDERING INFORMATION

Voltage	Number of LEDs/m	Colour temperature	Wattage	Luminous flux	Luminous efficiency	Colour rendering index	Weighted energy consumption	Section length C	Max. strip length (visual)	Available length	
V		K	W/m	lm/m	lm/W	R _a	kWh/1000 h	mm	m	5 m	50 m
Häfele Loox5 LED 3075											
5 ^{24V}	140	2700	14.4	1430	99	>90	15.84	50	4.5	833.75.200	833.75.204
		3000		1500	104	>90	15.84	50	4.5	833.75.201	833.75.205
		4000		1550	108	>90	15.84	50	4.5	833.75.202	833.75.206
		5000		1570	109	>90	15.84	50	4.5	833.75.203	833.75.207

+ > 3.5A/20AWG lead for LED strip light 8 mm

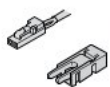

Voltage	Length mm	Article No.
5 ^{24V}	2000	833.75.705



> 5 A clip connector for 8 mm LED strip light

	Article No.
Clip connector	833.89.206

> 5 A/18 AWG interconnecting lead for 8 mm LED strip light



Length mm	Article No.
500	833.89.192



> Corner connector, 90° rigid, 5 A for left or right for 8 mm LED strip light

	Article No.
Corner connector rigid	833.89.187

LED Strip Lights

Monochrome 8mm

Häfele Loox5 LED 3076; Standard



LED 3076

Illuminance value lx applies to 1 m strip length:

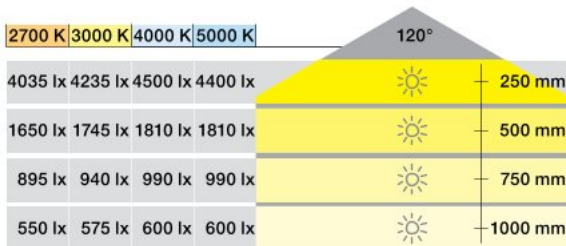

LED 3076



Note

The Häfele Loox5 LED 3076 LED strip light requires cooling through an aluminum profile with a cross-section > 45 mm². Suitable profiles are e.g. Loox5 1105 and 1106 profiles for recess mounting and 2104 profiles for under mounting.

- **Dimmable:** Yes
- **Material:** Plastic
- **Finish/Colour:** White
- **Width:** 8 mm
- **Height:** 1.3 mm
- **Life time L80/B10:** >30,000 h
- **Length contact surface P:** 4 mm
- **Energy efficiency class:** A+
- **Degree of protection:** IP20
- **Installation:** Self-adhesive
- **Supplied with:** 1 roll

! **Order reference:** Please order lead separately.



Maximum strip length (visual) describes a strip section with a visually imperceptible drop in luminous flux of max. 30 %.
Please note: A strip section with a new power supply that follows immediately is noticeably brighter.
 Please calculate max. strip light length on driver in accordance with power output: Length = power output of one driver socket/output per metre.

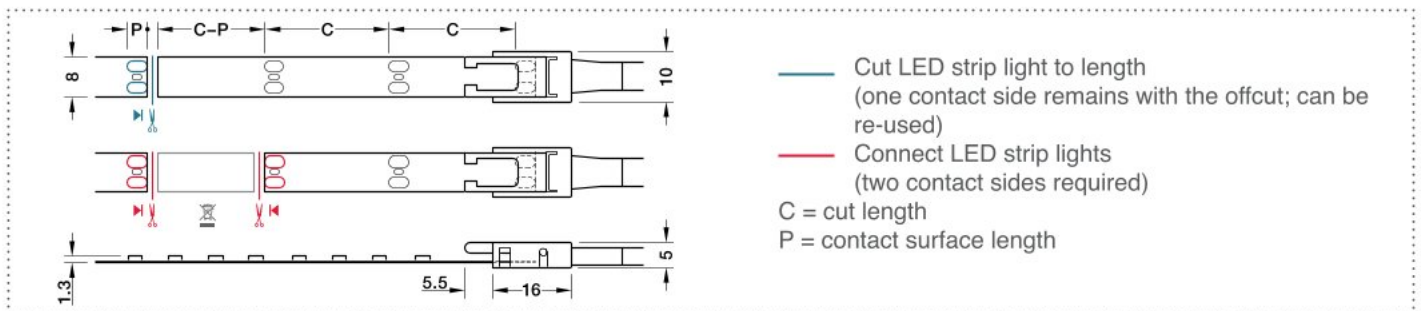

ORDERING INFORMATION

Voltage	Number of LEDs/m	Colour temperature	Wattage	Luminous flux	Luminous efficiency	Colour rendering index	Weighted energy consumption kWh/1000 h	Section length C	Max. strip length (visual)	Available length	
										5 m	50 m
V		K	W/m	lm/m	lm/W	R _a		mm	m		
Häfele Loox5 LED 3076											
5 ^{24V}	120	2700	19.2	1490	78	>90	21.12	50	5.0	833.75.250	833.75.255
		3000		1610	84	>90	21.12	50	5.0	833.75.251	833.75.256
		4000		1670	87	>90	21.12	50	5.0	833.75.252	833.75.257
		5000		1700	89	>90	21.12	50	5.0	833.75.253	833.75.258



> 3.5A/20AWG lead for LED strip light 8 mm

Voltage	Length mm	Article No.
5 ^{24V}	2000	833.75.705



> 5 A clip connector for 8 mm LED strip light

	Article No.
Clip connector	833.89.206

> 3.5A/20AWG interconnecting lead for 8 mm LED strip light

Length mm	Article No.
500	833.89.192



> Corner connector, 90° rigid, 5 A for left or right for 8 mm LED strip light

	Article No.
Corner connector rigid	833.89.187

LED Strip Lights

Monochrome, 8 mm

Häfele Loox5 LED 3052



LED 3052

Illuminance value in lx applies to 1 m strip length:

2700 K	3000 K	4000 K	5000 K	120°	
4070 lx	4160 lx	4220 lx	4260 lx		250 mm
1750 lx	1780 lx	1800 lx	1840 lx		500 mm
970 lx	990 lx	1000 lx	1020 lx		750 mm
600 lx	620 lx	625 lx	630 lx		1000 mm

LED 3052

Constant current technology

- > Achieves uniform brightness over the entire strip light length
- > Increased life time, higher visual strip length, higher luminous efficacy
- Equipped with high-quality Samsung LEDs

- Dimmable: Yes
- Material: Plastic
- Finish/colour: White
- Width: 8 mm
- Height: 1.5 mm
- Life time L80/B10: >50,000 h
- Life time L70/B50: >100,000 h
- Degree of protection: IP20
- Mounting: Self-adhesive
- Supplied with: 1 roll

! Order reference: Please order lead separately.

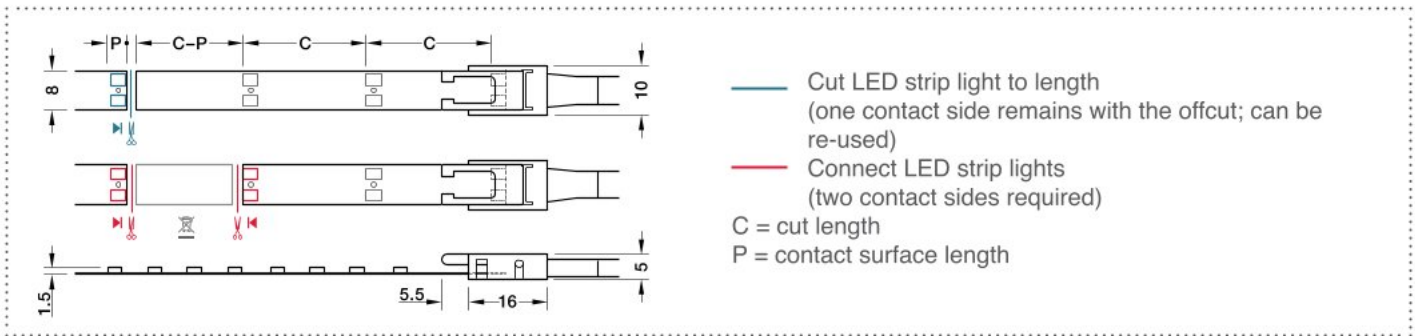

ORDERING INFORMATION

Voltage	Number of LEDs/m	Colour temperature	Wattage	Luminous flux	Luminous efficiency	Colour rendering index CRI		Energy efficiency class	Section length C	Length of contact surface P	Max. strip length (visual)	Available length
						R _a	R ₉					
V		K	W/m	lm/m	lm/W				mm	mm	m	5 m
Häfele Loox5 LED 3052												
5 24 V	140	2700	19.2	1850	96	>90	>50		50	3	6.0	833.76.378
		3000	19.2	2015	105	>90	>50		50	3	6.0	833.76.379
		4000	19.2	2050	107	>90	>50		50	3	6.0	833.76.380
		5000	19.2	2100	109	>90	>50		50	3	6.0	833.76.381

! The maximum visual strip length for Loox5 constant current strips is the length without drop in luminous flux.

+

Voltage	Length mm	Article No.
5 24 V	2000	833.95.706

> 5 A/18 AWG interconnecting lead for 8 mm LED strip light

Length mm	Article No.
500	833.89.192

Article No.
Clip connector
833.89.206

> Corner connector, 90° rigid, 5 A for left or right for 8 mm LED strip light

Article No.
Corner connector rigid
833.89.187

LED Strip Lights

Monochrome, 8 mm

Häfele Loox5 LED 2062 /3045 / 3048



LED 2062



LED 3045 / 3048

Equipped with high-quality Samsung LEDs

- Dimmable: Yes
- Material: Plastic
- Finish/colour: White
- Width: 8 mm
- Height: 1.3 mm
- Life time L80/B10: >50,000 h
- Life time L70/B50: >80,000 h
- Degree of protection: IP20
- Mounting: Self-adhesive
- Supplied with: 1 roll

! Order reference: Please order lead separately.

Illuminance value in lx applies to 1 m strip length:

2700 K	3000 K	4000 K	5000 K	Beam Angle	Distance
1050 lx	1090 lx	1120 lx	1130 lx	120°	250 mm
435 lx	455 lx	460 lx	470 lx	120°	500 mm
240 lx	245 lx	260 lx	260 lx	120°	750 mm
145 lx	150 lx	155 lx	160 lx	120°	1000 mm

LED 2062

2700 K	3000 K	4000 K	5000 K	Beam Angle	Distance
2145 lx	2250 lx	2300 lx	2300 lx	120°	250 mm
900 lx	940 lx	950 lx	955 lx	120°	500 mm
480 lx	505 lx	510 lx	515 lx	120°	750 mm
300 lx	310 lx	320 lx	320 lx	120°	1000 mm

LED 3045

2700 K	3000 K	4000 K	5000 K	Beam Angle	Distance
2870 lx	3000 lx	3100 lx	3100 lx	120°	250 mm
1210 lx	1270 lx	1310 lx	1320 lx	120°	500 mm
665 lx	695 lx	715 lx	715 lx	120°	750 mm
415 lx	430 lx	445 lx	450 lx	120°	1000 mm

LED 3048

! Maximum visual strip length applies for an imperceptible drop in luminous flux of max. 30%.

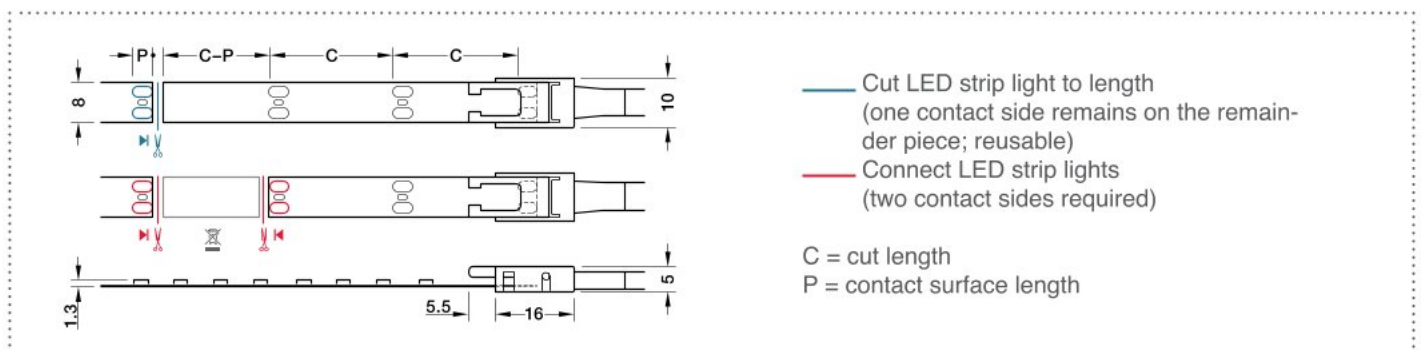

ORDERING INFORMATION

Voltage	Number of LEDs/m	Colour temperature	Watt-age	Lumi-nous flux	Lumi-nous efficiency	Colour rendering index CRI		Energy efficiency class	Sec-tion length C	Length of contact surface P	Max. strip length (visual)	Available length
						R _a	R _g					
V		K	W/m	lm/m	lm/W	R _a	R _g		mm	mm	m	5 m
5 12V	Häfele Loox5 LED 2062											
	60	2700	4.8	440	92	>90	>50		50	4	6.0	833.74.336
		3000	4.8	465	97	>90	>50		50	4	6.0	833.74.337
		4000	4.8	490	102	>90	>50		50	4	6.0	833.74.338
		5000	4.8	495	103	>90	>50		50	4	6.0	833.74.339
5 24V	Häfele Loox5 LED 3045											
	120	2700	9.6	920	96	>90	>50		50	4	8.0	833.76.334
		3000	9.6	970	101	>90	>50		50	4	8.0	833.76.335
		4000	9.6	1000	104	>90	>50		50	4	8.0	833.76.336
		5000	9.6	1040	108	>90	>50		50	4	8.0	833.76.337
	Häfele Loox5 LED 3048											
	120	2700	14.4	1270	88	>90	>50		50	4	6.2	833.76.352
		3000	14.4	1305	91	>90	>50		50	4	6.2	833.76.353
		4000	14.4	1340	93	>90	>50		50	4	6.2	833.76.354
		5000	14.4	1430	99	>90	>50		50	4	6.2	833.76.355



> 5 A/18 AWG lead for LED strip light 8 mm

Voltage	Length mm	Article No.
5 12V	2000	833.95.700
5 24V	2000	833.95.706



> 5 A clip connector for 8 mm LED strip light

	Article No.
Clip connector	833.89.206

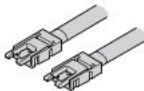

> 5 A/18 AWG interconnecting lead for 8 mm LED strip light

Length mm	Article No.
500	833.89.192



> Corner connector, 90° rigid, 5 A for left or right for 8 mm LED strip light

	Article No.
Corner connector rigid	833.89.187

LED Silicone Strip Lights

Monochrome, 8 mm

Häfele Loox5 LED 3046



LED 3046

Illuminance value in lx applies to 1 m strip length:

2700 K	3000 K	4000 K	5000 K	120°	
1855 lx	1895 lx	1960 lx	2020 lx		250 mm
790 lx	805 lx	840 lx	860 lx		500 mm
435 lx	445 lx	465 lx	475 lx		750 mm
270 lx	275 lx	290 lx	295 lx		1000 mm

LED 3046

Equipped with high-quality Samsung LEDs

- **Dimmable:** Yes
- **Material:** Silicone
- **Finish/colour:** White
- **Width:** Strip: 8 mm, silicone sleeve: 10 mm
- **Height: Strip:** 1.3 mm, silicone sleeve: 4.8 mm
- **Life time L80/B10:** >50,000 h
- **Life time L70/B50:** >80,000 h
- **Degree of protection:** IP44 / optional IP20
- **Mounting:** Self-adhesive
- **Supplied with:** 1 roll

! **Order reference:** Please order lead separately.

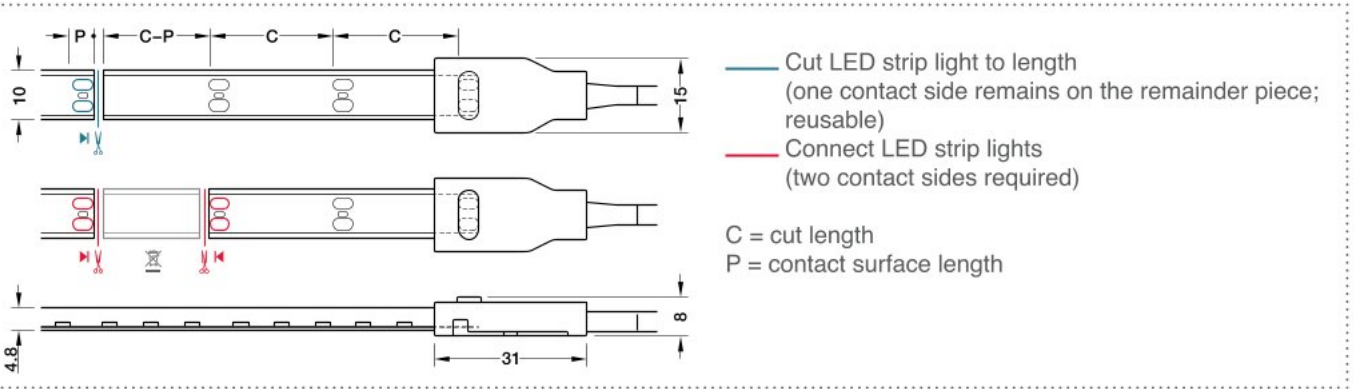

ORDERING INFORMATION

Voltage	Number of LEDs/m	Colour temperature	Wattage	Luminous flux	Luminous efficiency	Colour rendering index CRI		Energy efficiency class	Section length C	Length of contact surface P	Max. strip length (visual)	Available length
						R _a	R ₉					
V		K	W/m	lm/m	lm/W				mm	mm	m	5 m
Häfele Loox5 LED 3046												
5 24V	120	2700	9.6	820	85	>90	>50		50	4	8.0	833.76.342
		3000	9.6	870	91	>90	>50		50	4	8.0	833.76.343
		4000	9.6	900	94	>90	>50		50	4	8.0	833.76.344
		5000	9.6	930	97	>90	>50		50	4	8.0	833.76.345

! Maximum visual strip length applies for an imperceptible drop in luminous flux of max. 30%.

+ **Degree of protection IP44**

> 5 A/18 AWG lead for 8 mm LED silicone strip light

Voltage	Length mm	Article No.
5 24V	2000	833.95.709

> 5 A/18 AWG interconnecting lead for 8 mm LED silicone strip light

Length mm	Article No.
500	833.89.204

> End cap set with adhesive for 8 mm LED silicone strip light for sealing the shortened silicone sleeve; achieves degree of protection IP44

	Article No.
Set of 5, with 5 ml adhesive	833.89.184

LED Silicone Strip Lights

Monochrome, lateral light emission



Häfele Loox5 LED 3099



LED 3099

Illuminance in lx in relation to 1 m strip length:

2700 K				3000 K				4000 K				5000 K				120°	
820 lx	840 lx	845 lx	860 lx	190 lx	195 lx	205 lx	215 lx	85 lx	90 lx	100 lx	100 lx	50 lx	50 lx	55 lx	55 lx		250 mm
																	500 mm
																	750 mm
																	1000 mm

LED 3099

Lateral light emission, IP44

- Light opening at the narrow side, no visible LED points
 - Slight groove (width 4 mm) and flat surface, shelves remain adjustable
 - Wave and ring shaped installation possible (radius min. 30 mm)
 - Can be split once: Both pieces with separate lead
 - Splash proof for use in wet rooms
- **Finish/colour:** Matt white
 - **Width:** Strip: 8 mm, silicone sleeve: 10 mm
 - **Height: silicone sleeve:** 4 mm
 - **Life time L80/B10:** >50,000 h
 - **Energy efficiency class:** G
 - **Degree of protection:** IP44
 - **Mounting:** For press fitting into groove
 - **Routing width:** 4.5 mm
 - **Routing depth:** 10 mm
 - **Supplied with:** 1 roll with 2 x 0.2 m soldered lead 3.5 A/20 AWG (1 each on the left/right of the strip)

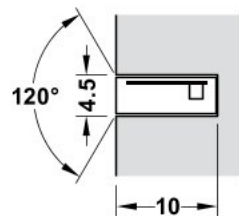
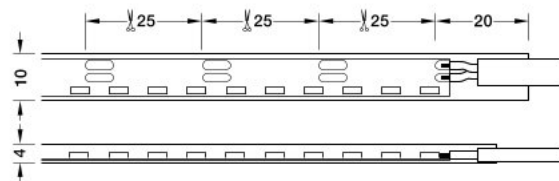

Installation in groove

! Maximum visual strip length applies for an imperceptible drop in luminous flux of max. 30%.

ORDERING INFORMATION

Voltage V	Number of LEDs/m	Colour temperature K	Wattage W/m	Luminous flux lm/m	Luminous efficiency lm/W	Colour rendering index CRI		Section length C mm	Length of contact surface P mm	Max. strip length (visual) m	Available length	
						R _a	R _g				3 m	5 m
Häfele Loox5 LED 3099												
5 24V	120	2700	9.6	500	52	>90	>50	25	6	3.0	833.75.260	833.75.265
		3000	9.6	520	54	>90	>50	25	6	3.0	833.75.261	833.75.266
		4000	9.6	540	56	>90	>50	25	6	3.0	833.75.262	833.75.267
		5000	9.6	540	56	>90	>50	25	6	3.0	833.75.263	833.75.268



LED Strip Lights

Multi-white, 8 mm

Häfele Loox5 LED 2076; Standard



LED 2076

Illuminance value in lx applies to 1 m strip length:

2700 K	5000 K	120°	
2040 lx	2110 lx		250 mm
850 lx	875 lx		500 mm
460 lx	470 lx		750 mm
280 lx	290 lx		1000 mm

LED 2076

! Order reference: Please order lead separately.

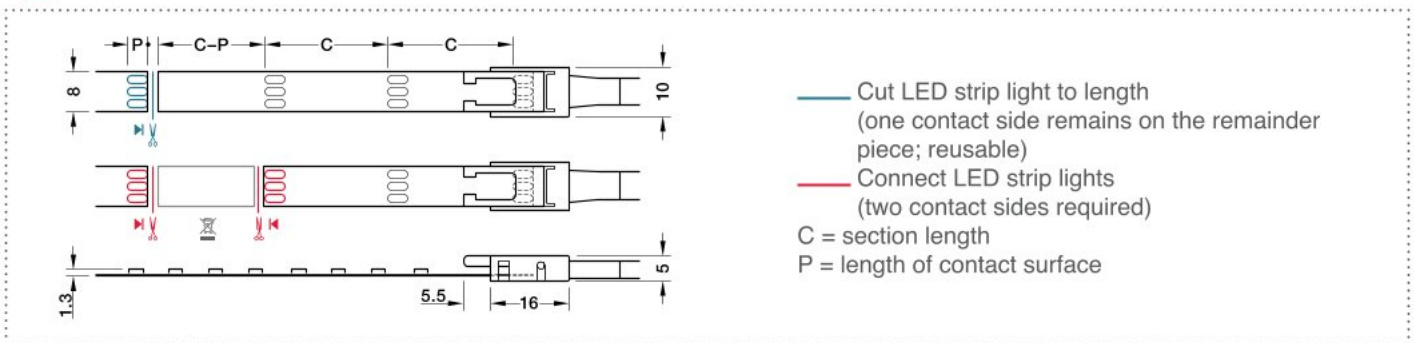

ORDERING INFORMATION

Voltage	Number of LEDs/m	Colour temperature	Wattage	Luminous flux	Luminous efficiency	Colour rendering index CRI		Weight. energy consumpt. per m in	Section length C	Length of contact surface P	Max. strip length (visual)	Available length
V		K	W/m	lm/m	lm/W	R _a	R _o	kWh/1000 h	mm	mm	m	5 m
5 12V	Häfele Loox5 LED 2076											
	2 x 120	2700 5000	9.6	875 940	91 97	>90	>50	10.56	25	3.5	3	833.74.318

! Maximum visual strip length applies for an imperceptible drop in luminous flux of max. 30%.

	> 3.5 A/20 AWG lead for 8 mm multi-white LED strip light <table border="1"> <tr> <th>Voltage</th> <th>Length mm</th> <th>Article No.</th> </tr> <tr> <td>5 12V</td> <td>2000</td> <td>833.95.702</td> </tr> </table>	Voltage	Length mm	Article No.	5 12V	2000	833.95.702		> 3.5 A clip connector for 8 mm multi-white LED strip light <table border="1"> <tr> <th>Article No.</th> </tr> <tr> <td>Clip connector</td> </tr> <tr> <td>833.89.208</td> </tr> </table>	Article No.	Clip connector	833.89.208
	Voltage	Length mm	Article No.									
5 12V	2000	833.95.702										
Article No.												
Clip connector												
833.89.208												
	> Corner connector 90° rigid, 3.5 A for left or right for 8 mm multi-white LED strip light <table border="1"> <tr> <th>Article No.</th> </tr> <tr> <td>Corner connector rigid</td> </tr> <tr> <td>833.89.188</td> </tr> </table>	Article No.	Corner connector rigid	833.89.188		> 3.5 A/20 AWG interconnecting lead for 8 mm multi-white LED strip light <table border="1"> <tr> <th>Length mm</th> <th>Article No.</th> </tr> <tr> <td>500</td> <td>833.89.198</td> </tr> </table>	Length mm	Article No.	500	833.89.198		
Article No.												
Corner connector rigid												
833.89.188												
Length mm	Article No.											
500	833.89.198											

LED Strip Lights

Multi-white

Häfele Loox5 LED 3014 / 3016



LED 3014

2700 K		5000 K			
2130 lx	2390 lx		250 mm		
672 lx	976 lx		500 mm		
467 lx	523 lx		750 mm		
289 lx	322 lx		1000 mm		



2700 K		5000 K			
3150 lx	3422 lx		250 mm		
1296 lx	1403 lx		500 mm		
697 lx	754 lx		750 mm		
430 lx	462 lx		1000 mm		

LED 3016

- **Dimmable:** Yes
- **Finish/colour:** White
- **Length:** 5000 mm / 50000 mm
- **Width:** 8 mm
- **Height:** 1.3 mm
- **Lifetime L80/B10:** > 30,000 hours
- **Energy efficiency class:** A+
- **Degree of protection:** IP20
- **Mounting:** Self adhesive

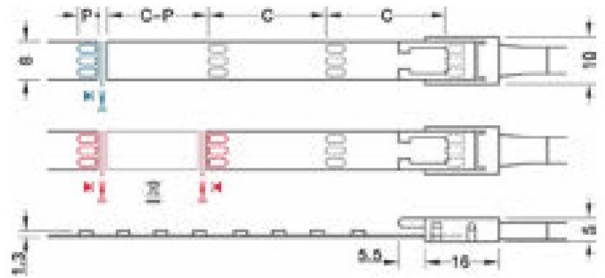

— Cut LED strip light to length (one contact side remains with the offcut; can be reused)

— Connect LED strip lights (two contact sides required)

C = cut length

P = contact surface length

+ > 3.5 A/20 AWG lead for 8 mm multi-white LED strip light



Voltage	Length (mm)	Article No.
5 12V	2000	833.95.702
5 24V	2000	833.95.708

ORDERING INFORMATION

Voltage	Number of LEDs/m	Colour temperature	Wattage	Luminous flux	Luminous efficiency	Colour rendering index		Weighted energy consumption kWh/1000 h	Section length C	Contact surface Length P	Available Length	
						R _a	R ₉				5m	50 m
V		K	W/m	lm/m	lm/W				mm	mm		
Häfele Loox LED 3014												
	2x 120	2700	9.6	866	88	>90	>50	5.28	50	4	833.72.270	833.72.271
		5000		950	96							
Häfele Loox LED 3016												
5 24V	2x 120	2700	14.4	1296	91	>90	>50	10.56	50	3.5	833.77.280	833.77.281
		5000		1409	97							



LED Strip Lights

RGB, 10 mm

Häfele Loox5 LED 3080

- **Dimmable:** Yes
- **Material:** Plastic
- **Finish/colour:** White
- **Width:** 10 mm
- **Height:** 2.4 mm
- **Degree of protection:** IP20
- **Mounting:** Self-adhesive
- **Supplied with:** 1 roll



LED 3080

! Order reference: Please order lead separately.

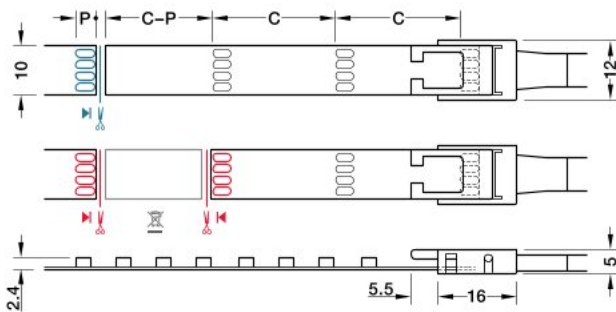

- Cut LED strip light to length (one contact side remains on the remainder piece; reusable)
- Connect LED strip lights (two contact sides required)
- C = cut length
- P = contact surface length

! Ordering instruction

For Controlling of RGB lights order Mesh as per page no. 314

ORDERING INFORMATION

Voltage	Number of LEDs/m	Colour temperature K	Wattage	Luminous flux	Luminous efficiency	Section length C	Length of contact surface P	Max. strip length (visual)	Available length
V			W/m	lm/m	lm/W	mm	mm	m	5 m
Häfele Loox5 LED 3080									
5 24V	120	RGB	9.6	530	51	50	3.8	6.5	833.76.386

! Maximum visual strip length applies for an imperceptible drop in luminous flux of max. 30%.

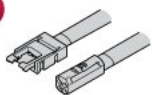

> 3.5 A/20 AWG lead for LED RGB strip light, 10 mm

Voltage	Length mm	Article No.
5 24V	2000	833.95.710



> 3.5 A clip connector for LED RGB strip light, 10 mm

Article No.
Clip connector
833.89.209

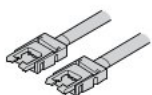

> 3.5 A/20 AWG interconnecting lead for LED RGB strip light, 10 mm

Length mm	Article No.
500	833.89.201



> Corner connector, 90° rigid, 3.5 A for left or right for LED RGB strip light, 10 mm

Article No.
Corner connector rigid
833.89.189

Loox LED Driver

Häfele Loox driver constant voltage 12V

- **Version:** With overload protection
- **Colour:** Black
- **Degree of protection:** IP20
- **Input voltage:** 100–240 V~; 50–60 Hz
- **Output voltage:** DC 12 V
- **Number of connections:** 6 x consumer, 1 x switch
- **Supplied with:** 1 driver with mounting accessories



The driver is the heart of the Loox system, and is suitable for connecting to all of the worlds most frequently used mains voltages and frequencies. All of the switches in the Loox product range can be connected to the drivers with a universal switch input. All drivers are energy efficient and equipped with overload protection.

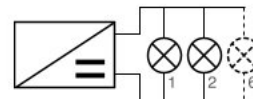

Parallel connection

- ! > Lead length from driver to switch max. 6 m.
- ! > Provide for sufficient air supply and circulation at the mounting location of the driver.

+ Country-specific mains leads

> Supplied with: 1 piece

Plug design	Article No.
	833.89.002
	833.89.009

- ! 1 Article No.: 833.74.960
 $\otimes_1 + \otimes_2 + \dots + \otimes_6 < 20 \text{ W}$
- ! 2 Article No.: 833.74.962
 $\otimes_1 + \otimes_2 + \dots + \otimes_6 < 40 \text{ W}$
- ! 3 Article No.: 833.74.964
 $\otimes_1 + \otimes_2 + \dots + \otimes_6 < 60 \text{ W}$
max. 42 W per light output

ORDERING INFORMATION

12V	Output power	Output current	Standby power consumption	Dimensions	Article No.
	W	A	W	(L x W x H) mm	
1	0-20	1.67	≤0.1	140 x 50 x 16	833.74.960
2	0-40	3.33	≤0.1	190 x 60 x 16	833.74.962
3	0-90	3.5	≤0.2	230 x 70 x 16	833.74.913

Loox LED Driver

Constant voltage 24 V

Häfele Loox driver constanty voltage 24V

- **Version:** With overload protection
- **Colour:** Black
- **Degree of protection:** IP20
- **Input voltage:** 100–240 V~; 50–60 Hz
- **Output voltage:** DC 24 V
- **Number of connections:** 6 x consumer, 1 x switch
- **Supplied with:** 1 driver with mounting accessories



1



2



3

The driver is the heart of the Loox system, and is suitable for connecting to all of the world's most frequently used mains voltages and frequencies. All of the switches in the Loox product range can be connected to the drivers with a universal switch input. All drivers are energy efficient and equipped with overload protection.

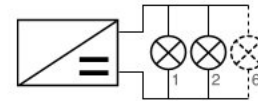

Parallel connection

- ! > Lead length from driver to switch max. 6 m.
- ! > Provide for sufficient air supply and circulation at the mounting location of the driver.

+ Country-specific mains leads

> Supplied with: 1 piece

Plug design	Article No.
	833.89.002
	833.89.009

- ! 1 Article No.: 833.77.945
 $\otimes_1 + \otimes_2 + \dots + \otimes_6 < 20 \text{ W}$
- ! 2 Article No.: 833.77.947
 $\otimes_1 + \otimes_2 + \dots + \otimes_6 < 40 \text{ W}$
- ! 3 Article No.: 833.77.949
 $\otimes_1 + \otimes_2 + \dots + \otimes_6 < 90 \text{ W}$
max. 84 W per light output

ORDERING INFORMATION

	Output power	Output current	Standby power consumption	Dimensions	Article No.
24 V	W	A	W	(L x W x H) mm	
1	0-20	0.83	≤0.1	140 x 50 x 16	833.77.945
2	0-40	1.67	≤0.1	190 x 60 x 16	833.77.947
3	0-90	3.5	≤0.2	316 x 70 x 16	833.77.949

Drivers

Häfele Loox5 driver constant voltage 12 V

- **Version:** With overload protection
- **Colour:** Black
- **Degree of protection:** IP20
- **Output voltage:** DC 12 V +/- 3 %
- **Number of connections:** 1x socket Loox5 12 V
- **Supplied with:** 1 driver with mounting accessories



! 833.95.000 is only permitted for use outside the EU.

! Ambient temperature -25 °C to +45 °C (60 W: 40 °C)
Ensure that there is a sufficient air supply and circulation at the mounting location.
The life time is doubled with an ambient temperature of <30° C.

! The maximum lead length from the Loox5 driver to the device is 10 m. Long cable lengths in combination with large loads (strip light lengths) can result in voltage losses in the cable. This leads to a visible loss of brightness in the lights. The illuminance listed with the lights has been determined by the rated output voltage of the driver (12 V or 24 V).

+ Mains lead, country-specific, C7 socket (small appliance plug), 2 metre lead length

- > Description: EU
- > Supplied with: 1 piece

Plug design	Article No.
	833.89.002
	833.89.009

Note: Distribution and Switching functions can be achieved with the Loox5 12 V Drivers with the help of Connect Mesh System, Box to Box Distributors and Adapters with Switching function.

ORDERING INFORMATION

5 12V	Output power	Output current	Mains voltage	Standby power consumption	Dimensions	Article No.
	W	A		W	(L x W x H) mm	
1	20	1.67	100–240 V~; 50–60 HZ	0.07	140 x 50 x 16	833.95.000
			220–240 V~; 50–60 HZ	0.08	140 x 50 x 16	833.95.001
2	40	3.33	100–240 V~; 50–60 HZ	0.12	191 x 60 x 16	833.95.002
3	60	5.00	100–240 V~; 50–60 HZ	0.14	230 x 70 x 16	833.95.003

Drivers

Häfele Loox5 driver constant voltage 24 V

- **Version:** With overload protection
- **Colour:** Black
- **Degree of protection:** IP20
- **Output voltage:** DC 24 V +/- 3 %
- **Number of connections:** 1x socket Loox5 24 V
- **Supplied with:** 1 driver with mounting accessories



! 833.95.000 is only permitted for use outside the EU.

! Ambient temperature -25 °C to +45 °C (60 W: 40 °C)
 Ensure that there is a sufficient air supply and circulation at the mounting location.
 The life time is doubled with an ambient temperature of <30° C.

+ Mains lead, country-specific, C7 socket (small appliance plug), 2 metre lead length

- > Description: EU
- > Supplied with: 1 piece

Plug design	Article No.
	833.89.002
	833.89.009

! The maximum lead length from the Loox5 driver to the device is 10 m. Long cable lengths in combination with large loads (strip light lengths) can result in voltage losses in the cable. This leads to a visible loss of brightness in the lights. The illuminance listed with the lights has been determined by the rated output voltage of the driver (12 V or 24 V).

Note: Distribution and Switching functions can be achieved with the Loox5 12 V Drivers with the help of Connect Mesh System, Box to Box Distributors and Adapters with Switching function.

ORDERING INFORMATION

5 24 V	Output power	Output current	Mains voltage	Standby power consumption	Dimensions (L x W x H) mm	Article No.
	W	A		W		
1	20	0.83	100–240 V~; 50–60 HZ	0.11	140 x 50 x 16	833.95.008
			220–240 V~; 50–60 HZ	0.10	140 x 50 x 16	833.95.009
2	40	1.67	100–240 V~; 50–60 HZ	0.15	191 x 60 x 16	833.95.010
3	60	3.75	100–240 V~; 50–60 HZ	0.21	316 x 70 x 16	833.95.011



Loox LED Driver

Häfele Loox5 driver constant voltage 24 V



- **Version:** With overload protection
- **Colour:** Black
- **Degree of protection:** IP20
- **Standby power consumption:** <0.5 W
- **Output voltage:** DC 24 V
- **Dim. (L x W x H):** 234 x 75 x 38 mm
- **Life time:** >50,000 hours
- **Supplied with:** 1 driver with mounting accessories

! Maximum lead length from the Loox5 driver to the device is 10 m. Long cable lengths in combination with large loads (strip light lengths) can result in voltage losses in the cable. These lead to visible loss of brightness in the lights. The illuminance listed with the lights has been determined with the rated output voltage of the driver. (12 V or 24 V).

ORDERING INFORMATION

5 24 V	Input voltage	Output power	Output current	Number of connections Loox5 24 V	Article No.
		W	A		
	200-240 V~, 50–60 Hz	240 (2 x 120)	2 x 5	2 x socket	833.95.012

Note: This product will require a 3 pin plug. Please refer to Article No.833.89.264

+ Loox5 24V Strip Light for 8mm Strip Light lead, 2m, to be ordered separately to connect with Loox5 240W LED driver

Häfele Loox5 lead for LED strip light monochrome, 8 mm

- **Current carrying capacity:** Max. 5A
- **Width: Clip:** 10 mm
- **Drill hole Ø:** Plug 8 mm
- **Supplied with:** 1 lead plug/clip

Type of cable	Voltage	Length mm	Article No.
Monochrome (2-wire 18 AWG)	5 24 V	2000	833.95.706

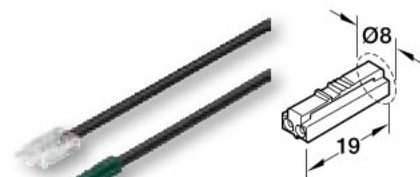

24 V monochrome

+ Country-specific main leads – 2 metre lead length, socket at the cable: C13

Country-specific mains leads

- **Supplied with:** 1 piece

Plug design	Article No.
	833.89.264

Profiles for Recess Mounting

Aluminium

- **Material:** Profile: Aluminium, Diffuser: Plastic
- **Finish/colour:** Profile: Anodized, Diffuser: White opal, transmittance 70-80 %
- **Length:** 3000 mm
- **Diffuser width:** Profile 1104: 8 mm, Profile 1103: 11 mm
- **Supplied with:** 1 aluminium profile
- 1 diffuser white opal

+ End caps for Häfele Loox5 profile 1104, 1103

- **Material:** Plastic
- **Version:** With cable outlet
- **Supplied with:** 5 pairs of end caps

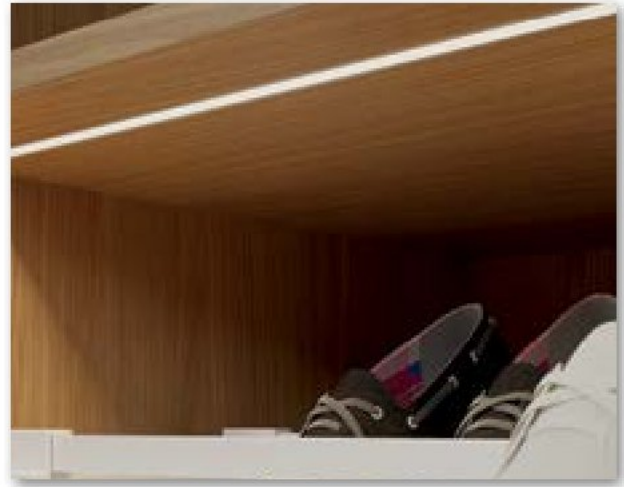

Häfele Loox5 profile 1104

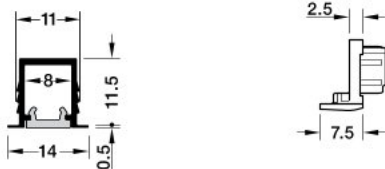
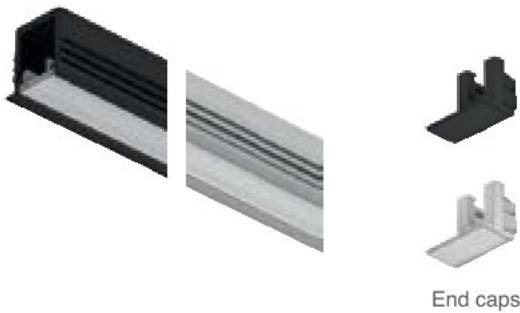

Häfele Loox5 profile 1103

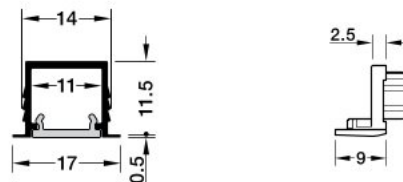
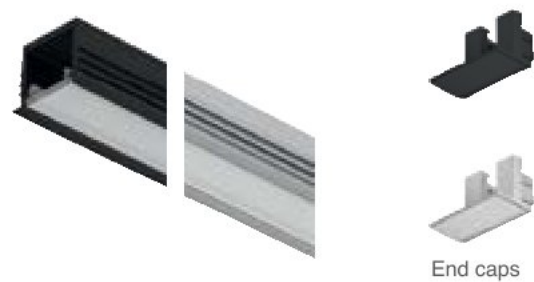

- !** **Diffusers**
 The diffuser creates a uniform light.
 The LED points are invisible from 120 LEDs/m.
 If required, please order alternative diffuser in black opal separately.

Note: Profile 1104 is usable for LED strip lights up to max. 5 mm width.

ORDERING INFORMATION

	Colour	Profile 1104	Profile 1103
1	Black	833.95.725	833.95.723
2	Silver coloured	833.95.724	833.95.722
End caps for Häfele Loox5 profile 1104, 1103			
	Colour	End cap 1104	End cap 1103
1	Black	833.95.769	833.95.767
2	Silver coloured	833.95.768	833.95.766



Profiles for Recess Mounting

Aluminium

Häfele Loox5 profile 1105, asymmetric light distribution



- **Material:** Profile: Aluminium, Diffuser: Plastic
- **Finish/colour:** Profile: Anodized, Diffuser: White opal, transmittance 70-80 %
- **Length:** 3000 mm
- **Diffuser width:** 11 mm
- **Supplied with:** 1 aluminium profile
- 1 diffuser white opal

+ End caps for Häfele Loox5 profile 1105

- **Material:** Plastic
- **Version:** With cable outlet
- **Packing:** 10 pieces

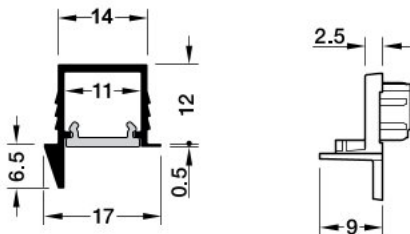
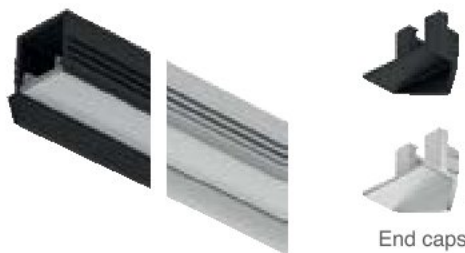

! **Diffusers**
The diffuser creates a uniform light.
The LED points are invisible from 120 LEDs/m.

Anti-glare shield
Asymmetric light distribution allows for a glare free light source.

ORDERING INFORMATION

	Colour	Article No.
1	Black	833.95.727
2	Silver coloured	833.95.726
End caps for Häfele Loox5 profile 1105		
	Colour	Article No.
1	Black	833.95.771
2	Silver coloured	833.95.770

Profiles for Recess Mounting

Aluminium

Häfele Loox Profile For Recess Mounting

- **Material:** Aluminium
- **Finish/colour:** Silver coloured anodized
- **Length x Width:** 2500 x 18 mm
- **Height:** 8.5 mm
- **Supplied with:** 1 profile, 1 diffuser

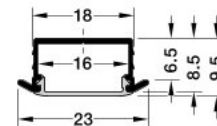
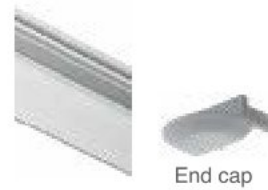

! LED points are always visible when this profile is used

+ End cap with cable outlet for 833.72.844

- **Material:** Plastic
- **Supplied with:** 2 pieces

ORDERING INFORMATION

	Colour	Article No.
1	Silver coloured with milky diffuser	833.72.844
	Description	Silver coloured
1	End cap with cable outlet for 833.72.844	833.72.855

Häfele Loox Profile For Recess Mounting

- **Material:** Aluminium
- **Finish/colour:** Silver coloured anodized
- **Length x Width:** 2500 x 18 mm
- **Height:** 13 mm
- **Supplied with:** 1 profile, 1 diffuser

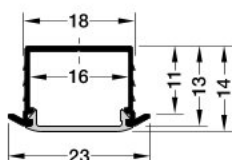

+ End cap with cable outlet for 833.72.846

- **Material:** Plastic
- **Supplied with:** 2 pieces

ORDERING INFORMATION

	Colour	Article No.
1	Silver coloured with milky diffuser	833.72.846
	Description	Silver coloured
1	End cap with cable outlet for 833.72.846	833.72.854



Profiles for Recess Mounting Aluminium

Häfele Loox5 profile 1107 / 1106



- **Material:** Profile: Aluminium, Diffuser: Plastic
- **Finish/colour:** Profile: Anodized, Diffuser: White opal, transmittance 70-80 %
- **Length:** 3000 mm
- **Diffuser width:** Profile 1107: 8 mm, Profile 1106: 11 mm
- **Supplied with:** 1 aluminium profile
1 diffuser white opal



End caps for Häfele Loox5 profile 1106

- **Material:** Plastic
- **Version:** With cable outlet
- **Mounting:** For screw fixing
- **Supplied with:** 5 pairs of end caps with screws

Häfele Loox5 profile 1107, with asymmetric light distribution

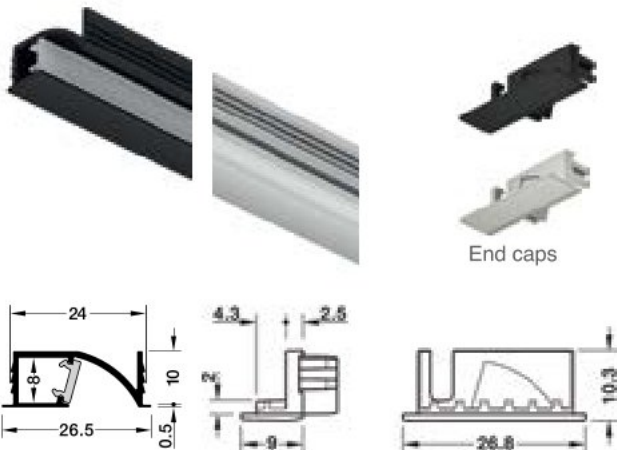

Häfele Loox5 profile 1106, with asymmetric light distribution

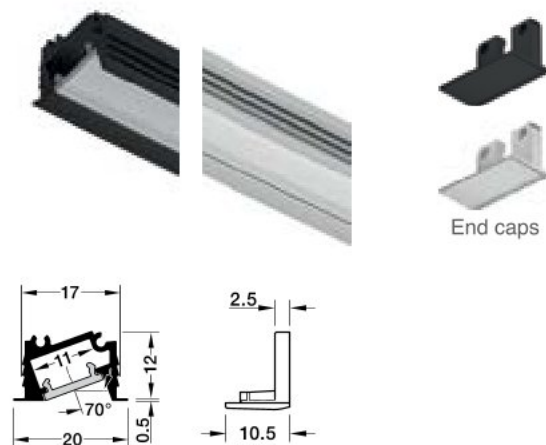

Diffusers

The diffuser creates a uniform light.
If required, please order alternative diffuser in black opal separately.

- Profile 1107 is usable for LED strip lights up to max. 5 mm width.
Glare-free light, ideal for vertical installation in wardrobes.

ORDERING INFORMATION

	Colour	Profile 1107	Profile 1106
1	Black	833.95.731	833.95.729
2	Silver coloured	833.95.730	833.95.728
	Description	Black	Silver coloured
1	End caps for Häfele Loox5 profile 1107	833.95.820	833.95.821
2	End caps for Häfele Loox5 profile 1106	833.95.773	833.95.772

Profiles for Recess Mounting Poly-carbonate

Häfele Loox5 profile 1102 / 1101

- **Material:** Poly-carbonate
- **Finish/colour:** White & Black opal
- **Length:** 3000 mm
- **Supplied with:** 1 Poly-carbonate profile



Häfele Loox5 profile 1102



Häfele Loox5 profile 1101

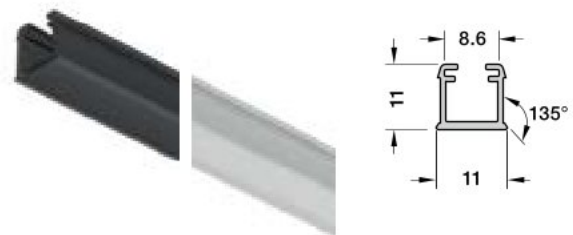

Note

- ! Profiles 1102 and 1101 are usable for LED strip lights up to max.9.6 W/m.
- Profile 1102 is usable for LED strip lights up to max. 5 mm width.
- Profile 1101 is usable only for LED strip lights with a width of precisely 8 mm.
- The diffuser creates a uniform light.
- The LED points in the white version are invisible from 120 LEDs/m.

ORDERING INFORMATION

	Colour	Transmittance	Profile 1102	Profile 1101
1	Black	~20 %	833.95.741	833.72.899
2	White	70-80 %	833.95.740	833.72.898



Profiles for Surface Mounting Aluminium

Häfele Loox5 profile 2102



- **Material:** Profile: Aluminium, Diffuser: Plastic
- **Finish/colour:** Profile: Anodized, Diffuser: White opal, transmittance 70-80 %
- **Length:** 3000 mm
- **Diffuser width:** 11 mm
- **Supplied with:** 1 aluminium profile
1 diffuser white opal

- +** End caps for Häfele Loox5 profile 2102
- **Material:** Plastic
 - **Version:** With drill mark for cable outlet
 - **Supplied with:** 5 pairs of end caps

! The diffuser creates a uniform light. The LED points are invisible from 120 LEDs/m. If required, please order alternative diffuser in black opal separately.

Adhesive tape for Häfele Loox5 profile 2102

- **Area of application:** For fixing aluminium on wood, metals, or plastics
- **Version:** Double-sided, high instant adhesion, high temperature resistance
- **Length:** 33 m
- **Width:** 10 mm
- **Thickness:** 0.6 mm



Häfele Loox5 profile 2102



ORDERING INFORMATION

	Colour	Profile 2102
1	Black	833.95.735
2	Brushed stainless steel coloured	833.95.763

End caps for Häfele Loox5 profile 2102

	Colour	End cap 2102
1	Black	833.95.778
2	Silver coloured	833.95.779

Adhesive tape for Häfele Loox5 profile 2102

	Article No.
Adhesive tape	833.89.266

Profiles for Surface Mounting

Aluminium

Häfele Loox5 profile 2104, with concealed fixing

- **Material:** Profile: Aluminium, Diffuser: Plastic
- **Finish/colour:** Profile: Anodized, Diffuser: White opal, transmittance 70-80 %
- **Length:** 3000 mm
- **Diffuser width:** 11 mm
- **Supplied with:** 1 aluminium profile
1 diffuser white opal



Häfele Loox5 profile 2104, with asymmetric light distribution

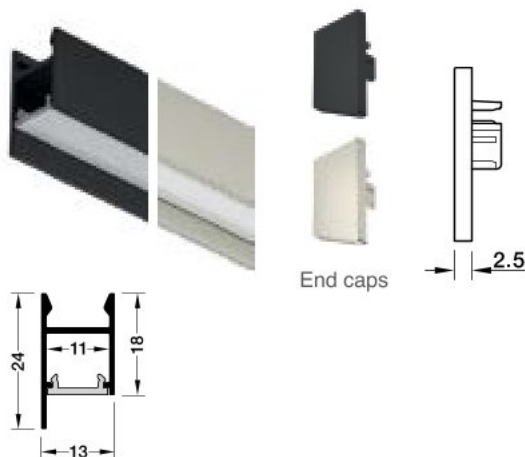

- **The diffuser creates a uniform light.**
The LED points are invisible from 120 LEDs/m. If required, please order alternative diffuser in black opal separately.

End caps for Häfele Loox5 profile 2104

- **Material:** Plastic
- **Version:** With drill mark for cable outlet
- **Supplied with:** 5 pairs of end caps

Order reference

Please order (mandatory) mounting bracket separately.

Mounting bracket

- **Material:** Stainless steel
- **Mounting:** For screw fixing
- **Supplied with:** 5 pairs of mounting brackets

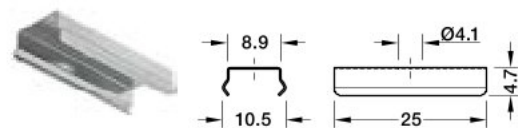

Mounting bracket for concealed fixing

ORDERING INFORMATION

	Colour	Profile 2104
1	Black	833.95.739
2	Brushed stainless steel coloured	833.95.765

End caps for Häfele Loox5 profile 2104		
	Colour	End cap 2104
1	Black	833.95.784
2	Silver coloured	833.95.785

	Article No.
Mounting bracket	833.95.761



Profiles for Surface Mounting

Aluminium

Häfele Loox profile for surface mounting

- **Material:** Aluminium
- **Finish/colour:** Silver coloured anodized
- **Length x width:** 2500 x 18 mm
- **Height:** 9.5 mm
- **Supplied with:** 1 profile, 1 diffuser

Note
LED points are always visible when this profile is used.
Permanent operation (≥8 hours/day) only with LED strip lights up to 9.6 W/m.

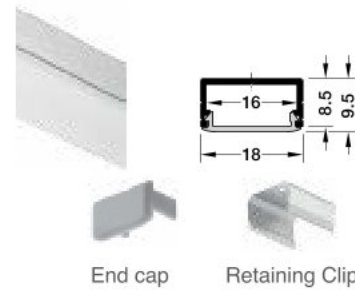

- +** **End cap for 833.72.840**
 - **Material:** Plastic, silver coloured
 - **Supplied with:** 2 pieces
- Retaining clip for 833.72.840**
 - **Material:** Stainless steel, silver coloured
 - **Supplied with:** 2 pieces

ORDERING INFORMATION

Colour	Article No.
1 Silver coloured with milky diffuser	833.72.840
End caps for 833.72.840	
Silver coloured	833.72.852
Retaining clip for 833.72.840	833.74.832

- **Material:** Aluminium
- **Finish/colour:** Silver coloured anodized
- **Length x width:** 2500 x 18 mm
- **Height:** 14 mm
- **Supplied with:** 1 profile, 1 diffuser

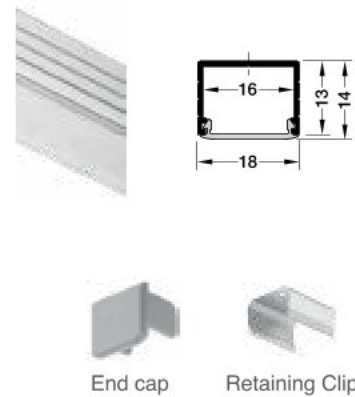

- +** **End cap for 833.72.841**
 - **Material:** Plastic, silver coloured
 - **Supplied with:** 2 pieces
- Retaining clip for 833.72.841**
 - **Material:** Stainless steel, silver coloured
 - **Supplied with:** 2 pieces

ORDERING INFORMATION

Colour	Article No.
1 Silver coloured with milky diffuser	833.72.841
End caps for 833.72.841	
Silver coloured	833.72.853
Retaining clip for 833.72.841	833.74.832

Profiles for Surface Mounting

Aluminium

Häfele Loox corner profile

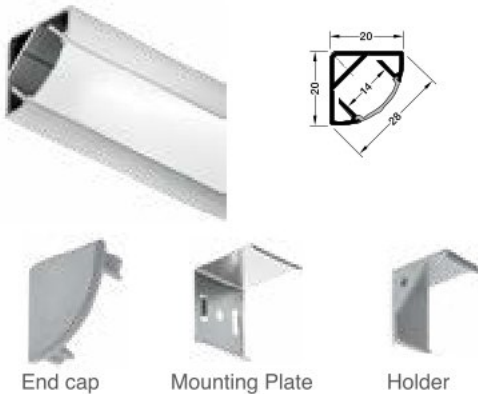

- **Material:** Aluminium
- **Finish/colour:** **Profile:** Silver coloured anodized
Diffuser: Milky
- **Length x width:** 2500 x 28 mm
- **Height:** 20 mm
- **Supplied with:** 1 aluminium profile
1 diffuser milky

- + End cap and holder/ mounting plate**
- **Material:** **End cap and holder:** Plastic, silver coloured
Mounting plate: Stainless steel
 - **Supplied with:** 2 pieces

ORDERING INFORMATION

Colour	Article No.
Silver coloured	833.74.812
	Article No.
End cap	833.74.822
Holder	833.74.825
Mounting plate	833.74.826

Häfele Loox corner profile 7106



- **Material:** **Profile:** Aluminium, **Diffuser:** Plastic
- **Finish/ colour:** **Profile:** Silver and black
Diffuser: White opal
- **Length x width:** 2500 mm x 20.5 mm
- **Height:** 15 mm
- **Application:** In cove/ niche applications,
Under overhead kitchen cabinets and inside wardrobes/ cabinets
- **Mounting:** Surface mounted
- **Diffuser details:** Flat diffuser with no protrusion
Easy to Clean
Transmittance 70-80%
- **Supplied with:** 1 Aluminium profile
1 Diffuser

- + End cap**
- **Material:** Plastic
 - **Finish/ Colour:** Silver and black
 - **Supplied with:** 2 pieces
- Mounting bracket**
- **Material:** Stainless steel
 - **Finish/ Colour:** Stainless steel
 - **Supplied with:** 2 pieces

ORDERING INFORMATION

Colour	Article No.	
Silver	833.16.181	
Black	833.16.180	
Description	Finish	Article No.
End Cap for Corner Profile	Silver	833.01.930
End Cap for Corner Profile	Black	833.01.931
Mounting Bracket for Corner Profile	Stainless Steel	833.01.932



Profiles for surface mounting

Aluminium

Häfele Loox surface angular profile 7107

- **Material:** Profile: Aluminium, Diffuser: Plastic
- **Finish/ colour:** Profile: Silver and black
Diffuser: White opal
- **Length x width:** 2500 mm x 21 mm
- **Height:** 11 mm
- **Application:** Under overhead cabinets in kitchens, Wardrobe shelves and wardrobe side panels
- **Mounting:** Surface mounted
- **Diffuser details:** Flat diffuser with no protrusion
Easy to clean
Transmittance 70-80%
- **Supplied with:** 1 Aluminium profile
1 Diffuser

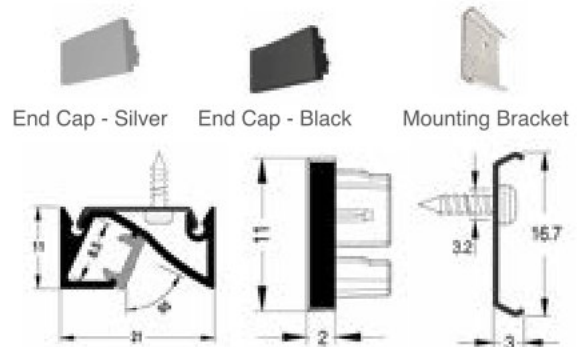
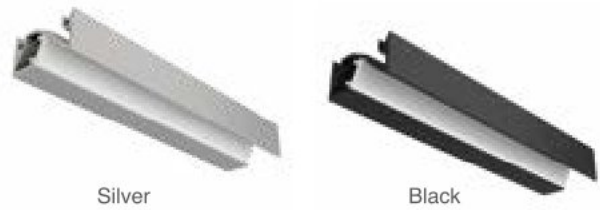

End cap

- **Material:** Plastic
- **Finish/ Colour:** Silver and black
- **Supplied with:** 2 pieces

Mounting bracket

- **Material:** Stainless steel
- **Finish/ Colour:** Stainless steel
- **Supplied with:** 2 pieces

ORDERING INFORMATION

Colour	Article No.
Silver	833.16.173
Black	833.16.172

Description	Finish	Article No.
End Cap for Surface Angular Profile	Silver	833.01.933
End Cap for Surface Angular Profile	Black	833.01.934
Mounting Bracket for Surface Angular Profile	Stainless Steel	833.01.935

Häfele Loox drawer profile

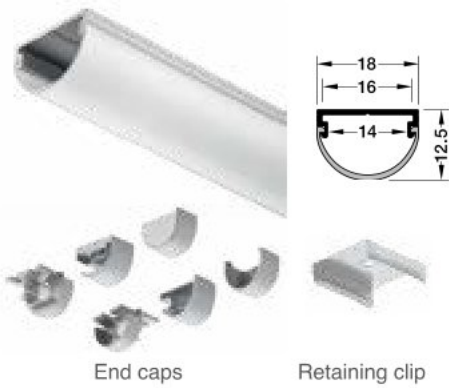

- **Material:** Aluminium
- **Finish/colour:** Profile: Silver coloured anodized
Diffuser: Milky
- **Length x width:** 2500 x 18 mm
- **Height:** 12.5 mm
- **Supplied with:** 1 aluminium profile
1 diffuser milky

+ **End cap set**

- **Material:** ABS plastic, silver coloured
- **Supplied with:** 5 sets of end caps, fixing screws

Retaining clip

- **Material:** Stainless steel, silver coloured
- **Supplied with:** 2 pieces

Häfele Loox drawer profile: Door sensors

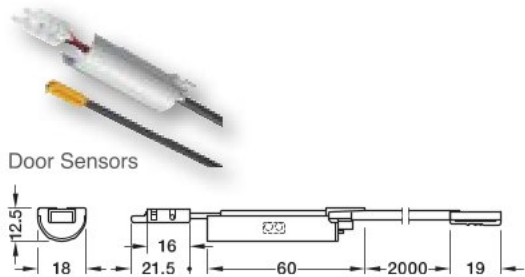

Häfele Loox drawer profile: Door sensors

- **Suitable for:** Häfele Loox drawer profile
- **Clip connector** Loox5 LED strip light 8 mm monochrome type:
- **Material:** Plastic
- **Installation:** For plug fitting, For screw fitting

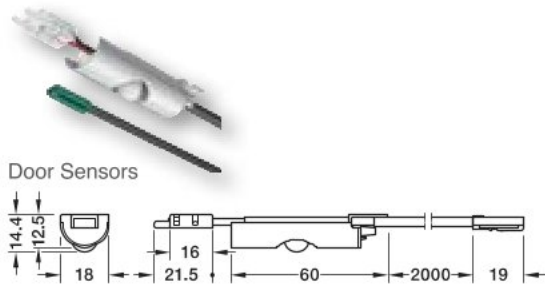

- **Suitable for:** Häfele Loox drawer profile
- **Clip connector** Loox5 LED strip light 8 mm monochrome type:
- **Material:** Plastic
- **Sensor range:** 0-3000mm
- **Delay time:** 30-30s
- **Installation:** For plug fitting, For screw fitting

ORDERING INFORMATION

Colour		Article No.
Silver coloured		833.74.835
Description		Article No.
End cap set		833.74.877
Retaining clip		833.74.893
Häfele Loox drawer profile: Door sensors		
	Switching capacity W	Article No.
5 12V	60	833.89.251
5 24V	90	833.89.254

Packing: 1, 10 or 50 Pieces



Profiles

Aluminium

Häfele Loox wardrobe rail, asymmetric light distribution

- **Material:** Aluminium
- **Finish/colour:** Profile: Silver coloured anodized
Diffuser: Milky
- **Length x width:** 2500 x 15 mm
- **Height:** 30 mm
- **Supplied with:** 1 aluminium profile
1 diffuser milky



Rail end support, side panel



Wardrobe rail, rail centre support



! LED points are always visible when this profile is used.



Rail end support, side panel

- **Material:** Zinc alloy
- **Mounting:** For screw fixing to side panel
- **Supplied with:** 1 piece

Rail centre support, wardrobe rail

- **Material:** Zinc alloy, chrome plated
- **Mounting:** For screw fixing
- **Supplied with:** 1 piece

ORDERING INFORMATION

Colour	Article No.
Silver coloured	833.72.790
	Article No.
Rail end support, side panel	803.33.757
Wardrobe rail, rail centre support	802.07.200

Häfele two way aluminium profile

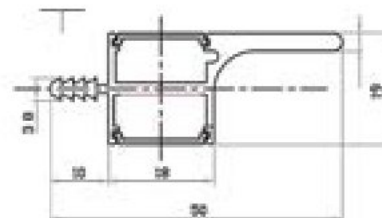
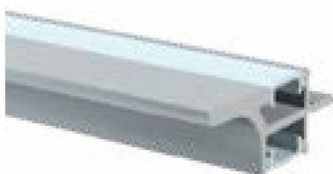

- **Material:** Aluminium
- **Finish/colour:** Silver coloured anodized
Diffuser: Milky
- **Length x width:** 2500 x 50 mm
- **Height:** 19 mm

ORDERING INFORMATION

Colour	Article No.
Silver coloured	833.01.720



Sensors Switch

TOUCHLESS

Häfele Loox sensor switch, modular – touchless, soft on/off switching

- **Material:** Plastic
- **Degree of protection:** IP20
- **Sensor range:** 0 - 80 mm
- **Power consumption:** ≤0.3 W
- **Drill hole Ø:** 12 mm
- **Supplied with:** 1 switch

- ⊕ Please order lead with snap-in connector for modular switches separately. Length 2m: Article. No. 833.89.142. See page 313
- ! On/off state is stored without the need for power supply (memory function).

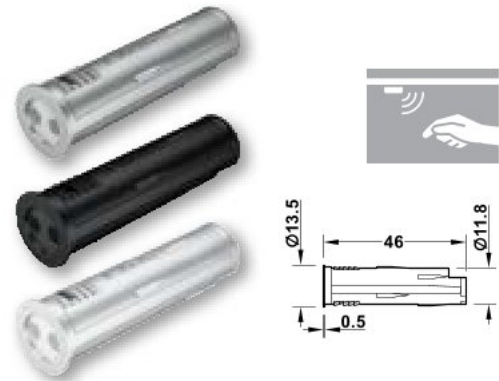

	Article. No.
Silver coloured	833.89.127
Black	833.89.167
White	833.89.169

Häfele Loox door sensor switch, modular – soft on/off switching

- **Material:** Plastic
- **Degree of protection:** IP20
- **Sensor range:** 0 – 100 mm
- **Power consumption:** ≤0.3 W
- **Drill hole Ø:** 12 mm
- **Supplied with:** 1 switch

- ⊕ Please order lead with snap-in connector for modular switches separately. Length 2m: Article. No. 833.89.142. See page 313

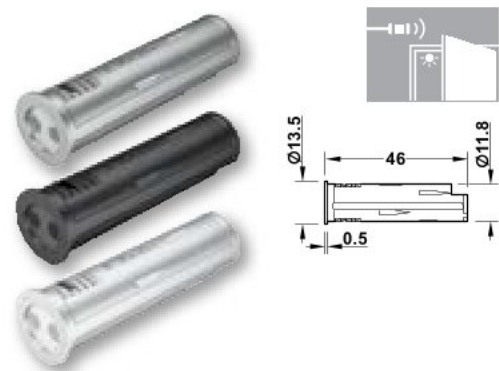

	Article. No.
Silver coloured	833.89.128
Black	833.89.170
White	833.89.171

Häfele Loox motion detector, modular – automatic on/off switching

- **Material:** Plastic, silver coloured
- **Degree of protection:** IP20
- **Sensor range:** 0 - 3000 mm
- **Sensor angle:** 120° mm
- **Power consumption:** ≤0.1 W
- **Drill hole Ø:** 12 mm
- **Supplied with:** 1 switch

- ⊕ Please order lead with snap-in connector for modular switches separately. Length 2m: Article. No. 833.89.142. See page 313

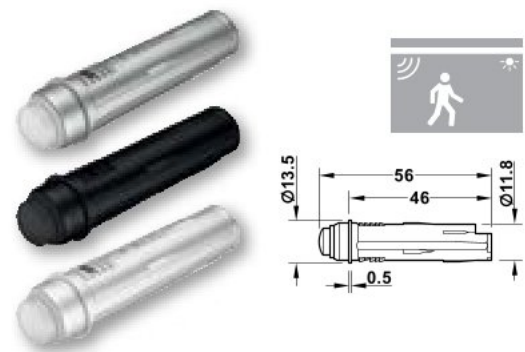

	Delay Time	Article. No.
Silver coloured	30	833.89.129
Black	30	833.89.172
White	30	833.89.173

Häfele Loox dimmer, modular – automatic on/off switching

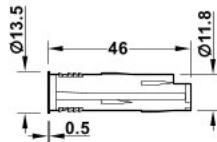

- **Material:** Plastic
- **Degree of protection:** IP20
- **Power consumption:** ≤0.3 W
- **Drill hole Ø:** 12 mm
- **Supplied with:** 1 dimmer

WITH CONTACT/
TOUCHLESS

- ⊕ Please order lead with snap-in connector for modular switches separately. Length 2m: Article. No. 833.89.142. See page 313
- ! Dimming value is stored without the need for voltage supply (memory function).

ORDERING INFORMATION

	Sensor Range	Article. No.
With touch		
Silver coloured	-	833.89.058
Black	-	833.89.174
White	-	833.89.175
Touchless		
Silver coloured	0-60 mm	833.89.126
Black	0-60 mm	833.89.166
White	0-60 mm	833.89.168

Häfele Loox capacitive switch/dimmer, modular – touchless on/off switching and dimming



This completely invisible operating solution opens up completely new possibilities in continuously adjustable light control.

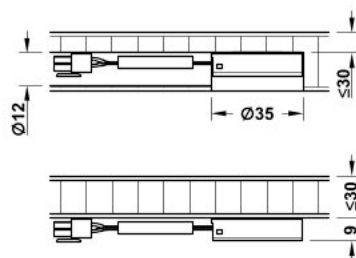

- Manual operation (proximity sensor), memory function
- Concealed installation in wood, glass or stone (not in metalliferous materials) at a maximum depth of 30 mm
- For screw fixing or recess mounting (drill hole Ø 35 mm)
- A distance of min. 500 mm to electromagnetic fields (power lines, microwave) must be adhered to.

- **Material/colour:** Plastic, silver coloured
- **Diameter:** 35 mm
- **Height:** 10 mm
- **Degree of protection:** IP20
- **Power consumption:** ≤1 W
- **Supplied with:** 1 switch

- ⊕ Please order lead with snap-in connector for modular switches driver separately. Length 2m: Article No. 833.89.142. See page 313

ORDERING INFORMATION

	Article No.
Capacitive switch/dimmer, modular	833.89.133



Häfele Loox dimmer, surface mounted modular – soft on/off switching and dimming

WITH TOUCH



With touch function

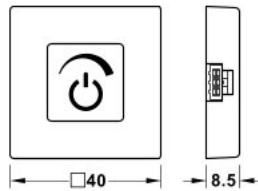

- **Material/colour:** Plastic, silver coloured
- **Dimension:** 40 x 40 x 8.5 mm (L x W x H)
- **Degree of protection:** IP20
- **Sensor range:** 0–100 mm
- **Power consumption:** ≤0.3 W
- **Supplied with:** 1 switch with fixing material

ORDERING INFORMATION

	Article No.
Modular dimmer (with touch)	833.89.134

⊕ Please order lead with snap-in connector for modular switches driver separately. Length 2 m: Article No. 833.89.142. See page 313

! Dimming value is stored without the need for voltage supply (memory function)

Switch Housing

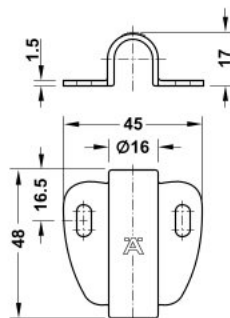

- **Application:** For switch with Ø 12 mm
- **Finish:** Plastic, silver coloured
- **Supplied with:** 1 housing

ORDERING INFORMATION

Diameter (mm)	Width (mm)	Height (mm)	Length (mm)	Article No.
16	45	17	48	833.89.090

Häfele Loox lead for modular switches



- **Area of application:** Modular switches
- **Version:** With snap-in connector
- **Drill hole Ø:** Plug 12 mm
- **Supplied with:** 1 lead plug/plug

ORDERING INFORMATION

Length mm	Article No.
1000	833.89.141
2000	833.89.142

Switch leads

Häfele Loox extension lead for switches



- **Area of application:** Switches and modular switches
- **Length:** 2000 mm
- **Drill hole Ø:** Plug 12 mm
- **Supplied with:** 1 extension lead plug/socket

ORDERING INFORMATION

Length mm	Article No.
2000	833.89.067

! The maximum lead length of a switch is 6 m.

Häfele Connect Mesh Box



Häfele Connect Mesh 6-way distributor, with switching function

- Control several light colors on one box!
- Each output port can be controlled individually.

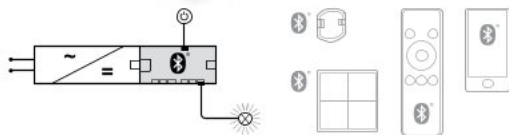

- **Area of application:** For on/off switching and dimming (0-100%) of monochrome lights; or, in conjunction with adapters, for the operation of multi-white lights, RGB lights, and electrically operated fittings (With programmable switching input for standard Loox switches (switching function programmable via app; each active component can control each passive component))
- **Version:**
- **Material:** Plastic
- **Colour:** Black
- **Dim. (L x W x H):** 120 x 50 x 16 mm
- **Number of connections:** 1x input port with box to box plug
1x output port with box to box socket
1x input port switch socket
6x output ports device sockets (2-pin) can be controlled from any active component of the network <0.5 W
- **Standby power consumption:**
- **Supplied with:** 1 distributor



Häfele Connect Mesh App

- > Detects and reports new nodes in the network independently
- > Intuitively assign functions to switches
- > Set up light groups and scenes
- > Share your protected access with others
- > The Häfele Connect Mesh App is free for Apple iOS® and Android™.



! Range of smartphone or tablet to nearest Häfele Connect Mesh component approx. 10 m. The distance within the network applies in the event of a clear view. Obstacles and electromagnetic interference sources can reduce the range. Another 6-way distributor can be used as a signal amplifier to compensate for the loss of range.

- +** Please order adapters for multi-white lights, RGB lights or electrically operated fittings separately, see page 315
- ➔** 6-way distributor for monochrome lights or other 2-pin devices, such as electrically operated fittings, see page 315

	Voltage	Max. connected wattage W	Article No.
Monochrome	5 12V	60	850.00.042
	5 24V	120	850.00.043

Adapter

Häfele Loox5 6-way distributor without switching function



Can also be connected to 6-way distributor

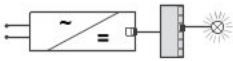

The Loox5 6-way Distributor can be connected to the Connect Mesh Box to provide extra number of output ports for monochrome lights.

- **Material:** Plastic
- **Colour:** Black
- **Dim. (L x W x H):** 70 x 30 x 14 mm
- **Number of connections:** 1 x input port with plug, monochrome 6 x output ports device sockets
- **Supplied with:** 1 distributor

Voltage V	Max. connected wattage W	Without switching function
5 12V	60	833.95.786
5 24V	120	833.77.839

Häfele Loox5 multi-white adapter for Häfele Connect Mesh 6-way distributor

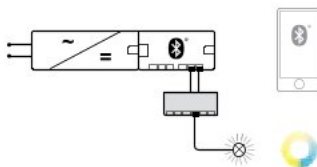

1 multi-white adapter occupies 2 output ports at the 6-way distributor.

- **Area of application:** For connecting multi-white lights to the Häfele Connect Mesh 6-way distributor
- **Material/colour:** Plastic, black
- **Dim. (L x W x H):** 70 x 30 x 14 mm
- **Number of connections:** 2x input port with plug, monochrome 6x output ports device sockets, multi-white
- **Supplied with:** 1 distributor with 80 mm lead

Voltage V	Max. connected wattage W	Article No.
5 12V	60	833.95.745
5 24V	120	833.77.830

Häfele Loox5 RGB adapter for Häfele Connect Mesh 6-way distributor

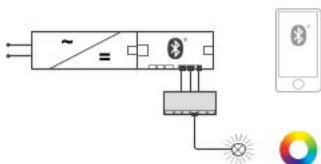
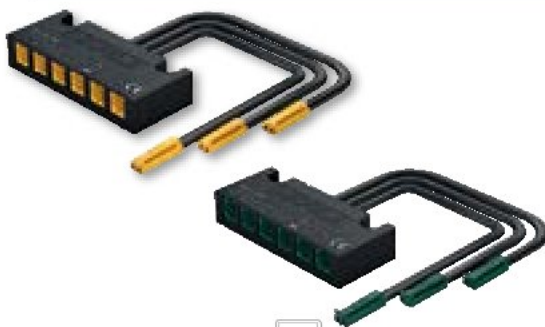

1 RGB adapter occupies 3 output ports at the 6-way distributor.

- **Area of application:** For connecting RGB lights to the Häfele Connect Mesh 6-way distributor
- **Material/colour:** Plastic, black
- **Dim. (L x W x H):** 70 x 30 x 14 mm
- **Number of connections:** 3x input port with plug, monochrome 6 x output ports for device sockets, RGB
- **Supplied with:** 1 distributor with 80 mm lead

Voltage V	Max. connected wattage W	Article No.
5 12V	60	833.95.746
5 24V	120	833.77.831

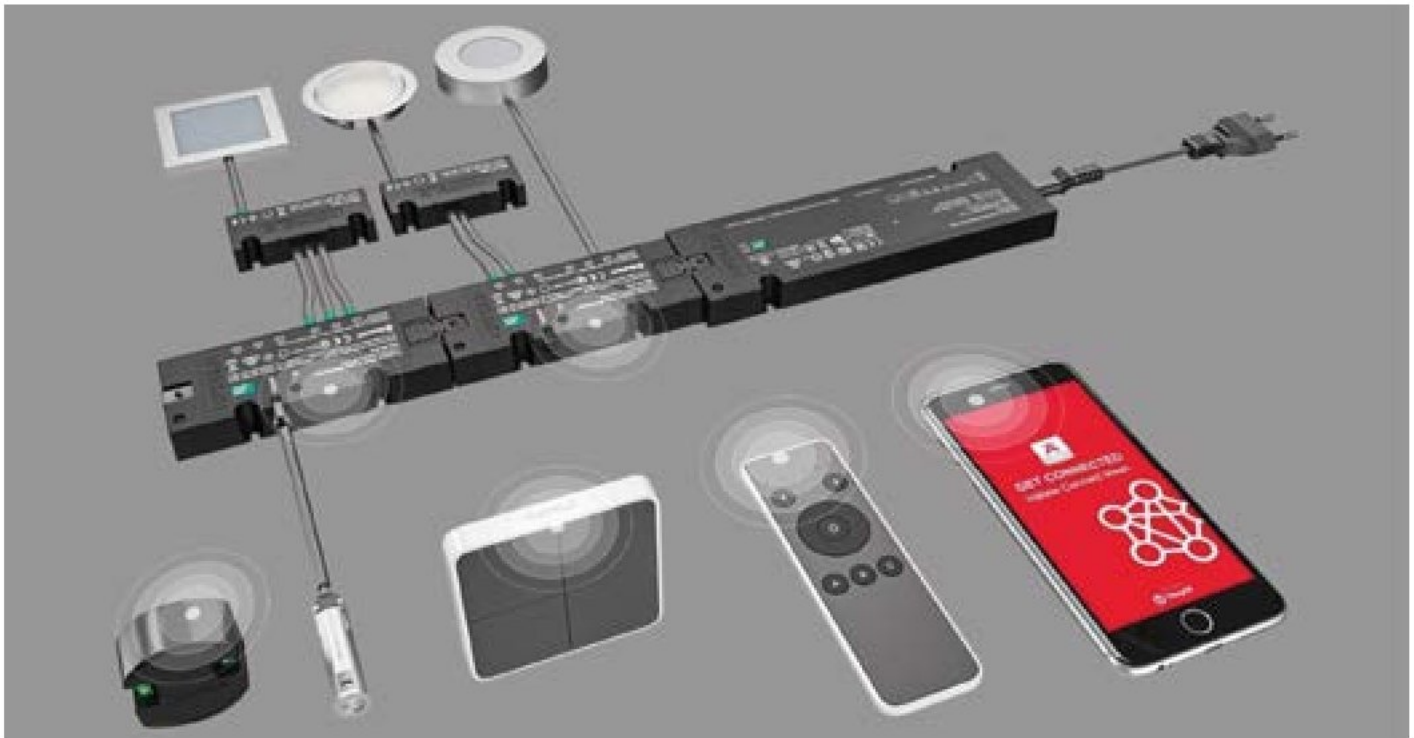

CONTROLS

 Häfele Connect Mesh remote control

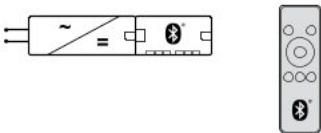

Easiness

- One remote control for all applications: monochrome lights, multi-white lights, RGB lights and electrically operated fittings
- **Area of application:** For controlling Häfele Connect Mesh components in a network
- **Configuration:** Easy, direct pairing with a 6-way distributor or programming of buttons via app to control each node of the network
- **Version:** Multi-function control panel
- **Material:** Plastic
- **Colour:** Top shell: black, lower shell: white
- **Dim. (L x W x H):** 130 x 42 x 11 mm
- **Battery service life:** 3,600 duty cycles
- **Supplied with:** 1 remote control

	Article No.
Remote control	850.00.040

 Häfele Connect Mesh push button, wall mounted

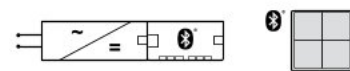

- **Area of application:** For controlling Häfele Connect Mesh components in a network (all functions which are possible by pressing or holding down a key)
- **Configuration:** Easy, direct pairing with a 6-way distributor or programming of buttons via app to control each node of the network
- **Version:** 4-button panel
- **Material:** Plastic
- **Colour:** Pushbutton: black, frame: white
- **Dim. (L x W x H):** 81 x 81 x 12 mm
- **Mounting:** For screw fixing or glue fixing to any wall
- **Battery service life:** 1,800 duty cycles
- **Supplied with:** 1 push button, wall mounted

	Article No.
Wall mounted push button	850.00.041

 Please order Häfele Connect Mesh 6-way distributor separately
Please order 1 lithium button cell battery CR2430 separately.

Leads

For LED strip light monochrome, 5 mm

Häfele Loox5 lead for LED strip light monochrome, 5 mm

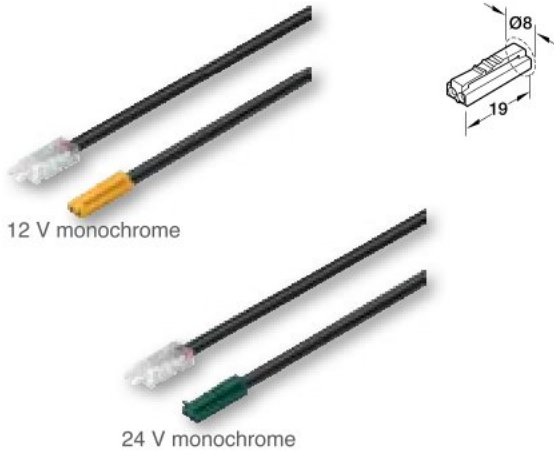

- **Current carrying capacity:** Max. 3.5 A
- **Width:** Clip 7 mm
- **Drill hole Ø:** Plug 8 mm
- **Supplied with:** 1 lead plug/clip

Type of cable	Voltage V	Length mm	Article No.
Monochrome (2-wire 20 AWG)	5 12V	2000	833.95.705
	5 24V	2000	833.95.711

Häfele Loox5 interconnecting lead for LED strip light monochrome, 5 mm



- **Current carrying capacity:** Max. 3.5 A
- **Width:** Clip 7 mm
- **Drill hole Ø:** Clip 10 mm
- **Supplied with:** 1 interconnecting lead clip/clip

Type of cable	Length mm	Article No.
Monochrome (2-wire 20 AWG)	500	833.89.195

Häfele Loox5 clip connector for LED strip light monochrome, 5 mm



- **Current carrying capacity:** Max. 3.5 A
- **Width:** Clip 7 mm
- **Drill hole Ø:** Clip 10 mm
- **Supplied with:** 10 clip connector

Length mm	Article No.
33.5	833.89.207

Häfele Loox5 corner connector for LED strip light monochrome, 5 mm



- **Current carrying capacity:** Max. 3.5 A
- **Supplied with:** 10 corner connectors

Length mm	Width mm	Article No.
21	21	833.89.190



Leads

For LED strip light monochrome, 8 mm

Häfele Loox5 lead for LED strip light monochrome, 8 mm

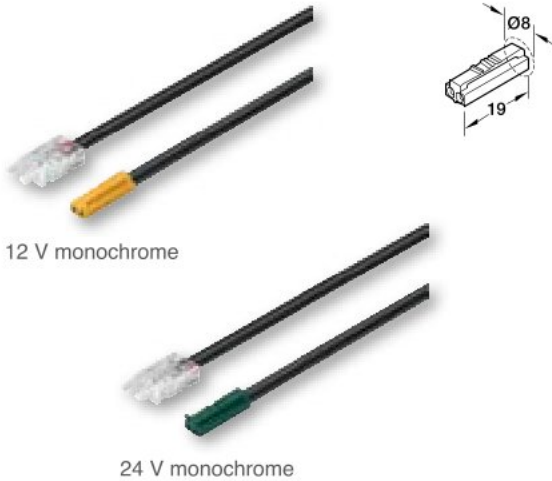

12 V monochrome

24 V monochrome

- **Current carrying capacity:** Max. 5 A
- **Width:** Clip 10 mm
- **Drill hole Ø:** Plug 8 mm
- **Supplied with:** 1 lead plug/clip

Type of cable	Voltage V	Length mm	Article No.
Monochrome (2-wire 18 AWG)	5 12V	2000	833.95.700
	5 24V	2000	833.95.706

Häfele Loox5 interconnecting lead for LED strip light monochrome, 8 mm

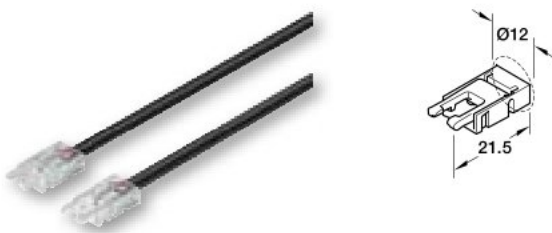

- **Current carrying capacity:** Max. 5 A
- **Width:** Clip 10 mm
- **Drill hole Ø:** Clip 12 mm
- **Supplied with:** 1 lead clip/clip

Type of cable	Length mm	Article No.
Monochrome (2-wire 18 AWG)	500	833.89.192

Häfele Loox5 clip connector for LED strip light monochrome, 8 mm



- **Current carrying capacity:** Max. 5 A
- **Width:** Clip 10 mm
- **Drill hole Ø:** Clip 12 mm
- **Supplied with:** 10 clip connector

Length mm	Article No.
33.5	833.89.206

Häfele Loox5 corner connector for LED strip light monochrome, 8 mm



- **Current carrying capacity:** Max. 5 A
- **Supplied with:** 10 corner connectors

Length mm	Width mm	Article No.
24	24	833.89.187

Leads

For LED silicone strip light monochrome, 8 mm

Häfele Loox5 IP44 lead for LED silicone strip light, monochrome 8 mm



24 V monochrome

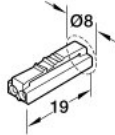

- **Current carrying capacity:** Max. 5 A
- **Width:** Silicone plug 15 mm
- **Drill hole Ø:** Plug 8 mm
- **Supplied with:** 1 lead plug/clip

Type of cable	Voltage V	Length mm	Article No.
Monochrome (2-wire 18 AWG)	5 ^{24 V}	2000	833.95.709

Häfele Loox5 IP44 interconnecting lead for LED silicone strip light, monochrome 8 mm

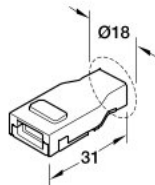

- **Current carrying capacity:** Max. 5 A
- **Width:** Clip 15 mm
- **Drill hole Ø:** Clamp 18 mm
- **Supplied with:** 1 lead clip/clip

Type of cable	Length mm	Article No.
Monochrome (2-wire 18 AWG)	2000	833.95.205

- ➔ Connections with degree of protection IP20 can be established with leads and clips from page 318 for the monochrome silicone strip light 8 mm.

Leads

For LED strip light RGB, 10 m



Häfele Loox5 lead for LED strip light RGB, 10 mm



24 V RGB

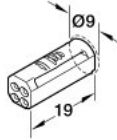

- **Current carrying capacity:** Max. 3.5 A
- **Width:** Clip 12 mm
- **Drill hole Ø:** Plug 9 mm
- **Supplied with:** 1 lead plug/clip

Type of cable	Voltage V	Length mm	Article No.
RGB (4-wire 20 AWG)	5 ^{24 V}	2000	833.95.710

Häfele Loox5 interconnecting lead for LED strip light RGB, 10 mm

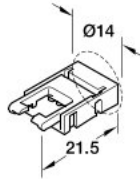

- **Current carrying capacity:** Max. 3.5 A
- **Width:** Clip 12 mm
- **Drill hole Ø:** Clip 14 mm
- **Supplied with:** 1 lead clip/clip

Type of cable	Length mm	Article No.
RGB (4-wire 20 AWG)	500	833.89.201

Häfele Loox5 clip connector for LED strip light RGB, 10 mm

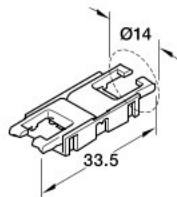

- **Current carrying capacity:** Max. 3.5 A
- **Width:** Clip 12 mm
- **Drill hole Ø:** Clip 14 mm
- **Supplied with:** 10 clip connector

Length mm	Article No.
33.5	833.89.209

Häfele Loox5 corner connector for LED strip light RGB, 10 mm



- **Current carrying capacity:** Max. 3.5 A
- **Supplied with:** 10 corner connectors

Length mm	Width mm	Article No.
26	26	833.89.189

Adapter

Loox driver > Loox5 device

Adapter for devices with Loox5 plug for connecting to Loox driver



12 V: Loox5 socket/Loox plug



24 V: Loox5 socket/Loox plug

- **Area of application:** For connecting Loox5 devices to Loox drivers or Loox distributors. Suitable for all devices with 2-pin Loox5 plug, e.g. monochrome lights, distributors, charging stations, etc.
- **Length:** 45 mm
- **Current carrying capacity:** Max. 3.5 A
- **Drill hole Ø:** 13 mm
- **Packing:** 6 piece

Device	Power supply unit	Max. connected wattage W	Article No.
5 12V	12V	max. 42	833.95.752
5 24V	24V	max. 84	833.77.837

! Not suitable for 4-pin Loox5 plugs (multi-white or RGB). The current carrying capacity is limited to 3.5 A. Observe maximum wattage!

Adapter leads for LED strip lights with Loox5 clip for connecting to Loox driver or colour mixer

Device	Power supply unit	Length mm	For LED strip light	Article No.
5 12V	12V	2000	monochrome 5 mm monochrome 8 mm	833.72.742 833.72.716
5 24V	24V	2000		833.75.705

Adapter

Loox5 driver > Loox5 device

Adapter for devices with Loox plug for connecting to Loox5 driver



12 V: Loox socket/Loox5 plug



24 V: Loox socket/Loox5 plug

- **Area of application:** For connecting Loox devices to Loox5 drivers or Loox5 distributors. Suitable for all devices with Loox plug, e.g. monochrome lights, distributors, charging stations, colour mixers for multi-white and RGB as well as electrically operated fittings, converters, etc.
- **Length:** 50 mm
- **Current carrying capacity:** Max. 3.5 AA
- **Drill hole Ø:** 12 mm
- **Packing:** 6 piece

Device	Power supply unit	Max. connected wattage W	Article No.
12V	5 12V	max. 42	833.95.753
24V	5 24V	max. 84	833.77.838

! Not suitable for 3-pin Loox plugs (multi-white) or 4-pin Loox plugs (RGB).
The current carrying capacity is limited to 3.5 A.
Observe maximum wattage!

Leads and Distributors

Extension leads 12 V / 24 V / 350 mA



- **Supplied with:** 1 lead

Application	Length	
	1000 mm	2000 mm
12 V system, 3.5 A/20 AWG	833.73.765	833.73.766
24 V system, 3.5 A/20 AWG	833.77.713	833.77.714
350 mA system	833.80.705	833.80.706

- ! For extending the connection leads of the LED lights.
 - Lead length from driver to light max. 6 m

6-way distributor – for connecting additional lights to one driver

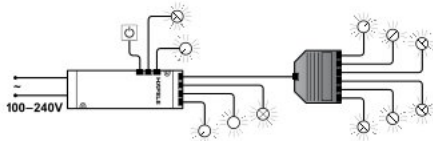

- **Length xWidth:** 58.5 x 34 mm
- **Height:** 18 mm
- **Supplied with:** 1 distributor with 2 m lead

Application	Article No.
12 V system, 3.5 A/20 AWG	833.74.798
24 V system, 3.5 A/20 AWG	833.77.724

- ! With the 6-way distributor, up to 6 additional lights can be operated from one driver slot.

3-way distributor with switching function 12 V / 24 V

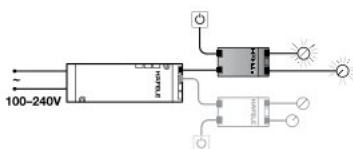

- **Length xWidth:** 57 x 34 mm
- **Height:** 18 mm
- **Supplied with:** 1 distributor with 200 m lead

Application	Wattage	Article No.
12 V system, 3.5 A/20 AWG	max. 42 W	833.74.751
24 V system, 3.5 A/20 AWG	max. 84 W	833.77.723

- ! Up to 3 lights can be operated independently of the driver using the 3-way distributor with switching function connected to the output of the light.

Converters

Häfele Loox converter 24 V to 12 V – for connecting 24 V lights to the 12 V system

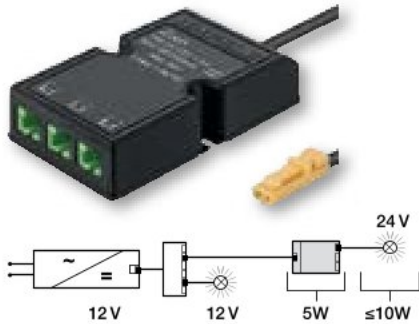

- **Application:** Connecting 24 V lights to the 12 V system
- **Wattage:** Input 15 W, output 10 W
- **Primary side:** DC 12 V
- **Secondary side:** DC 24 V
- **Number of output ports:** 3 connections for 24 V lights
- **Supplied with:** 1 converter with 200 mm lead

Dimensions (L x W x H) mm	Standby power consumption W	Article No.
61 x 34 x 15	0.3	833.77.934

12V 5 12V Loox5 12 V driver see page 296
Please order 6-piece adapter set 833.95.753 separately.

! Maximum possible connected rating of 10 W per converter.

Häfele Loox converter 12 V to 24 V – for connecting 12 V lights to the 24 V system

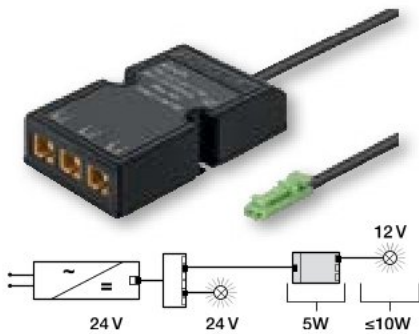

- **Application:** Connecting 12 V lights to the 24 V system
- **Wattage:** Input 15 W, output 10 W
- **Primary side:** DC 24 V
- **Secondary side:** DC 12 V
- **Number of output ports:** 3 connections for 12 V lights
- **Supplied with:** 1 converter with 200 mm lead

Dimensions (L x W x H) mm	Standby power consumption W	Article No.
61 x 34 x 15	0.3	833.74.947

24V 5 24V Loox5 24 V driver see page 297
Please order 6-piece adapter set 833.77.838 separately.

! Maximum possible connected rating of 10 W per converter.

KITCHEN SINKS & FAUCETS



Häfele's Range of Blanco Sinks comes with a unique colour fidelity and a host of contemporary colours, with identical surface conditions, specially designed to match the BLANCO taps

This section of the catalogue provides you with a detailed description of the features, product specifications and technical details of the models available in the range of BLANCO Kitchen Sinks and Mixer Taps



CombiColours

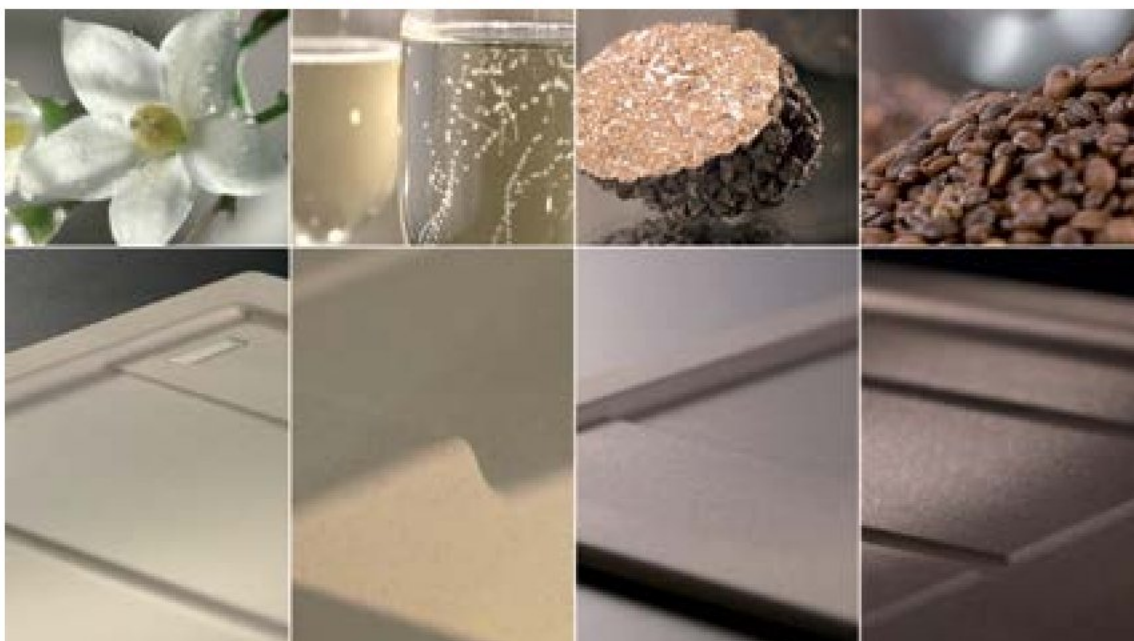

Häfele's range of BLANCO sinks are made of a patented material called SILGRANIT™ which offers an ease of care and level of resistance that has never been offered before for coloured composite sinks

SILGRANIT™ is a material that consists of 80% natural granite. The granite is combined with an acrylic matrix, ceramic and colour pigments to give it, its unbeatable characteristics. It combines the textural beauty of nature with unmatched strength and durability

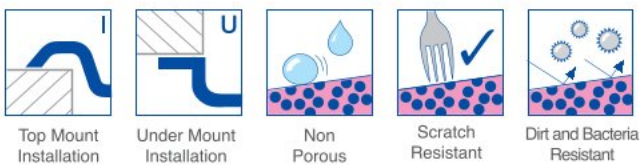

Material properties

The stony-silky surface and very finely pored, closed surface create a soft stonelike character that is wonderful to touch.

Unique colour fidelity

There is a choice of six delightful colours with the identical surface characteristics of the matching BLANCO taps.

Unbeatably easy to look after and long-lasting

Thanks to its excellent material properties SILGRANIT™ offers an ease of care and level of resistance that has never been offered before for coloured composite sinks.

- unsurpassed scratch resistance
- unsurpassed resistance to breakage
- unsurpassed heat-resistance to 280°C

Hygiene + Plus

SILGRANIT™ sinks include a patented hygiene protection formula: Hygiene+Plus.

Hygiene+Plus is a shield against dirt and bacteria, and makes cleaning easier. Tests confirm that this unique built-in hygiene protection reduces the growth of hygienically relevant bacteria by up to 98%

Häfele's range of BLANCO products have undergone the following quality and safety test:





SILGRANIT™ II
Unbeatable easy to look after and long-lasting. Thanks to the excellent material properties, SILGRANIT™ offers an ease of care and **level of resistance that has never been offered before** for coloured composite sinks.



Unsurpassed ease of cleaning

SILGRANIT™ is identified by its:

- outstanding ease of care
- superior durability
- patented hygiene protection formula



SILGRANIT™ is identified by its:

- 100% suitable for food use
- 100% acid resistant
- 100% non fading

**BLANCO turns a sink into a sink centre.
Tips for making the right choice.**



Optimum space utilisation for more comfort.
BLANCO offers solutions for any size of sink cabinet. A cabinet width of 60 cm is ideal for sinks with a main and additional bowl



Ergonomics and functionality.
The main and additional bowls and accessories are designed to match each other perfectly. Comfort solutions – such as the Axial concept – help to achieve efficient working.



Cleaning made easy.
The surfaces of sinks and mixer taps are wonderfully easy to clean. Special materials help to repel dirt and water.



Mixer taps by BLANCO
BLANCO offers a wide selection of designs of high functionality. Certified in accordance with the strict quality criteria of independent test institutes, they meet the highest requirements for safety and hygiene.



Material and colour add highlights.
The right combination of sink and mixer tap creates an ambience that matches any home living style.

BLANCO EasyCare – Care is more than a superficial matter.



SILGRANIT™
The material contains water and dirt repellent agents.
Permanently easy to care for.



BLANCO CARE
Care products from BLANCO are specially designed to suit the respective materials. All conceivable problems can be dealt with. From scratches through limescale deposits and fingerprints to rust, metal abrasion and discolouration.



BLANCO WARRANTY
Offers 10 years* warranty on manufacturing defect or faulty workmanship on Blanco products
*T & C apply

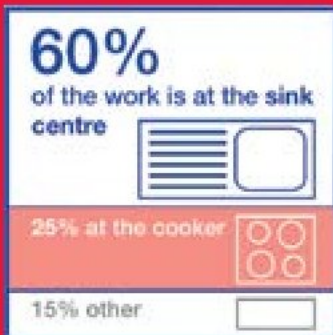

An independent survey proves it: the heart of every kitchen is the sink. Over 60% of the work is done here, despite dishwashers! This creates a great deal of dirt, of course. And this must be cleaned away. But this costs time. This is a great deal to expect but, at BLANCO, it is precisely this which is the driving force behind our developments. We want to make kitchen chores as

simple and as easy as possible. BLANCO EasyCare is the name behind this concept, a superior product concept: Sinks, which are simply easier to clean! Whether they are stainless steel, SILGRANIT™ or ceramic ... BLANCO sinks are the right choice for:

- the degree of work facilitation
- the long term value of the kitchen
- the pleasure from and in the kitchen



design award winner
2003



design award winner
2004



product design award gold
2007



product design award
2008



product design award
2012



product design award
2013



reddot design award winner 2013



NOMINIERT





Unsurpassed ease of cleaning.



Material properties

The stony-silky surface and very finely pored, closed surface create a soft stone-like character that is soft to touch.

BLANCO NAYA 8 S - SILGRANIT™



Tailored to your style

- Balanced, modern lines
- Generously designed main and additional bowl
- Functionally designed drainer with depositing and working area
- Spacious tap ledge with room for a mixer tap and soap dispenser
- For the 80 cm sink cabinet



1 Finish: Anthracite



2 Finish: Alu Metallic



3 Finish: White



4 Finish: Rock Grey



5 Finish: Coffee

80 cm cabinet size

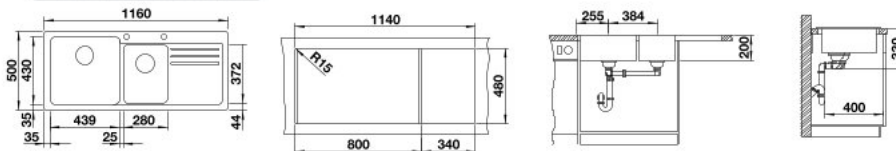

Optional accessories



Outlet Cover CapFlow
565.69.890



Odour Trap
565.69.039

Scope of supply: Waste fitting with drain pipes

ORDERING INFORMATION

Product Description	Over all Size (mm/inch)	Bowl Size (mm/inch)	Half bowl size (mm/inch)	Finish	Article No.
1	1160mmx500mm/ 45.66" x 19.68"	439x430mmx200mm/ 17.28" x16.92" x 7.87"	280x372mmx200mm/ 11.02" x 14.65" x 7.87"	Anthracite	565.71.350
2	1160mmx500mm/ 45.66" x 19.68"	439x430mmx200mm/ 17.28" x16.92" x 7.87"	280x372mmx200mm/ 11.02" x 14.65" x 7.87"	Alu Metallic	565.71.950
3	1160mmx500mm/ 45.66" x 19.68"	439x430mmx200mm/ 17.28" x16.92" x 7.87"	280x372mmx200mm/ 11.02" x 14.65" x 7.87"	White	565.71.750
4	1160mmx500mm/ 45.66" x 19.68"	439x430mmx200mm/ 17.28" x16.92" x 7.87"	280x372mmx200mm/ 11.02" x 14.65" x 7.87"	Rock Grey	565.71.550
5	1160mmx500mm/ 45.66" x 19.68"	439x430mmx200mm/ 17.28" x16.92" x 7.87"	280x372mmx200mm/ 11.02" x 14.65" x 7.87"	Coffee	565.71.850

BLANCO SONA 8 S - SILGRANIT™

Tailored to contemporary kitchens

- Modern, independent design
- Two bowls of the same size for maximum comfort when washing dishes
- Harmoniously integrated, lower additional outlet made of SILGRANIT™
- Generous, strikingly-profiled tap ledge
- Specially for the 80-cm base cabinet

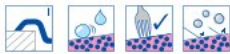

1 Finish: Anthracite



2 Finish: Alu Metallic



3 Finish: White



5 Finish: Rock Grey



6 Finish: Coffee

80 cm cabinet size

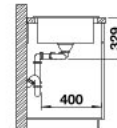
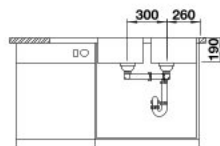
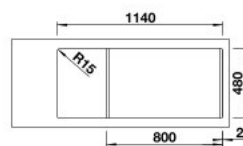
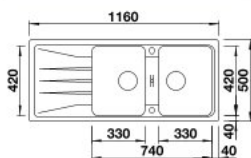

Optional accessories



Outlet Cover CapFlow
565.69.890



Odour Trap
565.69.039

Scope of supply: Waste fitting with drain pipes

ORDERING INFORMATION

Product Description	Over all Size (mm/inch)	Each Bowl Size (mm/inch)	Bowl Depth	Finish	Article No.
1	1160x500 / 45.66" x 19.68"	330x420 / 13"x16.53"	190mm / 7.48"	Anthracite	567.70.300
2	1160x500 / 45.66" x 19.68"	330x420 / 13"x16.53"	190mm / 7.48"	Alu Metallic	567.70.900
3 BLANCO SONA 8 S	1160x500 / 45.66" x 19.68"	330x420 / 13"x16.53"	190mm / 7.48"	White	567.70.700
4	1160x500 / 45.66" x 19.68"	330x420 / 13"x16.53"	190mm / 7.48"	Rock Grey	567.70.500
5	1160x500 / 45.66" x 19.68"	330x420 / 13"x16.53"	190mm / 7.48"	Coffee	567.70.800

BLANCO SONA 6 S - SILGRANIT™



Tailored to contemporary kitchens

- Modern, independent design
- Kitchen tasks are made much easier by the roomy main bowl and practical additional bowl
- Generous, strikingly-profiled tap ledge
- Specially for the 60-cm base cabinet

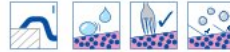

1 Finish: Anthracite



2 Finish: Alu Metallic



3 Finish: Rock Grey



4 Finish: Coffee

60 cm cabinet size

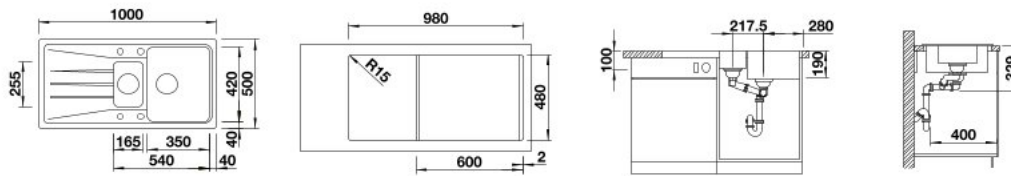

Optional accessories



Outlet Cover CapFlow
565.69.890



Odour Trap
565.69.039

Scope of supply: Waste fitting with drain pipes

ORDERING INFORMATION

Product Description	Over all Size (mm/inch)	Bowl Size (mm/inch)	Half bowl size (mm/inch)	Finish	Article No.
BLANCO SONA 6 S	1000x500 / 39.37" x19.68"	350x420x190 / 13.77"x16.53"x7.48"	165x255x100 / 6.49"x10.04"x3.93"	Anthracite	567.70.310
	1000x500 / 39.37" x19.68"	350x420x190 / 13.77"x16.53"x7.48"	280x372x200 / 11.02" x 14.65" x 7.87"	Alu Metallic	567.70.910
	1000x500 / 39.37" x19.68"	350x420x190 / 13.77"x16.53"x7.48"	280x372x200 / 11.02" x 14.65" x 7.87"	Rock Grey	567.70.510
	1000x500 / 39.37" x19.68"	350x420x190 / 13.77"x16.53"x7.48"	280x372x200 / 11.02" x 14.65" x 7.87"	Coffee	567.70.810

BLANCOMETRA XL 6 S SILGRANIT

Clear outline with a hint of luxury and increased capacity

- Young, straight-lined design
- The unsurpassed capacity of the bowl provides even more room to do the washing up
- Aesthetic low-profile rim design
- Can be installed either way round and also as undermount sink
- Cutting boards in various designs and crockery basket available as optional extras



1 Finish: Anthracite

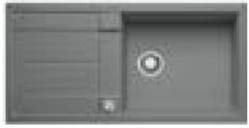

2 Finish: Alu metallic



3 Finish: White



4 Finish: Rock Grey



5 Finish: Coffee



6 Finish: Tartufo

Optional accessories



Outlet Cover CapFlow
565.69.890



Odour Trap
565.69.039

60 cm cabinet size

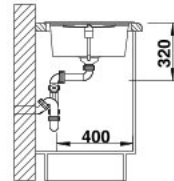
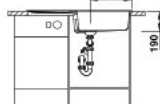
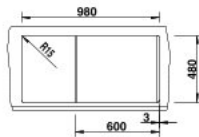
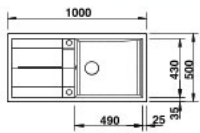

Bowl depth: 190mm
○ = Pre-drilled holes for knock-out at site

ORDERING INFORMATION

Product Description	Over all Size (mm/inch)	Bowl Size (mm/inch)	Half Bowl Size (mm/inch)	Finish	Article No.
BLANCOMETRA XL 6 S	1000x500x190 & 130/ 39.37"x19.68"x7.48" & 5.12"	490x430 / 19.29" x 16.92"	285x170x130 / 11.22" x 6.69" x 5.12"	Anthracite	565.76.390
	1000x500x190 & 130/ 39.37"x19.68"x7.48" & 5.12"	490x430 / 19.29" x 16.92"	285x170x130 / 11.22" x 6.69" x 5.12"	Alu metallic	565.76.990
	1000x500x190 & 130/ 39.37"x19.68"x7.48" & 5.12"	490x430 / 19.29" x 16.92"	285x170x130 / 11.22" x 6.69" x 5.12"	White	565.76.790
	1000x500x190 & 130/ 39.37"x19.68"x7.48" & 5.12"	490x430 / 19.29" x 16.92"	285x170x130 / 11.22" x 6.69" x 5.12"	Rock Grey	567.67.590
	1000x500x190 & 130/ 39.37"x19.68"x7.48" & 5.12"	490x430 / 19.29" x 16.92"	285x170x130 / 11.22" x 6.69" x 5.12"	Coffee	565.76.890
	1000x500x190 & 130/ 39.37"x19.68"x7.48" & 5.12"	490x430 / 19.29" x 16.92"	285x170x130 / 11.22" x 6.69" x 5.12"	Tartufo	565.76.090

BLANCOMETRA 8 S SILGRANIT



Clean lines maximum comfort

- Young, straight-lined design
- Particularly spacious bowls provide an unsurpassed amount of room
- The additional bowl provides a high degree of comfort
- Aesthetic low-profile rim design
- Available in all SILGRANIT™ colours
- Can be installed either way round and also as undermount sink



1 Finish: Anthracite



2 Finish: Alu metallic



3 Finish: White



4 Finish: Rock Grey



5 Finish: Coffee

80 cm cabinet size

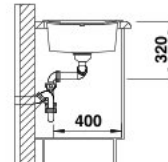
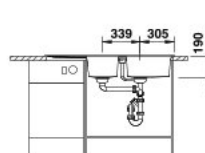
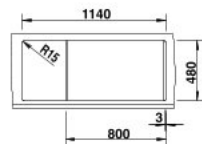
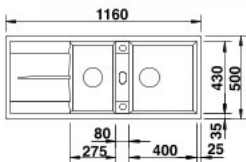

Bowl depth: 190/130mm
 ○= Pre-drilled holes for knock-out at site

Optional accessories



Outlet Cover CapFlow
565.69.890



Odour Trap
565.69.039

ORDERING INFORMATION

Product Description	Over all Size (mm/inch)	Bowl Size (mm/inch)	Half Bowl Size (mm/inch)	Depth (mm/inch)	Finish	Article No.
1	1160x500x190 & 190 / 39.37" x 19.68"x7.48" & 7.48"	430x400 mm / 16.92" x 15.74"	430x275 mm / 16.92" x 10.82"	190 mm / 7.48"	Anthracite	565.70.340
2	1160x500x190 & 190 / 39.37" x 19.68"x7.48" & 7.48"	495x340 mm / 19.48" x 13.38"	430x275 mm / 16.92" x 10.82"	190 mm / 7.48"	Alu Met- allic	565.70.940
3	1160x500x190 & 190 / 39.37" x 19.68"x7.48" & 7.48"	495x340 mm / 19.48" x 13.38"	430x275 mm / 16.92" x 10.82"	190 mm / 7.48"	White	565.70.740
4	1160x500 mm / 45.66"x19.68"	495x340 mm / 19.48" x 13.38"	430x275 mm / 16.92" x 10.82"	190 mm / 7.48"	Rock Grey	565.70.540
5	1160x500 mm / 45.66"x19.68"	495x340 mm / 19.48" x 13.38"	430x275 mm / 16.92" x 10.82"	190 mm / 7.48"	Coffee	565.70.440

BLANCOMETRA 9 SILGRANIT

Clean lines maximum comfort

- Young, straight-lined design
- Particularly spacious bowls provide an unsurpassed amount of room
- Large tap ledge for installation of mixer tap and soap dispenser
- Aesthetic low-profile rim design



1 Finish: Anthracite



2 Finish: Alu Metallic



3 Finish: White



4 Finish: Rock Grey



5 Finish: Coffee

90 cm cabinet size

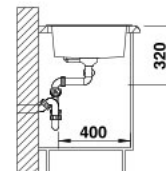
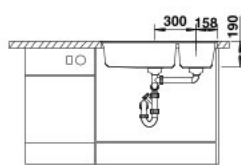
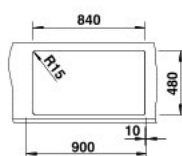
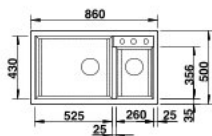

Bowl depth: 190/190mm
 ○ = Pre-drilled holes for knock-out at site

Optional accessories



Outlet Cover CapFlow
565.69.890



Odour Trap
565.69.039



Plug for Tap Hole
565.69.909

Scope of supply: Waste fitting with drain pipes

ORDERING INFORMATION

Product Description	Over all Size (mm/inch)	Bowl Size (mm/inch)	Half Bowl Size (mm/inch)	Depth (mm/inch)	Finish	Article No.
1	860x500 mm / 33.85"x19.68"	495x340 mm / 20.66"x16.92"	356x260 mm / 14.01"x10.23"	190 mm / 7.48"	Anthracite	565.70.352
2	860x500 mm / 33.85"x19.68"	495x340 mm / 20.66"x16.92"	356x260 mm / 14.01"x10.23"	190 mm / 7.48"	Alu Metallic	565.70.952
3	860x500 mm / 33.85"x19.68"	495x340 mm / 20.66"x16.92"	356x260 mm / 14.01"x10.23"	190 mm / 7.48"	White	565.70.752
4	860x500 mm / 33.85"x19.68"	495x340 mm / 20.66"x16.92"	356x260 mm / 14.01"x10.23"	190 mm / 7.48"	Rock Grey	565.70.552
5	860x500 mm / 33.85"x19.68"	495x340 mm / 20.66"x16.92"	356x260 mm / 14.01"x10.23"	190 mm / 7.48"	Coffee	565.70.452

BLANCONAYA 6 SILGRANIT™



Tailored to your style

- Balanced, modern lines
- Spacious, deep single bowl with integrated overflow and continuous tap ledge
- Sink comfort in a compact shape
- For the 60 cm base cabinet



1 Finish: Anthracite



2 Finish: Alu Metalic



3 Finish: White



4 Finish: Rock Grey



5 Finish: Coffee



6 Finish: Tartufo

60 cm cabinet size

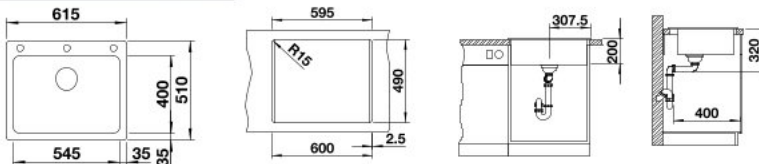

Optional accessories



Outlet Cover CapFlow
565.69.890



Odour Trap
565.69.039

Scope of supply: Waste fitting with drain pipes

ORDERING INFORMATION

Product Description	Over all Size (mm/inch)	Bowl Size (mm/inch)	Depth (mm/inch)	Finish	Article No.
1	615x510 / 24.21" x 20.07"	545x400/ 21.45" x 15.74"	200 / 7.87"	Anthracite	565.71.330
2	615x510 / 24.21" x 20.07"	545x400/ 21.45" x 15.74"	200 / 7.87"	Alu Metalic	565.71.930
3	615x510 / 24.21" x 20.07"	545x400/ 21.45" x 15.74"	200 / 7.87"	White	565.71.730
4	615x510 / 24.21" x 20.07"	545x400/ 21.45" x 15.74"	200 / 7.87"	Rock Grey	565.71.530
5	615x510 / 24.21" x 20.07"	545x400/ 21.45" x 15.74"	200 / 7.87"	Coffee	565.71.830
6	615x510 / 24.21" x 20.07"	545x400/ 21.45" x 15.74"	200 / 7.87"	Tartufo	565.71.030

BLANCOPLEON 8 SILGRANIT

Pure elegance - rich volume

- Timelessly elegant, straight-lined design
- Single bowl with maximum volume thanks to particularly deep bowl
- Continuous, generous tap ledge
- Easy to clean, flowing transition from the sink's rim to the tap ledge
- Elegant and hygienic: the concealed overflow C-overflow™
- With 3 1/2" basket strainers



1 Finish: Anthracite 2 Finish: Alu metallic 3 Finish: White



4 Finish: Rock Grey 5 Finish: Coffee 6 Finish: Tartufo

80 cm cabinet size

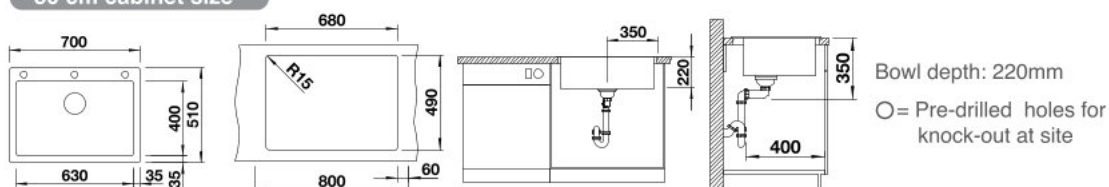

Optional accessories



Outlet Cover CapFlow
565.69.890



Odour Trap
565.69.039



Plug for Tap Hole
565.69.909

Scope of supply: Waste fitting with drain pipes

ORDERING INFORMATION

Product Description	Over all Size (mm/inch)	Bowl Size (mm/inch)	Depth (mm/inch)	Finish	Article No.
1	700x510/ 27.55" x 20.07"	630x400/ 24.80" x 15.74"	220 / 8.66"	Anthracite	567.68.300
2	700x510/ 27.55" x 20.07"	630x400/ 24.80" x 15.74"	220 / 8.66"	Alu Metallic	567.68.900
3	700x510/ 27.55" x 20.07"	630x400/ 24.80" x 15.74"	220 / 8.66"	White	567.68.700
4	700x510/ 27.55" x 20.07"	630x400/ 24.80" x 15.74"	220 / 8.66"	Rock Grey	570.25.530
5	700x510/ 27.55" x 20.07"	630x400/ 24.80" x 15.74"	220 / 8.66"	Coffee	570.25.830
6	700x510/ 27.55" x 20.07"	630x400/ 24.80" x 15.74"	220 / 8.66"	Tartufo	570.25.030

BLANCOPLEON 9 SILGRANIT



Pure elegance - rich volume

- Timelessly elegant, straight-lined design
- Main bowl and additional bowl with maximum volume thanks to particularly deep bowls
- Spacious tap ledge
- Easy to clean, flowing transition from the sink's rim to the tap ledge
- Elegant and hygienic: the concealed overflow C-overflow™
- With 3 1/2" basket strainers



1 Finish: Anthracite



2 Finish: Alu Metallic



3 Finish: White



4 Finish: Rock Grey



5 Finish: Coffee



6 Finish: Tartufo

90 cm cabinet size

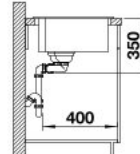
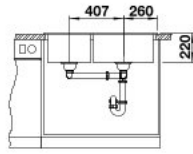
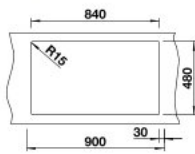
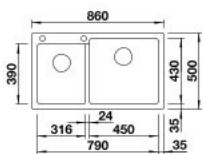

Bowl depth: 220mm
 ○ = Pre-drilled holes for knock-out at site

Optional accessories



Outlet Cover CapFlow
565.69.890



Plug for Tap Hole
565.69.909



Odour Trap
565.69.039

ORDERING INFORMATION

Product Description	Over all Size (mm/inch)	Bowl Size (mm/inch)	Half Bowl Size (mm/inch)	Depth (mm/inch)	Finish	Article No.
1	860x500 / 33.85"x19.68"	450x430/17.71"x16.92"	316x390 / 12.44"x15.35"	220/ 8.66"	Anthracite	567.68.320
2	860x500 / 33.85"x19.68"	450x430 / 17.71"x16.92"	316x390/ 12.44"x15.35"	220/ 8.66"	Alu Metallic	567.68.920
3	860x500 / 33.85"x19.68"	450x430 / 17.71"x16.92"	316x390 / 12.44"x15.35"	220/ 8.66"	White	567.68.720
4	860x500 / 33.85"x19.68"	450x430 / 17.71"x16.92"	316x390 / 12.44"x15.35"	220/ 8.66"	Rock Grey	570.25.540
5	860x500 / 33.85"x19.68"	450x430 / 17.71"x16.92"	316x390 / 12.44"x15.35"	220/ 8.66"	Coffee	570.25.840
6	860x500 / 33.85"x19.68"	450x430 / 17.71"x16.92"	316x390 / 12.44"x15.35"	220/ 8.66"	Tartufo	570.25.040

BLANCORONDO SILGRANIT

The sink for individualists

- Ideal solution for small kitchens
- Large bowl
- **Optional accessory:** crockery basket



1 Finish: Anthracite



2 Finish: Alu Metallic



3 Finish: White



4 Finish: Coffee

45 cm cabinet size

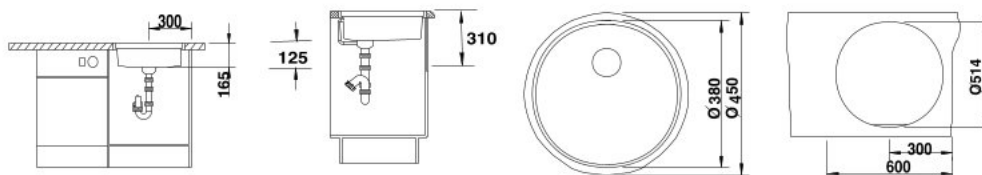

Bowl depth: 165mm
 ○ = Pre-drilled holes for knock-out at site

Optional accessories



Outlet Cover CapFlow
565.69.890



Odour Trap
565.69.039

Scope of supply: Waste fitting with drain pipes

ORDERING INFORMATION

Product Description	Ø Diameter(mm/inch)	Depth(mm/inch)	Finish	Article No.
1 2 3 4 BLANCORONDO	450 / 17.71"	165 / 6.49"	Anthracite	565.70.390
	450 / 17.71"	165 / 6.49"	Alu Metallic	565.70.990
	450 / 17.71"	165 / 6.49"	White	565.70.790
	450 / 17.71"	165 / 6.49"	Coffee	565.70.490

BLANCO NAYA XL 9 SILGRANIT



TAILORED TO YOUR STYLE

- 100% suitable for food use
- 100% acid resistant
- 100% non-fading



1 Finish: Anthracite



2 Finish: Alu metallic



3 Finish: White



4 Finish: Rock Grey



5 Finish: Coffee

90 cm cabinet size



Bowl depth: 220mm
 O = Pre-drilled holes for knock-out at site

Optional accessories



Outlet Cover CapFlow
565.69.890



Plug for Tap Hole
565.69.909



Odour Trap
565.69.039

ORDERING INFORMATION

Product Description	Over all Size (mm/inch)	Bowl Size (mm/inch)	Depth (mm/inch)	Finish	Article No.
1	860x510 / 33.86"x20.08"	790x400/ 31.10"x15.75"	220/ 8.66"	Anthracite	570.25.320
2		790x400/ 31.10"x15.75"	220/ 8.66"	Alu Metallic	570.25.920
3		790x400/ 31.10"x15.75"	220/ 8.66"	White	570.25.720
4		790x400/ 31.10"x15.75"	220/ 8.66"	Rock Grey	570.25.520
5		790x400/ 31.10"x15.75"	220/ 8.66"	Coffee	570.25.820



Aesthetics and function
in all their facets.

Mixer taps from BLANCO.

Equip your sink centre with a tap which matches the design of your kitchen. BLANCO mixer taps incorporate a high quality mechanism, are equipped with a wide variety of additional functions and make all your chores much easier – from washing salad to cleaning pans. Make the most of the high degree of creative freedom they offer and combine the materials and colours of the SILGRANIT™-look or ceramic-look taps with the matching sinks.

Put your trust in BLANCO mixer taps.

Quality for the sake of your health.



Avoid risks to your health.

Untested taps can significantly exceed the maximum permissible value for substances which endanger health. BLANCO taps are extensively tested and certified. They thus provide maximum safety in terms of health and hygiene.

Clean water is our contribution to your health.

BLANCO proves its high sense of responsibility towards people and the environment in many ways, not only by exclusively using certified quality materials in all water-conducting parts of BLANCO taps, but also by continuously monitoring them by means of voluntary tests.

The advantages for you:

- a good feeling every day about the hygiene and health protection for the whole family
- confirmed safety when buying taps
- durable products with high quality

BLANCO taps: seal of approval for safety and hygiene.

Blanco has the technology and hygiene of its taps voluntarily tested according to the stipulations of the German drinking water regulation and certified by the DVGW Cert GmbH (Certification body of the German Scientific and Technical Association for Gas and Water e.V.).

With this certification BLANCO taps provide one of the highest qualities currently available on the German market.

The voluntary certification by the DVGW is BLANCO's documentary proof that the requirements for the protection of drinking water are being observed.

Before the certification takes place, the technology and hygiene of a range of taps are subjected to a large number of individual tests by various, independent institutes.

The following criteria are an essential part of these tests:

- safeness of the materials used (all materials coming into contact with water are tested for hygienic properties and constituents which can present a health hazard)
- durability in hot-cold permanent use
- flow rate
- intensity of water noise



The patented Neoperl cascade reduces limescale and provides an even flow of water.



The integrated check valve keeps used water away when the spray is in use.



Elastic silicone nubs keep the spray free of limescale, and are easily cleaned just by rubbing with a finger.



Because they are so long, the flexible connection hoses are ideal even for difficult conditions.



Long-life ceramic disc cartridges provide for a precise adjustment of water amount and temperature.

BLANCO CARENA-S Vario

Features

Bold design with a special functionality

- Classic modern premium mixer tap
- Covered pull-out two-spray hose with changeover function at the back
- High arched outlet for easy filling of pots and vases
- High positioned, ergonomic control lever
- Bi-colour (Dual finish comprising of metallic surface and SILGRANIT™ look)
- Material: Brass

Technical Specification

- Water flow rate: 7.3 litres/ min at 3 bar pressure (mixed flow)
- 190° swivel spout for greater reach
- 35 mm tap hole required
- With ceramic disk cartridge
- Textile covered spray hose
- Flexible connector pipes, 450 mm long and 3/8" nut for particularly easy installation
- Patented jet regulator for markedly reduced scaling
- Stabilisation plate to increase the stability of the tap when fitted in stainless steel sinks
- LGA approved



Dual Spray Function

Pull-out Hose Feature



1 Chrome 2 Anthracite 3 Rock Grey 4 Alu Metallic



5 Coffee 6 Tartufo 7 White

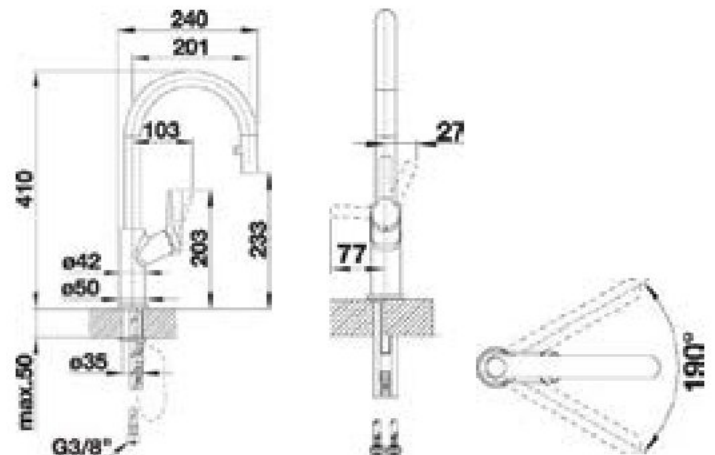

ORDERING INFORMATION

Product Description	Finish	Article No.
1	Chrome	569.03.260
2	Anthracite	569.03.360
3	Rock Grey	569.03.566
4	Alu Metallic	569.03.960
5	Coffee	569.03.860
6	Tartufo	569.03.060
7	White	569.03.760

BLANCO MILI



Features

Comfort with contours

- Slender body with a J-shaped spout
- High arched outlet for the easy filling of tall pots and vases
- Enlarged working radius thanks to the 360° swivel spout
- Colours of the faucet match the look and texture of the SILGRANIT™ sinks and bowls
- Material: Brass

Technical Specification

- **Water flow rate:** 13.44 litres/ min at 3 bar pressure (mixed flow)
- Single-lever mixer tap
- 35 mm tap hole required
- With ceramic disk cartridge
- Flexible connector pipes, 350 mm long and 3/8" nut for particularly easy installation

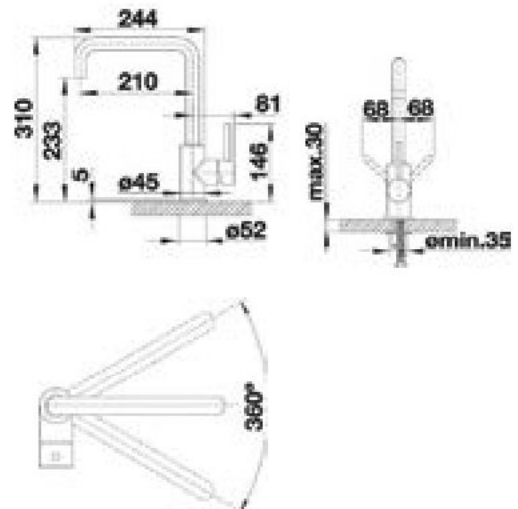

ORDERING INFORMATION

Product Description	Finish	Article No.
[1] BLANCO MILI	Chrome	569.09.260
	Anthracite	569.09.360
	Alu Metallic	569.09.960
	Coffee	569.09.870
	White	569.09.760

BLANCO TIVO-S

Features

Comfort combined with aesthetics

- High spout for easier work at the sink
- Extendable spray with switching function
- Particularly adapted for modern sinks
- Bi-colour (Dual finish comprising of metallic surface and SILGRANIT™ look)
- Material: Brass

Technical Specification

- **Water flow rate:** 9.23 litres/ min at 3 bar pressure (mixed flow)
- Spout can be swivelled by 120°
- 35 mm tap hole required
- With ceramic disk cartridge
- Metal-sheathed spray hose
- Flexible connection pipes with a length of 450 mm and 3/8" nut for particularly easy and secure installation
- Patented jet regulator for markedly reduced scaling
- Stabilisation plate to increase the stability of the tap when fitted in stainless steel sinks
- LGA approved
- DVGW approved

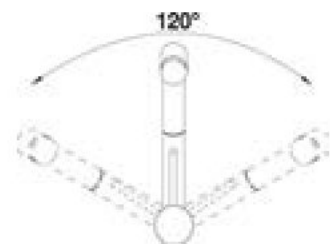
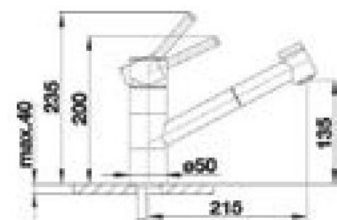

ORDERING INFORMATION

Product Description		Finish	Article No.
1	BLANCO TIVO-S	Chrome	569.02.210
2		Anthracite	569.02.310
3		Rock Grey	569.02.516
4		Alu Metallic	569.02.910
5		Coffee	569.02.810
6		Tartufo	569.02.010
7		White	569.02.710

BLANCO MIDA-S



Features

Stylish slender form

- Gently rounded spout on a slim body
- High arched outlet for the easy filling of tall pots and vases
- Especially suitable for compact sinks
- Enlarged working radius thanks to the 360° swivel spout
- Pull-down spray hose for added reach
- Colours of the faucet match the look and texture of the SILGRANIT™ sinks and bowls
- Material: Brass

Technical Specification

- **Water flow rate:** 11.07 litres/ min at 3 bar pressure (mixed flow)
- 35 mm tap hole required
- With ceramic disk cartridge
- Flexible connector pipes, 350 mm long and 3/8" nut for particularly easy installation
- Nylon-sheathed spray hose
- Patented jet regulator for markedly reduced scaling
- Stabilisation plate to increase the stability of the tap when fitted in stainless steel sinks
- LGA approved



1 Chrome 2 Anthracite 3 Alu Metallic



4 Coffee 5 White

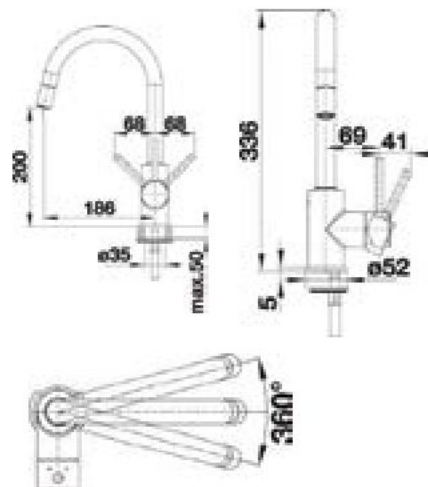

ORDERING INFORMATION

Product Description		Finish	Article No.
1	BLANCO MIDA-S	Chrome	569.10.200
2		Anthracite	569.10.300
3		Alu Metallic	569.10.900
4		Coffee	569.10.800
5		White	569.10.700

BLANCO LINUS-S - SILGRANIT™ -Look

Features

Practical in form and function

- High arc spout for easy filling of pans and vases
- High-quality metal design of the spray (pull out)
- Lever can be positioned on the left, the right or in the centre
- Design and colour of tap and coloured sink are a perfect match (SILGRANIT-look)
- Extendable spray (pull out)
- Water flow rate of 6L/minute at 3 bar dynamic water pressure

Technical Specification

- Swivel spout
- 35 mm Ø tap hole required
- With ceramic seals
- Metal-sheathed spray hose
- Flexible 450 mm connector hoses and 3/8" nut for particularly easy and secure installation
- Patented jet regulator /cascade for markedly reduced scaling
- Stabilising plate to increase the stability of the tap when fitted in stainless steel sinks
- Equipped with non-return valve as standard and hence intrinsically safe against back flow in accordance with EN 1717
- LGA approved
- DVGW approved

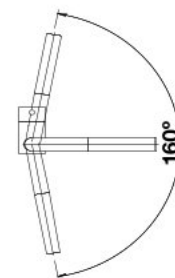
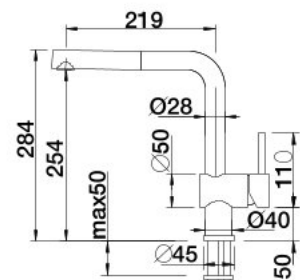

ORDERING INFORMATION

Product Description	Finish	Article No.
1 2 3 4 5 6 7 BLANCO LINUS-S	Chrome	565.68.250
	Anthracite	565.68.350
	Rock Grey	565.68.550
	Alu Metallic	565.68.950
	Coffee	565.68.450
	Tartufo	565.68.050
	White	565.68.750

BLANCO MILA-S



Classic and clear

- Slender body with a straight-lined spout
- With extendable spray (pull out)
- For the easy filling of tall pots and vases
- Enlarged working radius thanks to the 360° swivel spout
- Single-lever mixer tap
- Spout can be swivelled by 360°
- Ø 35 mm tap hole required
- With ceramic disk cartridge
- Nylon-sheathed spray hose
- Flexible connector pipes, 350 mm long and 3/8" nut for particularly easy installation

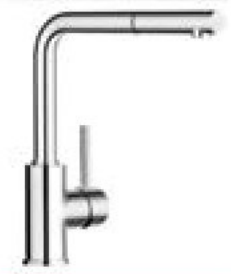

1 Finish: Chrome

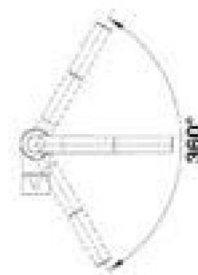
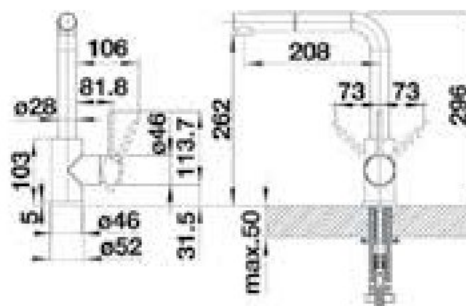

ORDERING INFORMATION

Product Description	Finish	Article No.
1 BLANCOMILA-S	Chrome	569.06.210

BLANCOMIDA

- Single-lever mixer tap
- Spout can be swivelled by 360°
- Ø35 mm tap hole required
- With ceramic disk cartridge
- Flexible connector pipes, 350 mm long and 3/8" nut for particularly easy installation
- LGA approved
- High spout for easy filling of pans and vases
- Enlarged radius: spout revolvable 360°



1 Finish: Chrome

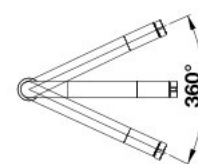
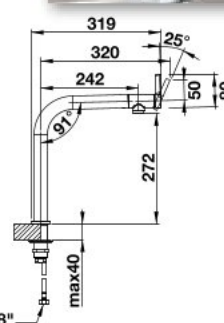
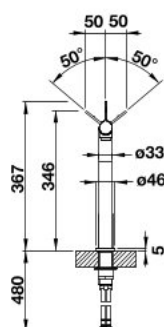

ORDERING INFORMATION

Product Description	Finish	Article No.
1 BLANCOMIDA	Chrome	569.04.230

BLANCODARAS-S

Metallic surface and SILGRANIT™-Look

With extendable spray head

- Particularly suitable for small sinks
- Available in chrome



1 Finish: Chrome



Dimensions chrome version

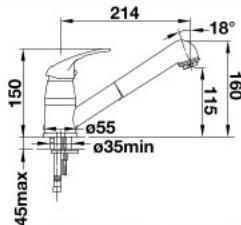

Dimensions chrome version

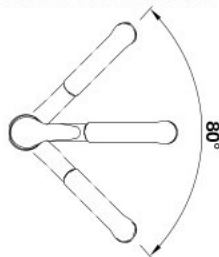

Dimensions SILGRANIT™-Look version

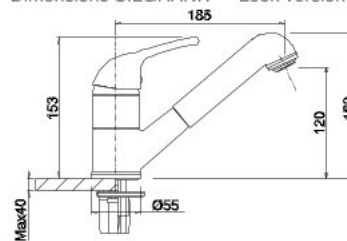

Dimensions SILGRANIT™-Look version

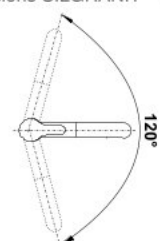

ORDERING INFORMATION

Product Description	Finish	Article No.
1 BLANCODARAS S	Chrome	569.06.260

BLANCODARAS

Metallic surface and SILGRANIT™-Look



- Particularly suitable for small sinks
- Enlarged working radius due to 360° swivelling spout
- Available in chrome finish



1 Finish: Chrome

Dimensions chrome version

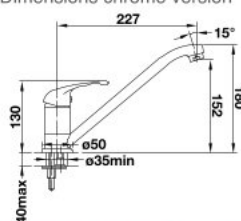

Dimensions chrome version

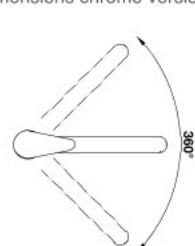

Dimensions SILGRANIT™-Look version

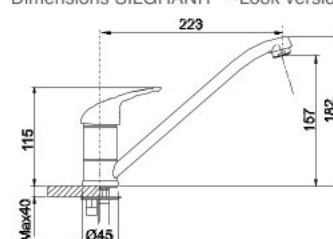

Dimensions SILGRANIT™-Look version

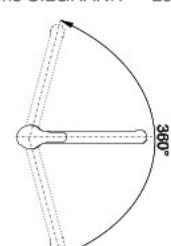

ORDERING INFORMATION

Product Description	Finish	Article No.
1 BLANCODARAS	Chrome	569.05.250



think green

Smart Lime Cleaning:

The Italian Kitchen Taps by Häfele have an Anti-Lime pure water outlet design for their aerator which reduces the possibility of lime formation & increases the maximum lifespan of your faucet aerator

Water Sense Technology:

These taps are integrated with a Water sense Technology which saves 20% more water than similar products in the market.

Vandal Resistant Aerator:

The Italian Kitchen Taps by Häfele have vandal resistant aerators which can not be removed without using special key, which is supplied with the products

How to save water?

Consumptions can be reduced and it's easier than what you think

> Avoid wasting.

For example, use full load washing machine and dishwasher, water the plants at evening when temperature is lower, do not leave taps open unless necessary (letting the water run as you brush your teeth)...

> Use low water consumption systems.

Flow reducers, thermostatic taps, aerated taps and low consumption appliances together with a water use attentive and rational, guarantee remarkable drinking water saving up to 20-30%.

FLAMBE ROUND

- Suspended spray with stainless steel spring
- Soft touch spray surface
- Rotating spout 360°
- Cartridge with ceramic discs
- Hole diameter 35 mm
- Height of mixer 609 mm
- Height up to aerator 277 mm
- Vandal resistant aerator
- Water sense technology
- Flow rate 7,8 L / min at 3 bar flow pressure

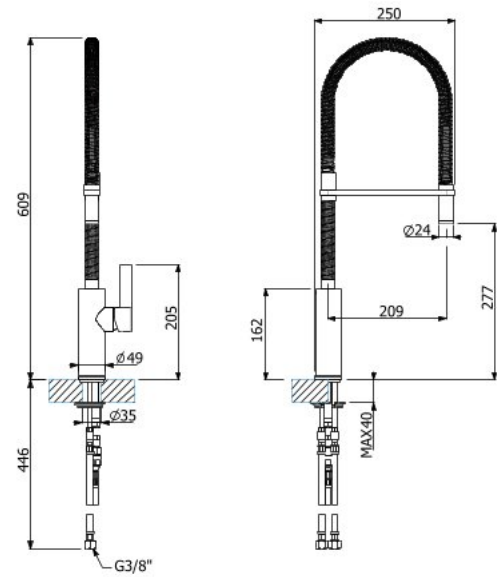

ORDERING INFORMATION

Product Description	Chrome	Brushed Chrome
1 FLAMBE ROUND - Single lever kitchen mixer with turning spout shower	566.22.210	566.24.280

SOLO



- Rotating spout 360°
- Cartridge with ceramic discs
- Hole diameter 35 mm
- Height of mixer 332 mm
- Height up to aerator 315 mm
- Smart lime cleaning aerator
- Water sense technology
- Flow rate 9,4 L / min at 3 bar flow pressure

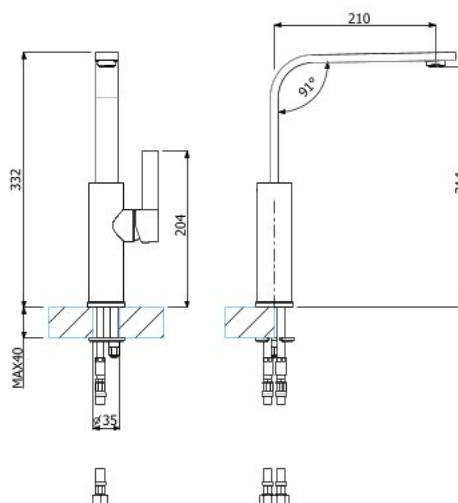

ORDERING INFORMATION

Product Description	Chrome	Brushed Chrome
1 SOLO	566.23.270	566.24.240

CENTURY

- Soft tough handle surface
- Rotating spout 360°
- Cartridge with ceramic discs
- Hole diameter 35 mm
- Height of mixer 307 mm
- Height up to aerator 168 mm
- Vandal resistant aerator with rectangular shape
- Water sense technology
- Flow rate 8 L / min at 3 bar flow pressure

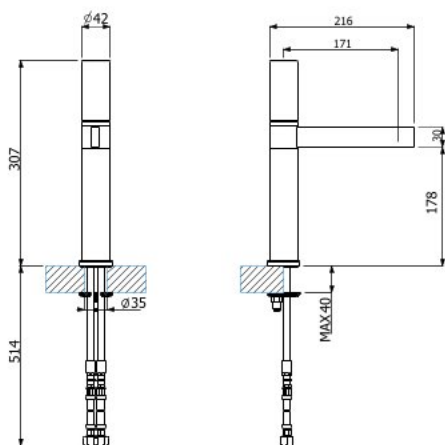

ORDERING INFORMATION

Product Description	Chrome	Brushed Chrome
1 CENTURY	566.22.230	566.24.290

BE PURE

- Dual-flow vicario system for drinking water.
- Copper pipe for healthy and clean
- Rotating spout 360°
- Cartridge with ceramic discs
- Ceramic valve for pure water
- Hole diameter 35 mm
- Height of mixer 312 mm
- Height up to aerator 280 mm
- Smart lime cleaning aerator
- Anti-liming pure water outlet design
- Water sense technology
- Flow rate 9,8 L / min at 3 bar flow pressure



ORDERING INFORMATION

Product Description	Chrome	Brushed Chrome	Anthracite	Alumetallic	Rock Grey	Coffee
1 BE PURE - Single lever kitchen mixer with separate outlet for drinking water	566.22.290	566.24.220	566.28.340	566.28.940	566.28.540	566.28.840

SLIM



- Extendable spray (dual flow jet)
- 1500 mm shower hose for extendable spray
- Rotating spout 360°
- Cartridge with ceramic discs
- Hole diameter 35 mm
- Height of mixer 479 mm
- Height up to aerator 271 mm
- Vandal resistant aerator
- Water sense technology
- Low rate 6,6 L / min at 3 bar flow pressure

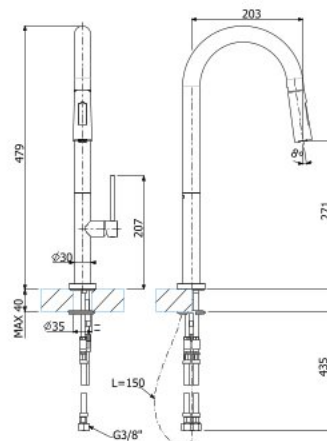

ORDERING INFORMATION

Product Description	Chrome	Brushed Chrome	Anthracite	Alumetallic	Rock Grey	Coffee
1 SLIM	566.23.280	566.24.250	-	-	-	-

SWING



- Rotating spout 360°
- Cartridge with ceramic discs
- Hole diameter 35 mm
- Height of mixer 335 mm
- Height up to aerator 245 mm
- Smart lime cleaning aerator
- Water sense technology
- Flow rate 9,7 L / min at 3 bar flow pressure

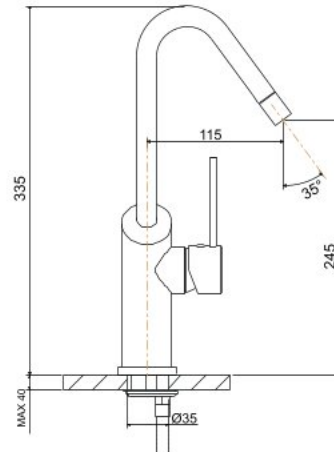

ORDERING INFORMATION

Product Description	Chrome	Brushed Chrome
1 SWING	566.23.290	566.24.260

TROPIC



- Joystick movement cartridge
- Rotating spout 360°
- Cartridge with ceramic discs
- Hole diameter 35 mm
- Height of mixer 376 mm
- Height up to aerator 269 mm
- Smart lime cleaning aerator
- Water sense technology
- Flow rate 9,9 L / min at 3 bar flow pressure

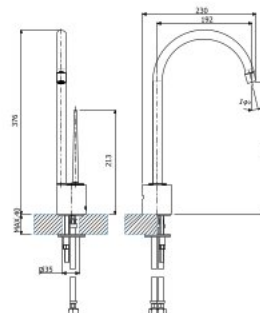

ORDERING INFORMATION

Product Description	Chrome	Brushed Chrome
1 TROPIC	566.22.250	

TRENTA

- Extendable spray
- 1500 mm shower hose for extendable spray
- Rotating spout 360°
- Cartridge with ceramic discs
- Hole diameter 35 mm
- Height of mixer 267 mm
- Height up to aerator 230 mm
- Vandal resistant aerator
- Water sense technology
- Flow rate 11,7 L / min at 3 bar flow pressure

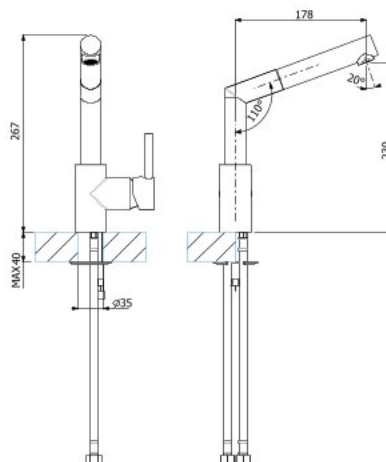

ORDERING INFORMATION

Product Description	Chrome	Brushed Chrome
1 TRENTA	566.21.200	566.21.240

PLUMA
Deck Mounted Cold Faucet



- **Material:** Stainless Steel 304
- **Finish:** Stainless steel brushed
- **Dimensions:** 239 (H) × 152 (D) × 18 (Ø) mm
- **Flow rate:** 7 litres/ min at 3 bar pressure

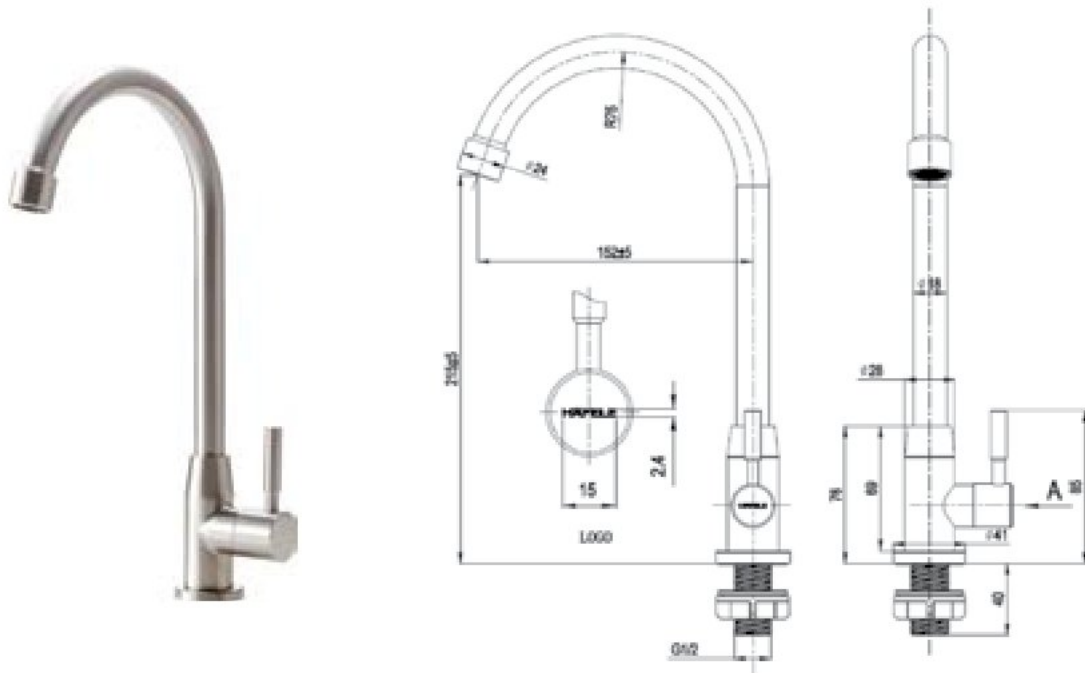

ORDERING INFORMATION

Product Description		Stainless Steel Brushed
1	PLUMA	570.85.031

ARGENTO

Handmade Kitchen Sinks

Machines are known for their precision and speed, but the human touch brings an aspect of quality, sophistication and attentiveness to any task. It is this extra consideration that comes through in Häfele's Range of Handmade Argento Kitchen Sinks. Every sink from this range is a product of meticulous guidance, crafted through the process of manual welding. They come in various sizes and configurations to meet individual requirements and design preferences of every user.

All Argento sinks are made of Stainless Steel Grade 304 which by virtue grants them extraordinary durability and unbeatable performance, and lowers the chances of corrosion and rusting. This along with the Asphalt coating

of the sink base adds an extra layer of protection and prevents any condensation and corrosion. The inherent aseptic property of Stainless Steel makes the surface of the sinks hygienic and easy to clean after the many varied chores of the day.

These sinks come with extra deep bowls to accommodate even large vessels comfortably.

Accomplishing tasks at the sink is also quieter, thanks to the sound suppression pads that absorb noise caused by utensils during the process of washing them. With an elegant European Satin Finish, the sinks blend in seamlessly with the overall aesthetics of your kitchen and come with a warranty of 10 years.



Advantages Stainless Steel Kitchen Sinks



Finish: All ARGENTO sinks come with a uniform European satin finish that aesthetically enhances the elegant design of the sink bowl.



Steel Thickness: All ARGENTO sinks are made of Stainless Steel grade 304 with a thickness of 1.2 mm. Grade 304 contains 18% Chrome and 8% Nickel which increases the resistance of the material to corrosion and rusting; providing extraordinary durability and unbeatable performance.



Coating: To avoid sound, the undercoat is extremely important for any stainless steel sink. All ARGENTO sinks are coated to about 0.5 – 0.8 mm thickness with Asphalt - a material which absorbs sound and protects the base of the sink from condensation and corrosion.



Sound Deadening Pad: In addition to the Asphalt coating, a special sound suppression pad of 2mm thickness is integrated into the ARGENTO sinks to absorb excessive noise of the Utensils during use.



Drain Pipe: The ARGENTO series come with a drain pipe which is specially designed to prevent clogging and ensure easy cleaning.



Easy to Clean: The inherent aseptic property of stainless steel makes the maintenance of ARGENTO sinks virtually effortless. They are hygienic and easy to clean.



10 Year Warranty: All ARGENTO sinks are guaranteed for 10 years against faulty workmanship and material. *T&C apply.



Extra Deep Bowl: ARGENTO sinks come with extra deep bowls ranging from 8 to 10 inches making it sufficiently easy to accommodate large and heavy-duty vessels for cleaning.



Topaz R 1818 - Single Bowl

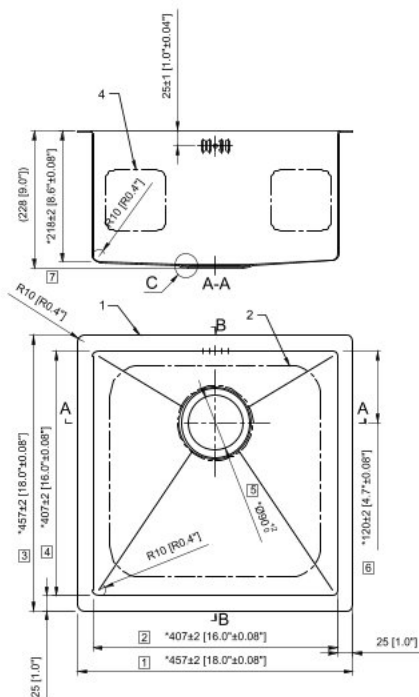

Topaz S2118- Single Bowl

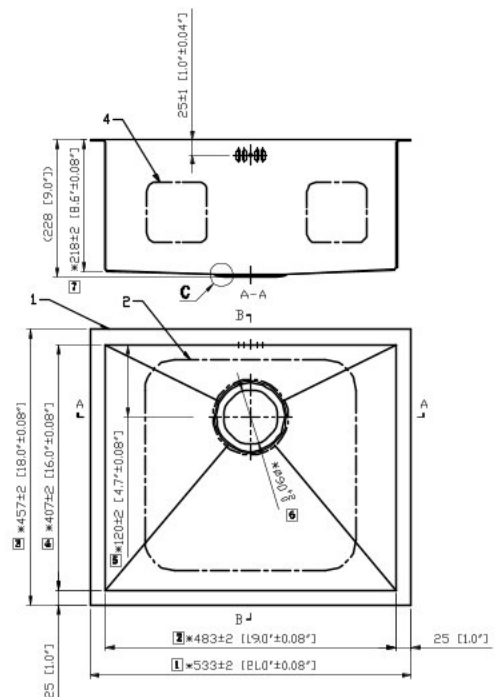

ORDERING INFORMATION

Product Description	Overall size (inch/mm)	Bowl Size (inch/mm)	Bowl Depth (inch/mm)	Article No.
1 Topaz R 1818 - Single Bowl	18 x 18 (457 x 457)	16 x 16 (407 x 407)	9 (228)	567.24.237
2 Topaz S2118- Single Bowl	21 x 18 (533 x 457)	19 x 16 (483 x 407)	9 (228)	567.24.257

Topaz R 2418D - Single Bowl



Topaz R 3118 - Single Bowl

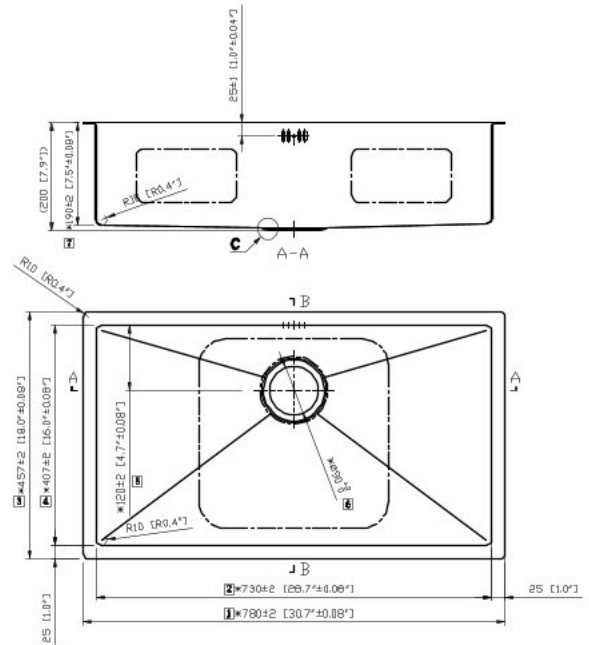
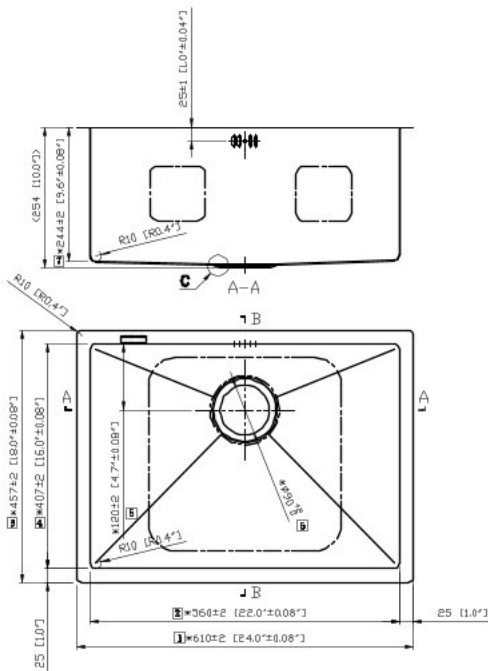

ORDERING INFORMATION

Product Description	Overall size (inch/mm)	Bowl Size (inch/mm)	Bowl Depth (inch/mm)	Article No.
1 Topaz R 2418D - Single Bowl	24 x 18 (610x457)	22 x 16 (560x407)	10 (254)	567.24.217
2 Topaz R 3118 - Single Bowl	31 x 18 (780x457)	29 x 16 (730x407)	8 (200)	567.24.207



Sapphire R4520 - Double Bowl



Sapphire R3618 - Double Bowl

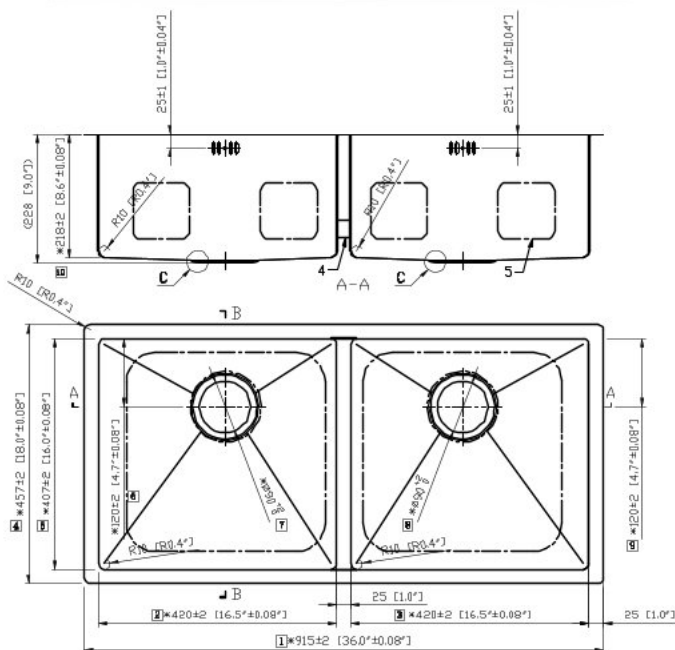
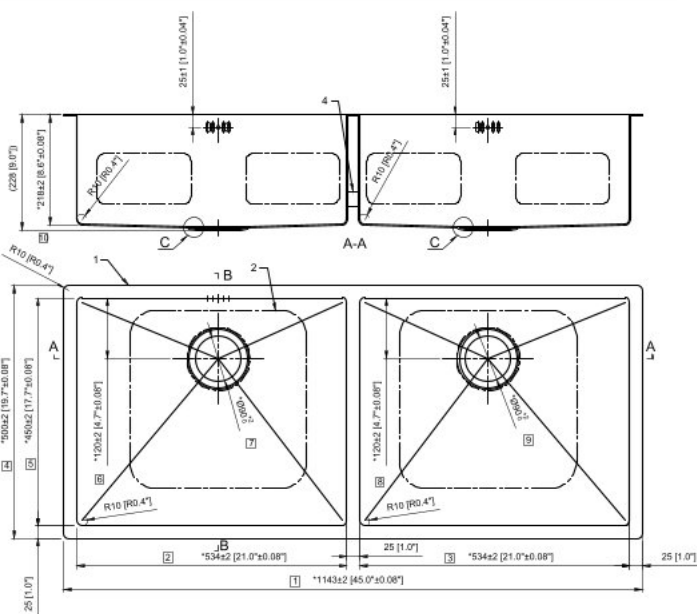

ORDERING INFORMATION

Product Description	Overall size (inch/mm)	Bowl Size (inch/mm)	Bowl Depth (inch/mm)	Article No.
1 Sapphire R4520 - Double Bowl	45 x 20 (1143 x 500)	21 x 18 (534 x 450)	9 (228)	567.24.297
2 Sapphire R3618 - Double Bowl	36 x 18 (914 x 457)	17 x 16 (420 x 407)	9 (228)	567.24.327

Ruby R4818- Double Bowl with Drainboard

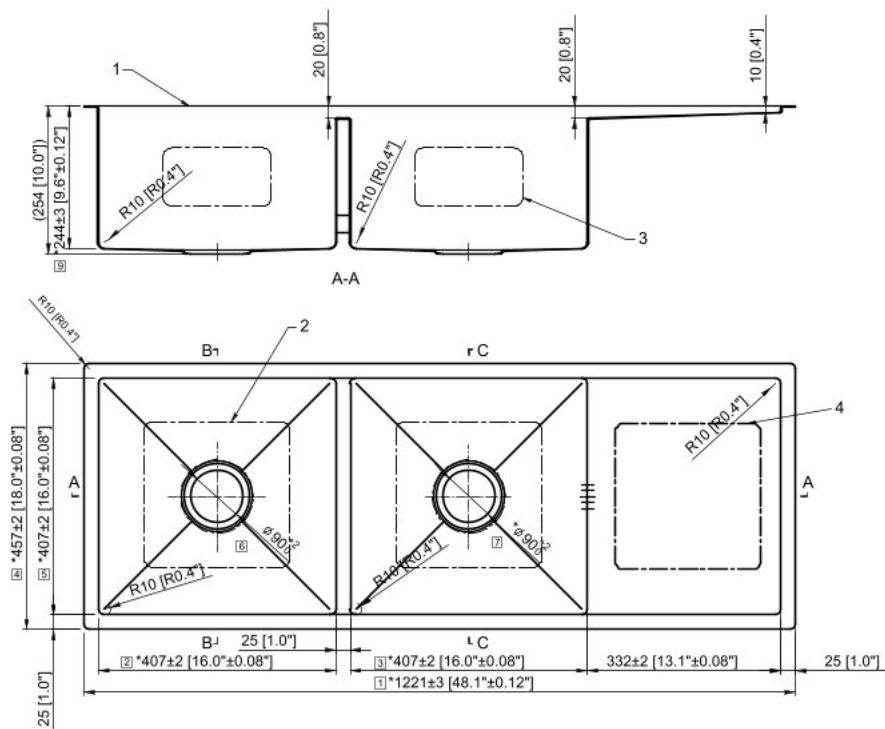

ORDERING INFORMATION

Product Description	Overall size (inch/mm)	Bowl Size (inch/mm)	Bowl Depth (inch/mm)	Article No.
1 Ruby R4818- Double Bowl with Drainboard	48 x 18 (1221 x 457)	16 x 16 (407 x 407)	10 (254)	567.24.287

Häfele SPLASH



The Splash Kitchen Sinks by Häfele are carefully engineered through a unique drawing process where pressure is individually controlled in combination with a lubrication process which draws out the sink bowls from a Grade 304 Stainless Steel sheet, without the steel itself breaking. The stainless steel sinks are then coated with an elegant satin finish to add a layer of protection against scratching or rusting. The grade 304 composition of Stainless Steel with 18% Chromium & 8% Nickel further enhances the durability of our sinks, making them highly tolerant to humid conditions.

Additionally, these sinks are tested to resist any external damages like chipping, cracking or peeling and the hygienic and aseptic properties of stainless steel make the maintenance virtually effortless! The well rounded shape of the Splash sinks also makes way for easy cleaning, eliminating the chances of any unwanted residues accumulating in the remote corners of the sink bowl.

With extra deep bowl depths, these sinks make the washing of heavy-duty vessels an effortless task. The Splash Range of Sinks comes with a special stone guard undercoating and rubber padding to absorb excessive noise levels of utensils during use. All sinks from the this series come with a 10 year warranty against faulty workmanship and material.

Features



Corrosion-Resistant: Häfele's range of SPLASH sinks are made up of 1mm Stainless Steel Grade 304 which makes them highly durable and resistant to corrosion



Contemporary Finish: These sinks come with a premium Satin Finish which not only exudes elegance but also provides scratch resistance.



Reduces Noise Levels: The Splash sinks are padded and Stone-Guard undercoated resulting in reduced noise levels when they are in use



Huge Capacity: Häfele's Range of SPLASH Sinks, with extra deep bowl depths, can easily accommodate heavy vessels during any cleaning cycle

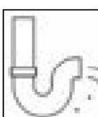

Versatile Drain System: The drain outlet is compatible with most garbage disposals available in the market. It comes with a stainless steel strainer and a plastic drainage pipe.



Comprehensive Packaging: These sinks come in an all-inclusive, easy-to-carry package equipped with mounting & installation brackets as well as cut-out templates



10 Year Warranty: Häfele offers a 10-years* warranty on its Splash range against faulty workmanship and manufacturing defect from the date of invoice.

T&C Apply

Astral Single Bowl 2118

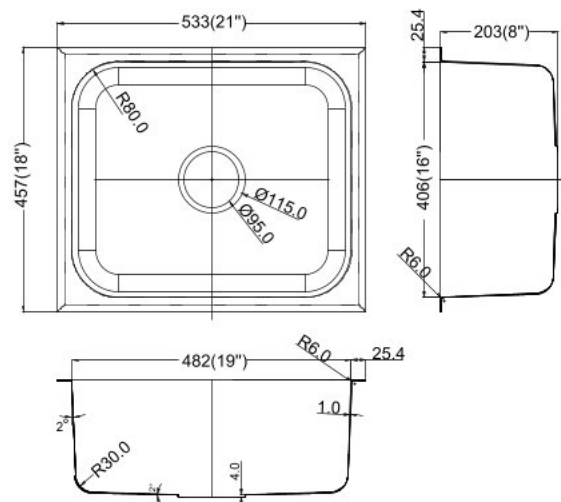

Optional Accessories:
 Drainkit - Astral Bottle Trap Kit SB - 577.00.901

ORDERING INFORMATION

Product Description	Overall size (mm/inch)	Bowl Size (mm/inch)	Depth (mm/inch)	Article No.
1 Astral Single Bowl 2118	533 x 457 / 21" x 18"	482 x 406 / 19" x 16"	203 / 8"	577.00.040

Astral Single Bowl 2418

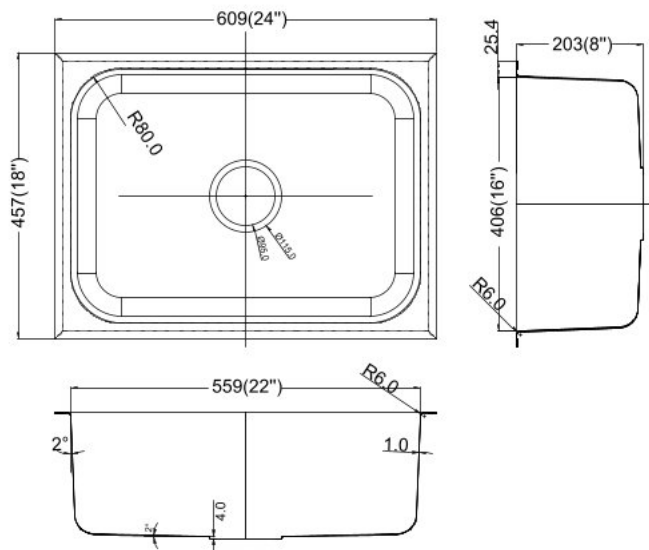

Optional Accessories:
 Drainkit - Astral Bottle Trap Kit SB - 577.00.901

ORDERING INFORMATION

Product Description	Overall size (mm/inch)	Bowl Size (mm/inch)	Depth (mm/inch)	Article No.
1 Astral Single Bowl 2418	609 x 457 / 24" x 18"	559 x 406 / 22" x 16"	203 / 8"	577.00.030

Astral Single Bowl with Drainboard 3620

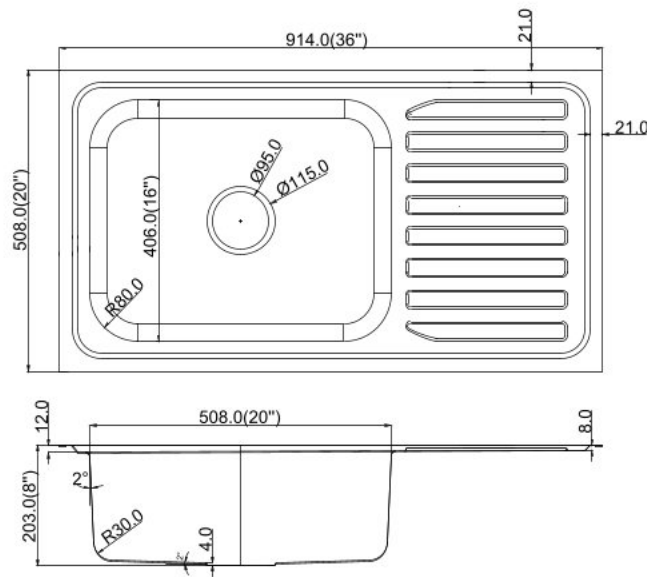

Optional Accessories:
 Drainkit - Astral Bottle Trap Kit SB - 577.00.901

ORDERING INFORMATION

Product Description	Over all size (mm/inch)	Bowl Size (mm/inch)	Depth (mm/inch)	Article No.
1 Astral Single Bowl with Drainboard 3620	914 x 508 / 36" x 20"	508 x 406 / 20" x 16"	203 / 8"	577.00.020

Orion Double Bowl With
Drainboard 4720

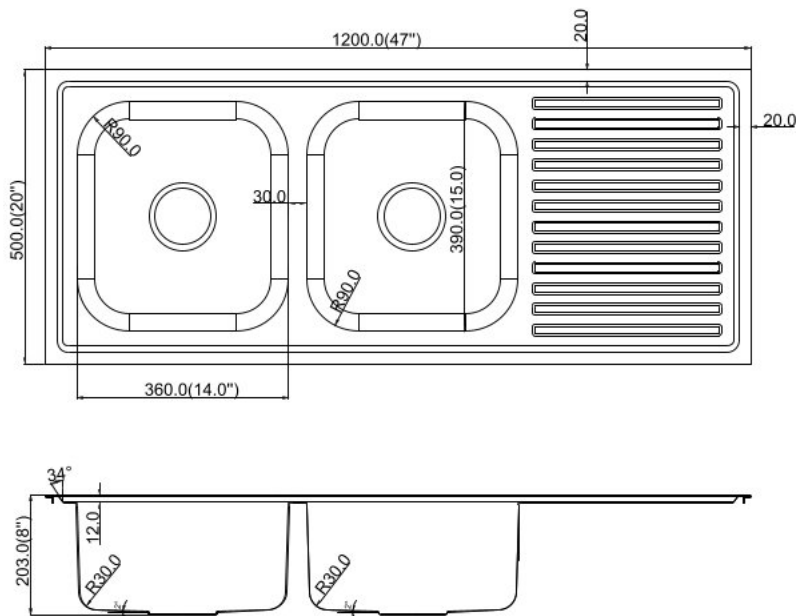
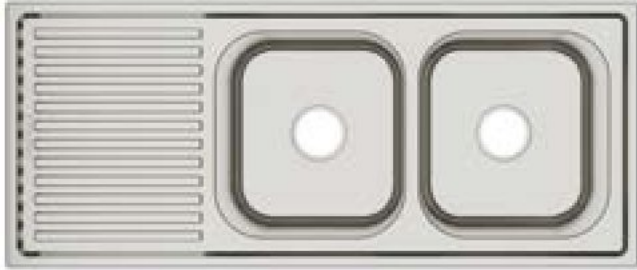

Optional Accessories:
Drainkit - Orion Bottle Trap Kit DB - 577.00.900

ORDERING INFORMATION

Product Description	Over all size (mm/inch)	Bowl Size (mm/inch)	Depth (mm/inch)	Article No.
1 Orion Double Bowl with Drainboard 4720	1200 x 500 / 47" x 20"	360 x 390 / 14" x 15"	203 / 8"	577.00.000

CAESARSTONE





Technical Data

CAESARSTONE ANATOMY



Miter Edge
Minimum Radius: W*

EDGE DETAILS:
Miter Edge

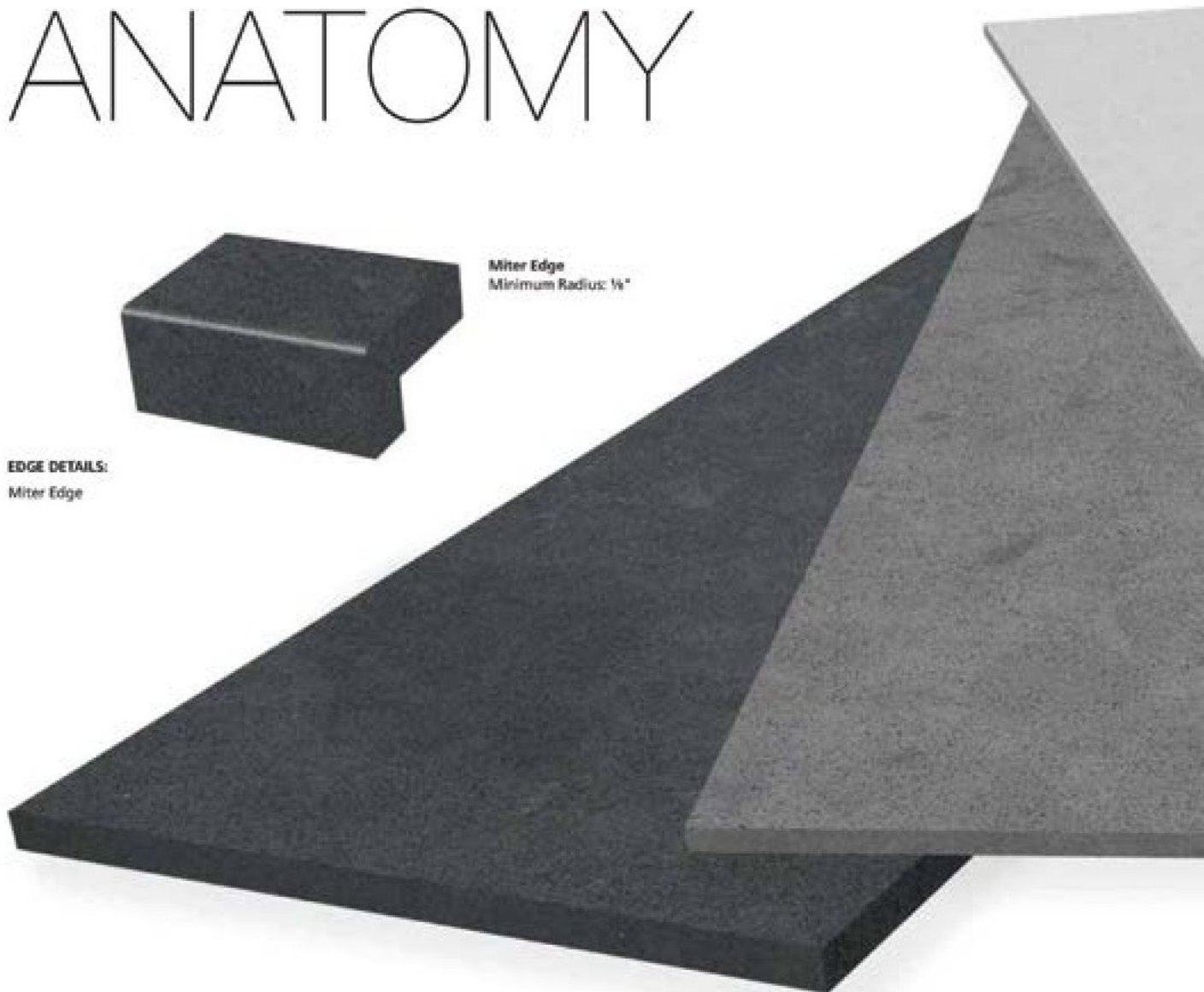

Quartz Pioneer

Since 1987, Caesarstone® has been creating quartz surfaces in their state-of-the-art manufacturing facilities utilizing the most advanced technologies available with the highest standards of quality control and environmental responsibility.

With three diverse collections - Classico™, Supernatural®, Motivo® in India - Caesarstone® is an ideal starting point whether you're building a new home or renovating your kitchen or bathroom.

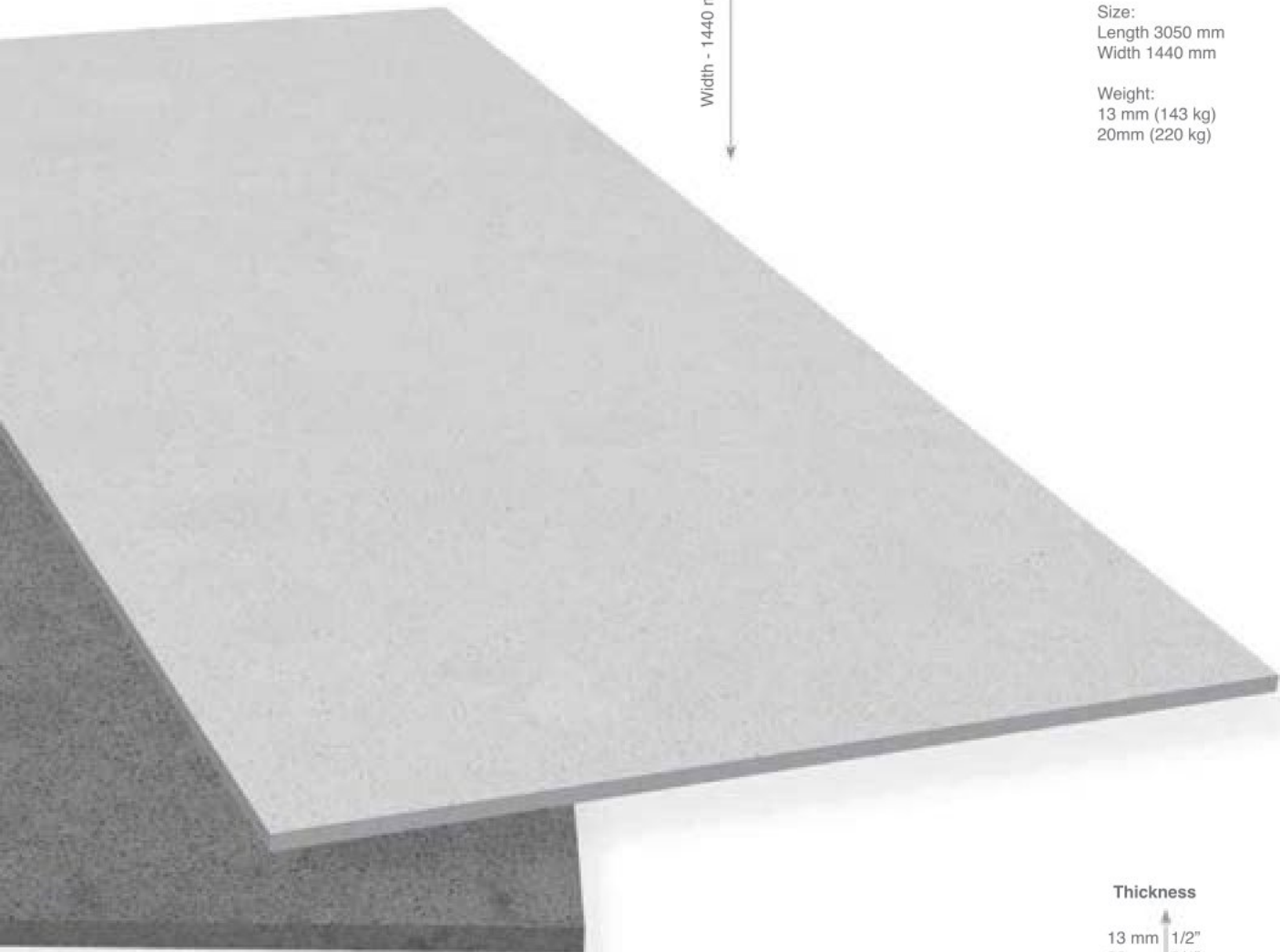

Technical Data

Length 3050 mm

Width - 1440 mm

1:36 Scale

Size:
Length 3050 mm
Width 1440 mm

Weight:
13 mm (143 kg)
20mm (220 kg)

Thickness

13 mm 1/2"
20 mm 3/4"

Classico™

Surfaces For Your Home

Caesarstone's Classico™ collection combines style and functionality with colours and designs ideal for numerous applications in both residential and commercial interiors such as kitchen benchtops, splashbacks, bathroom wall linings, custom made furniture and more.



1 Raven



2 Shitake



3 Organic White



4 Oyster



5 Frozen Terra

ORDERING INFORMATION

Product Description		Thickness (13mm)
1	Raven	562.00.006
2	Shitake	562.60.157
3	Organic White	562.60.177
4	Oyster	562.00.026
5	Frozen Terra	562.59.264



Supernatural™

The One of a Kind Collection

Just like an original work of art, every Supernatural slab is one of a kind a quartz surface that will take your interior décor to a whole new level. Mirroring nature's endless diversity and beauty, each slab is finished to perfection.

Inspired by some of the world's most beautiful natural marble, Caesarstone's supernatural designs represent the very best of what nature has to offer. Using cutting-edge technology, these earthy tones and delicate veins are infused with intricacies and textures never before seen on quartz surfaces.

The new Supernatural designs adorn any modern interior, while maintaining all the advantages and timeless qualities that make Caesarstone special.



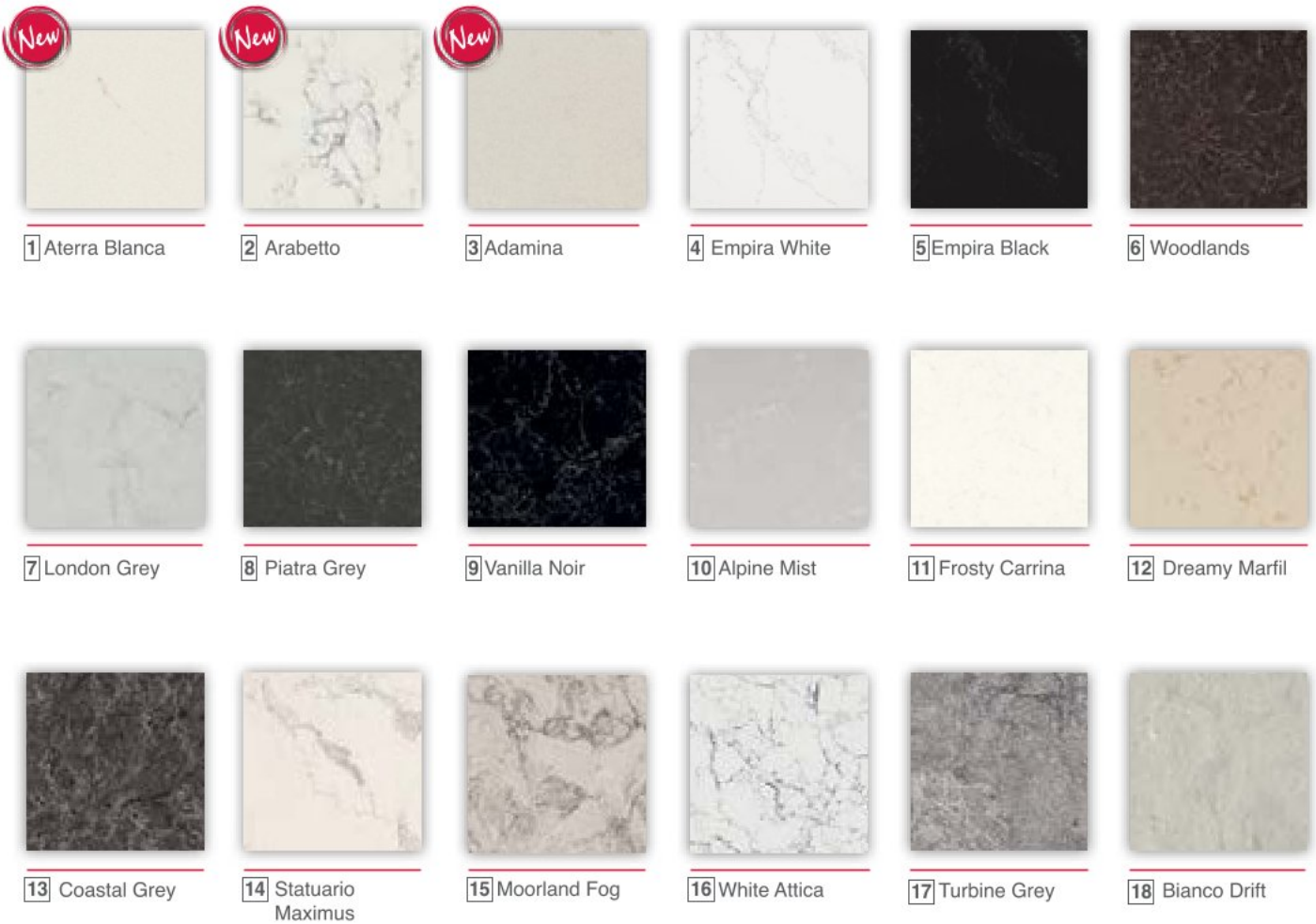

ORDERING INFORMATION

Product Description		Thickness	
		13mm	20 mm
1	Aterra Blanca (Jumbo)	-	562.59.991
2	Arabetto	-	562.59.565
3	Adamina (Jumbo)	-	562.59.580
4	Empira White (Jumbo)	-	562.59.371
5	Empira Black (Jumbo)	-	562.59.992
6	Woodlands	562.59.326	-
7	London Grey	562.60.625	-
8	Piatra Grey	562.60.197	-
9	Vanilla Noir	562.60.545	-
10	Alpine Mist	562.60.357	-
11	Frosty Carrina (Jumbo)	562.60.810	-
12	Dreamy Marfil (Jumbo)	-	562.60.100
13	Coastal Grey	562.60.727	-
14	Statuario Maximus (Jumbo)	562.59.806	-
15	Moorland Fog	562.59.016	-
16	White Attica (Jumbo)	562.59.801	-
17	Turbine Grey	562.59.056	-
18	Bianco Drift	562.60.377	-

Notes: Jumbo Size - 3340 x 1640 x 20mm

Metropolitan™



The Metropolitan Collection is a unique collection leading the urban interior trend. The Metropolitan Collection reflects the authentic textures of manufacturing, such as oxidized steel, poured plaster and raw concrete. These unpolished designs reveal variations in appearance and capture depth and movement throughout the surface. Caesarstone's new cutting-edge technology achieves a weathered patina in quartz never experienced before.



1 Black Tempal



2 Oxidian



3 Rugged Concrete



4 Cloudburst Concrete



5 Topus Concrete



6 Airy Concrete

ORDERING INFORMATION

Product Description	Thickness (20mm)
1 Black Tempal (Jumbo)	562.59.391
2 Oxidian (Jumbo)	562.59.411
3 Rugged Concrete (Jumbo)	562.59.002
4 Cloudburst Concrete (Jumbo)	562.59.081
5 Topus Concrete (Jumbo)	562.59.311
6 Airy Concrete (Jumbo)	562.59.301

Notes: Jumbo Size - 3340 x 1640 x 20mm

TERRA



Every story reflects a personal style, unique thought and creative imagination. Whether they are narrated through a novel, visualized through a movie or simply executed through a piece of design, stories need the right expression that can truly bring out their unique facets. In the world of design, stories are expressed through colours, textures, style and functionality. It is these aspects that make every design unique and individualistic. But, quite often, a designer finds it challenging to find such colours, textures and styles that can express the strong story behind a design.

Breaking all these limitations is Terra – the latest addition to Häfele's Range of Engineered Stone Surfaces under the Häfele Surfaces brand. This new in-house premium range of surfaces brings with it the tradition, knowledge and expertise that Häfele has in the space of Kitchens and Kitchen products. The Terra Range is Quartz dominated and is composed together with colour pigments and binding agents to form a solution that is immensely strong, versatile and creatively workable for a wide array of home applications.

While kitchen countertops takes a prominent spot in this list of applications, Terra also creates possibilities in Wall-cladding, Kitchen backsplashes and Bathroom countertops across the home. This surface can also find an ideal space in Office reception counters, Restaurant bar counters or even backsplashes and wall-claddings in Hotel lobbies and rooms.

Owing to its composition and colour consistency, Terra offers uniform and seamless design possibilities. It comes with 13 elegant yet contemporary colours that add to the versatility of this range. Each colour has a soul and unique characteristic, of its own.

THE TERRA EDGE

Terra – Häfele's in-house brand of premium surfaces – comes with a uniform and high colour consistency that runs throughout the surface owing to the patented Breton Technology. Terra surfaces are essentially made with quartz along with other compositions, giving it an eternal strength along with an innate flexibility to be designed to the tunes of your stories and imaginations.

Available in 20mm thickness, Terra surfaces are easy to fabricate and install in different interior applications. They are food-grade safe and extremely easy to clean, maintain and use. Owing to the inherent properties of quartz, Terra surfaces are non-porous as well as antibacterial, making them 100% safe, hygienic and long-lasting. They are also extremely immune to varying temperatures and do not decompose or change character when exposed to anything too hot or too cold.

With a host of stable and long-lasting advantages that Terra offers because of its inherent quartz properties, it can be a promising solution for a wide variety of applications ranging from kitchen countertops, kitchen backsplashes, bathroom counters and even wall cladding across the home interiors.



Dependable Quality: Terra surfaces are essentially made with quartz, a material that is known for its inherent strength and durability. Moreover, these surfaces are produced as per stringent quality standards and technical guidelines defined by Häfele. Terra surfaces are tested for their compressive strength and are certified to last. These virtues of strength, durability and consistent high quality make Terra the ideal surface for applications that have a high expectancy of long use.



High Colour Consistency: Terra surfaces come with a high colour consistency across the entire slab owing to the patented Breton Technology used in its production. This gives uniform design results, even in case of larger applications like long kitchen countertops. As opposed natural stone where each tile may look different from the other, Terra gives exceptional consistency and a seamless look that redefines the entire design or application that has been executed.



Stain And Acid Resistant: Terra Surfaces are highly resistant to any kind of staining or damage due to exposure to household chemical or acidic cleaning agents. This makes the entire length and breadth of the surface look the same for years, with no patchy decolorization, fading or stains.



Crack Resistant: Terra surfaces come with high flexural strength, protecting them from getting chipped or cracked in case a heavy object accidentally falls on the surface. Flexural Strength defines the resistance of material from any kind of breakage or damage when an external force is exerted on it.



Non-Porous & Anti-Bacterial: Owing to the inherent properties of Quartz, Terra surfaces are non-porous which means that cleaning and maintaining the surfaces is extremely easy. The non-porous material of these surfaces also ensures that no germs penetrate it, giving them anti-bacterial properties that provide for a safe and hygienic solution.



Scratch Resistant: In addition to being non-porous, Terra surfaces are also scratch-resistant, giving you one reason less to worry about high maintenance and fuss over these surfaces. So accidental drops of sharp objects on these surfaces will cause no visible scratches which are otherwise extremely tiresome to get rid of.



Temperature Resistant: Terra surfaces are heat resistant which means that they do not decompose or change character when exposed to high temperatures. The surfaces are also unaffected by cold temperatures; so you need not worry if you have left that bag of frozen peas or chicken to thaw on the surface.



Easy To Clean & Maintain: Owing to their resistance to stains or water, Terra surfaces are very easy to clean; just take a damp cloth with a mild cleaning agent and wipe it across the surface to get them as good as new. The tested high flexural strength and premium quality of Terra Surfaces make them extremely easy to maintain for long periods of time without any chips, cracks or breakages



Olympia Gold



Terra's Olympia Gold exudes sheer extravagance and luxury. The pure white base with brown and golden veins brings elegance to any interior design. It's rich finish elevates the exuberance of the interior space and lends a classy zing to it.

Nebula White

Acing the interplay of dark and white in a sophisticated and elegant design is Terra's Nebula White. A pure white base that reflects soft shadows of greyish veins, this shade is probably the most unique among the many reflections of Terra.



ORDERING INFORMATION

Product Description	Slab Dimension (LxWxT) mm	Finish	Article No.
1 Olympia Gold	3030 x 1430 x 20	Polished	564.42.083
2 Nebula White	3100 x 1520 x 20	Polished	562.57.083

Cemento

A cotton-white soft base with a detailed grey texture can best define Terra's Cemento. The beauty about this shade is that it changes its hue with the changing throw of natural light as the day goes by - a vibrant white in the morning sun and a calming grey as the night settles in.



Crema Dolce

The beige base and creamy veins of Terra's Crema Dolce will definitely remind you of the calming hues of twilight where light cloudy threads cut across a brownish sky. This shade breaks the monotony of white-toned interiors by adding a splash of elegant drama and hue.

ORDERING INFORMATION

Product Description	Slab Dimension (LxWxT) mm	Finish	Article No.
1 Cemento	3030 x 1430 x 20	Polished	564.42.073
2 Crema Dolce	3100 x 1520 x 20	Polished	562.57.043

Carbonite



The dark matt finish of Terra's Carbonite lends an elegant Industrial look to any interior space. When you want rugged interiors that blend the light shades with the dark impeccably, Terra's Carbonite can be your perfect choice.

Stonica

Another shade that's inspired by nature is Terra's Stonica. Its light grey shade with minute grains and smooth texture will remind you of the cool shimmering sand at a beach. A perfect choice for earthy interiors!



ORDERING INFORMATION

Product Description	Slab Dimension (LxWxT) mm	Finish	Article No.
1 Carbonite	3030 x 1430 x 20	Polished	564.42.063
2 Stonica	3030 x 1430 x 20	Polished	564.42.053

Eggnog

Pastels are yet another favourite among designers and have been in the race for years at stretch. They impart character to any interior space and truly individualize it to a specific style. Terra's Eggnog is a creamy pastel shade interspersed with blending white veins that has the potential of becoming a top favourite among designers who are looking for something original yet different.



Himalayan White

“Less is more” – a trend that is redefining home interiors with minimalistic design, clean straight lines and a seamless flow of uniform tonality. Terra's Alba White encompasses all these traits of minimalism with its fresh, pristine white colour that runs uniformly across the surface. A great companion to modern contemporary kitchens and other areas of the home, fetching for a simplistic design that never goes out of fashion.

ORDERING INFORMATION

Product Description	Slab Dimension (LxWxT) mm	Finish	Article No.
1 Eggnog	3030 x 1430 x 20	Polished	564.42.013
2 Himalayan White	3300 x 1650 x 20	Polished	562.57.064

Alba White



“Less is more” – a trend that is redefining home interiors with minimalistic design, clean straight lines and a seamless flow of uniform tonality. Terra’s Alba White encompasses all these traits of minimalism with its fresh, pristine white colour that runs uniformly across the surface. A great companion to modern contemporary kitchens and other areas of the home, fetching for a simplistic design that never goes out of fashion.

Cinder Grey

The ultimate surface shade that complements the latest trend of dark earthy hues in home interiors is Terra’s Cinder Grey. With a Dark Grey base shade and a generous spread of Light Grey granules that provide an even texture, this elegant surface can also beautifully contrast lighter designs for those who want to keep it traditional.



ORDERING INFORMATION

Product Description	Slab Dimension (LxWxT) mm	Finish	Article No.
1 Alba White	3100 x 1520 x 20	Polished	562.57.053
2 Cinder Grey	3030 x 1430 x 20	Polished	564.42.043

Gris Royale

An absolute companion to woody interiors, Terra's Gris Royale adds subtlety and minimalism to any given space. A light grey base with dark veins that cut across the length of the surface, make this shade relatable and real.



Moon White

This calming shade of white with a detailed spread of fine grains forms an immediate connect with the therapeutic moonlight that beautifully contrasts the night. Terra's Moon White imparts poise and enamour to any environment that it is applied to. It can accentuate the look of light tones or even beautifully contrast darker tones of any interior room or area.

Vena Oro

Copper and Rose Gold are trending colours in home interiors and are definitely being experimented with in Kitchens, Living rooms and even Bedrooms. Bringing a subtle whiff of copper and gold as intricate veins running on a virgin white back-shade is what defines Terra's Vena Oro, making it a truly unique, stylish and trendy surface to apply to any home setting.



ORDERING INFORMATION

Product Description	Slab Dimension (LxWxT) mm	Finish	Article No.
1 Gris Royale	3100 x 1520 x 20	Polished	562.57.023
2 Moon White	3100 x 1520 x 20	Polished	562.57.073
3 Vena Oro	3030 x 1430 x 20	Polished	564.42.023

DEKTON







Dekton Kira



Dekton Trilium

WHAT IS DEKTON ?

DEKTON is a new and unique surface created through the innovative combination of 28 natural minerals found in nature and its exclusive ULTRA COMPACTING TECHNOLOGY.

This technology replicates and enhances the metamorphic changes that natural stone undergoes over a millennia through exposure to high pressure and high temperature.

This evolution represents a technological and industrial leap capable of generating a revolutionary material and leading product with virtually ZERO porosity and non-existence of any micro flaws that cause weakness.

Dimensions

The DEKTON® slab has a nominal dimension of 3200 x 1440 mm. Depending on the type of colour and formula used to manufacture DEKTON®, the useful surface area may be larger than the above dimensions. In the event of a defect appearing, the surface area of the slab

decreases in sufficient measure to allow the defect to be eliminated from what is considered the useful surface area. In other words, the area affected by the defect is subtracted, as shown in the example. The DEKTON® slabs are marketed in three different thicknesses: 8, 12 and 20 mm.

The maximum deviation from the nominal value is $\pm 2\%$. As an example, for a 20 mm thick slab, the maximum variation that the slab may have is ± 0.4 mm.



Textures / Finishes

The DEKTON® colours may have different textures such as Smooth matte, Textured matte (wood, slate / limestone) and Polished. Dekton Grip, our finish for wet zones, is also available.

The texture is determined by the name of the colour. Not all the textures are available in all the colours.

COLLECTION	TEXTURE	COLOURS
SOLID	Smooth matte	DOMOOS, ZENITH
	Textured matte	SIRIUS
NATURAL	Smooth matte	AURA 22, ENTZO, KAIROS, DANAE, KELYA, SIROCCO, KIRA, LAURENT, PORTUM, ETER, AERIS, SASEA, REM
	Textured matte	BROMO
TECH	Smooth matte	KERANIUM, KEON
INDUSTRIAL	Smooth matte	TRILIUM, LAOS, SOKE
LIQUID	Smooth matte	SHELL, SKY



Laurent



Soke



Laos

DEKTON FORMATS

**High UV Resistance**

Dekton is highly resistant to ultra violet (UV) light and will not fade or degrade over time making it perfect for both indoor and outdoor applications.

**Highly Scratch – resistant**

Dekton is the most scratch resistant surface on the market and while the slip of a knife won't damage Dekton, cutting boards are still recommended to protect your household utensils.

**Resistant to stains**

While other surfaces are stain resistant Dekton is completely stain proof. Even the most stubborn stains like wine, coffee, markers and rust can easily be removed from the surface. Since Dekton has extremely low porosity and contains no resins, it is chemically resistant to drips or splashes of common household chemicals like bleach and drain cleaners. Even oven degreasers won't harm Dekton.

**High resistance to fire and heat**

Dekton withstands high temperatures without burning, scorching or cracking. Hot pots and appliances like crock pots can be placed directly on the surface with no worry of damage.

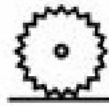
**Resistant to abrasion**

Dekton is even more resistant to abrasion than granite making it the ideal surface for commercial applications and high traffic areas such as flooring. While other surfaces show wear overtime, Dekton finish will last for the life of the product and will never need to be re-surfaced or re-finished.

**Resistant to ice & thawing**

Dekton's low coefficient of thermal expansion makes it thermal shock proof from both extreme heat and extreme cold. It's natural resistance to ice and thawing makes it perfect to use in even the coldest environments.

**High mechanical resistance**

With over 5 times the flexural strength of granite, Dekton can be installed in thinner material over greater spans allowing for up to a 12 inch unsupported overhang on worktops, islands and bar tops. Dekton's high compressive strength makes it an ideal material for walkways, pavers or driveways.

**Non – porous**

Dekton is non porous and never needs to be sealed. It naturally prevents liquids and gases from penetrating the surface making it a low maintenance surface that is easier to clean.

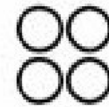
**Colour stability**

The manufacturing process used to make Dekton allows us to control the pigmentation and decoration of the material giving better colour consistency from slab to slab and resulting in a long lasting product that will not fade overtime. The surface you install today will maintain the same new appearance for the life of the product.

**Dimensional stability**

Dekton is very consistent in both dimension and thickness throughout the slab which minimizes the need for field corrections and allows for easy installation.

**Waterproof**

Dekton is highly water resistant.

Wall Cladding



Gone are the days when your kitchen and dado walls hide behind plastered paints, inconsistent tiles or dull wall papers. Dekton's unique surface properties like low water absorption and fire resistance make it an ideal choice for wall cladding applications in kitchens as well as the other areas of your interior spaces. Moreover the dimensional stability provides an overall consistency in design making for a seamless look without borders or differences. The end result is a surface that adorns your walls with spectacular aesthetics as well as robust and ever-lasting durability

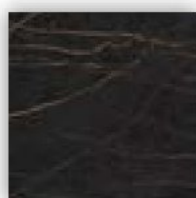

1 Laurent



2 Bromo

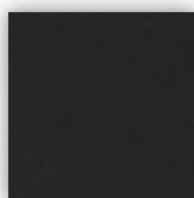

3 Domoos



4 Sirocco



5 Danae

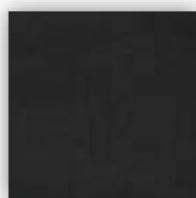

6 Sirius

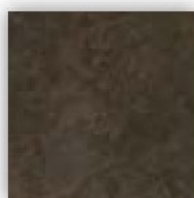

7 Keranium



8 Keon

ORDERING INFORMATION

Product Description		Size (mm)	Article No.
1	Laurent	3200 x 1440 x 4	562.58.411
		3200 x 1440 x 8	562.58.416
		3200 x 1440 x 12	562.58.418
2	Bromo	3200 x 1440 x 8	562.58.496
3	Domoos	3200 x 1440 x 8	562.58.006
4	Sirocco	3200 x 1440 x 4	562.58.581
		3200 x 1440 x 8	562.58.016
		3200 x 1440 x 12	562.58.588
5	Danae	3200 x 1440 x 8	562.58.156
6	Sirius	3200 x 1440 x 4	562.58.301
		3200 x 1440 x 8	562.58.306
		3200 x 1440 x 12	562.58.308
7	Keranium	3200 x 1440 x 8	562.58.046
8	Keon	3200 x 1440 x 8	562.58.106

Flooring and Indoor Countertops

The aesthetic appeal of any kitchen is greatly emphasized by the choice of countertops and flooring materials used. Today, the need to move away from clinical and functional designs is changing the spectrum of material choices available in the market. Dekton, with its unique material properties, forms an ideal choice for every surface in your kitchen – be it countertops, flooring or even cabinet fronts. It's scratch and stain resistance properties along with low water absorption levels make it a robust choice for countertops and floorings. The spectrum of designs and patterns available through Dekton, bring with it the flexibility to design your kitchen your way – you may choose to follow a seamless synergy between the flooring, cabinets and countertops or else bring in a healthy contrast of tones.



1 Laos



2 Portum



3 Trilium

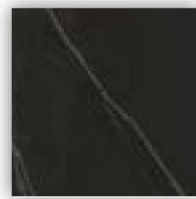

4 Kelya



5 Zenith



6 Kira



7 Kairos

ORDERING INFORMATION

Product Description		Size (mm)	Article No.
1	Laos	3200 x 1440 x 4	562.58.571
		3200 x 1440 x 8	562.58.516
		3200 x 1440 x 12	562.58.578
2	Portum	3200 x 1440 x 8	562.58.526
3	Trilium	3200 x 1440 x 8	562.58.196
		3200 x 1440 x 12	562.58.198
4	Kelya	3200 x 1400 x 4	562.58.061
		3200 x 1440 x 8	562.58.066
		3200 x 1400 x 12	562.58.068
5	Zenith	3170 x 1420 x 8	562.58.116
6	Kira	3200 x 1440 x 8	562.58.446
		3200 x 1440 x 12	562.58.448
7	Kairos	3170 x 1420 x 8	562.58.136

Note: Recommended thickness for countertops is 12mm

Outdoor Countertops



When designing an outdoor surface we need to take gravity into account: everything floating in the air will end up falling onto it. And it can be unused for weeks and months. A strong material with high resistance to UV-rays, thermal fluctuations, Scratches and stains would be your best bet in such applications. Sounds hypothetical? Not really. Dekton surfaces come with the ideal properties to sustain the harsh conditions of outdoor applications and thus become your ideal choice for countertops that need to be installed outside your home. The myriad choice of finishes and designs available in this range can help you create a unique application, just the kinds you had always imagined.



1 Soke



2 Entzo



3 Aura 22

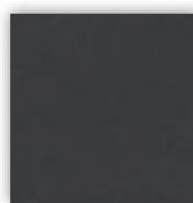

4 Eter



5 Aeris



6 Sasea



7 Liquid Shell



8 Rem



9 Liquid Sky

ORDERING INFORMATION

Product Description		Size (mm)	Article No.
1	Soke	3200 x 1440 x 8	562.58.486
		3200 x 1440 x 12	562.58.488
2	Entzo	3170 x 1420 x 8	562.58.146
3	Aura 22	3200 x 1440 x 4	562.58.671
		3200 x 1440 x 8	562.58.676
		3200 x 1440 x 12	562.58.678
4	Eter	3200 x 1440 x 4	562.58.591
		3200 x 1440 x 12	562.58.598
5	Aeris	3200 x 1440 x 8	562.58.606
6	Sasea	3200 x 1440 x 4	562.58.610
		3200 x 1440 x 8	562.58.617
7	Liquid Shell	3200 x 1440 x 8	562.58.627
8	Rem	3200 x 1440 x 8	562.58.637
9	Liquid Sky	3200 x 1440 x 8	562.58.647

Note: Recommended thickness for countertops is 12mm